

# ***ALUMINUM & COPPER ALLOYS PRESSURE DIE CASTING***

*Designing & supplying technical solutions*





# ***Our Company***



# About Us ...

- Corporate name : **FAVI S.A.**
- Address:  
14 rue Louis Deneux  
80490 Hallencourt – France
- Authorized capital : 960.000€
- DUNS Nr. : 278975602
- 400 employees
- 3 shifts/day & 5 days/week
- 4.000 tons of alloys per year



## Contact names

Function	Name	Phone	Mail
General Manager	Eric Rousseaux	+33 (0)3.22.28.20.50.	erousseaux@favi.com
Managing Director	Dominique Verlant	+33 (0)3.22.28.20.67.	dverlant@favi.com

# FAVI in Hallencourt



- 2 Plants
  - 23. 000 m<sup>2</sup> (mainly dedicated to the automotive market)
  - 4.500 m<sup>2</sup> (for 'non-automotive' parts)

# Our History – Some Key Dates

**1957** : Founding of FAVI S.A. / Manufacture of sanitary products.

**1971** : Take-over of FAVI S.A. by AFICA, the leading copper alloys refiner in Europe.

**1978** : Normalisation of our main alloys including the

**1979** : 1st series delivery of gearbox forks.

**1999** : 100 million gearbox forks delivered.

**2002** : Start of production copper rotors.

**2006** : 200 million gearbox forks delivered.

**2011** : 1,000,000 copper rotors delivered.

**2014** : Start of gearbox forks production in aluminium



# Our Management

FAVI developed in the 80's a CUSTOMER focused organization where the structure fades to assure full listening of the autonomous and responsible teams.

An unusual management that promotes a constant search for customer love, trust

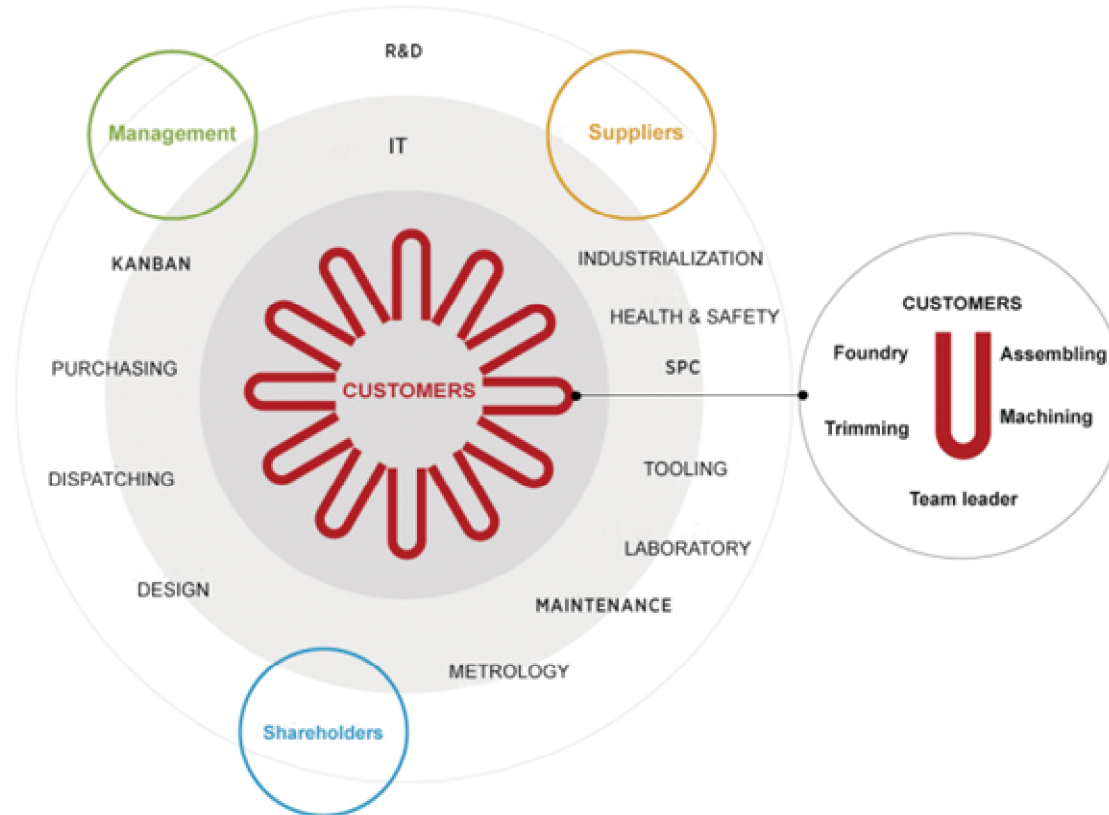

# Turnover 2015 (k€)

Year	Turnover France	Turnover Export	Total	% Export
2015	39 M€	32 M€	71 M€	45%

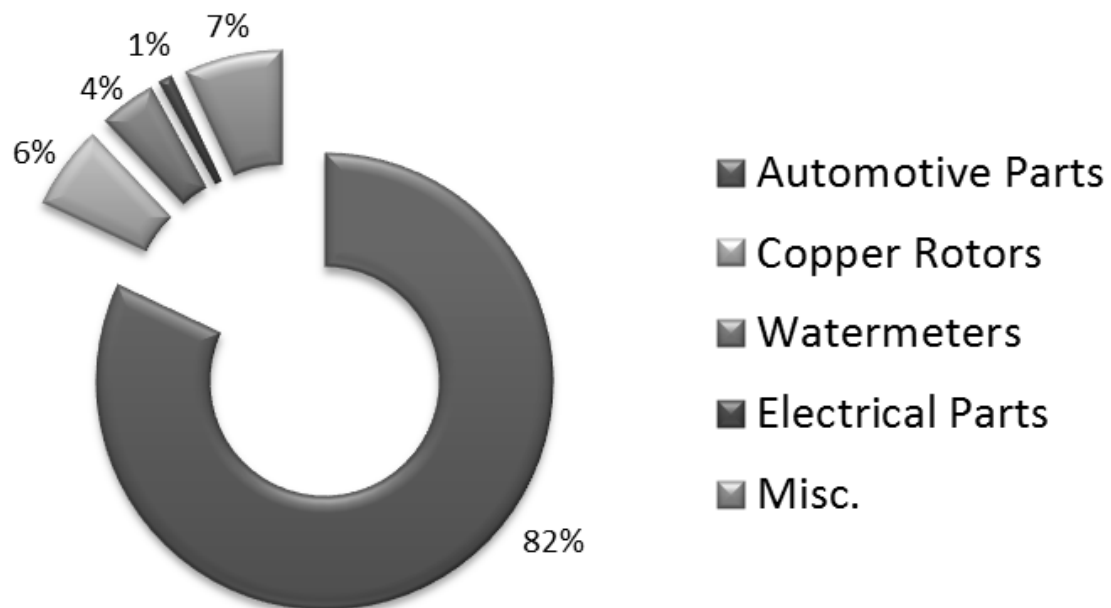

# Export Areas



FAVI is shipping parts to 14 countries for a turnover of 32 M€ (2014).

# They Trust & Award Us

- **PSA :**

- Quality Award 2010.
- QSB + Certification 2014.
- Best Plant 2014.
- Best Plant 2015.

PSA PEUGEOT CITROËN



- **MIDEST :**

- Innovation Award 2012.

- **TECHNOFAN:**

- Innovation Award 2015 (Copper Rotors).



# Q.S.E. Management and Sustainable Development

The achievement of 0 accident, 0 pollution, 0 delay, 0 break-down, 0 mistake is the result of a dynamic and systematic approach that made FAVI what it is today:

- 1st European Foundry to be certified « **ISO 14.001** » in 1997.
- 1st French Company to be certified « **OHSAS 18.001** » in 2000.
- 1st French Company with a certified « **Unified Management Q.S.E** » in 2002.
- 1st European Foundry to be certified « **ILO OSH 2001** » in 2008.
- FAVI is also certified « **ISO 50.001** » in 2015.





# ***Our Industrial Know-How***



# Research & Development

FAVI has always considered R&D as its priority. This is our largest department, which is composed of 31 engineers & technicians.

Typical projects are :

- Researching and developing specific alloys.
- Developing innovative technologies in product processing.
- Developing and optimizing products and industrial processes.



# Concept and Product Design

- **CAD**
  - Pro Engineer Version Creo 3
  - Solidworks 2015
  - Catia V5
- **Finite Elements Analysis**
  - Ansys v.16
- **Rheology**
  - Novacast last version
- **Rapid Prototyping in 3D**
- **OFTP Links**
  - Ft Master



# Product validation

Our test laboratory validates products and materials :

- Through material structural analysis and metallurgical testing.
- Through static, dynamic & fatigue testing to validate product function and resistance.
- Through specific bench testing on request :
  - Synchro, gearbox & motor test benches have been developed for specific applications.
  - FAVI has been recognized in July 2015 as being able to carry out tests and provide



# Industrial Resources

We internally design & manufacture:

- Foundry & Cutting Tools (Tools maintenance is also made in-house).
- Machining & Assembly machines.
- Control Devices.

This is a real advantage to industrialize your products offering you continuous improvement throughout the manufacturing process.



# Production Means



- 18 pressure die casting machines (80 à 900 tons)
- 23 furnaces for different alloys
- 11 clipping presses (20 to 100 tons)
- Specific control means (Radioscopy, Spectrometry, Leak Test, Material Hardness, Geometrical Control ...)
- Surface treatment workshop
- 3 high capacity transfer machines
- 80 specific transfer machines
- CNC lathes and milling machines



# ***Our Alloys***

# ***Our Products***



# Our Alloys

Alloy	Rm N/mm <sup>2</sup>	Rp 0,2% N/mm <sup>2</sup>	A%	Hardnes s HRB	Applications / Characteristics
Al Si9 Cu3 (Fe) (Zn)	240	140	< 1	80	Aluminium alloy for automotive applications.
Al Si15 Cu3 Mg	277	262	< 1	70	A light, hard wearing aluminium alloy for automotive applications.
Cu Zn27 Mn3 Al2	488	372	4.7	83	A hard wearing resistant brass alloy.
Cu Zn25 Al5 Mn4 Fe3	695	625	2.4	101	A brass alloy, with low lead content giving high handi

... Other alloys available on demand !

**FAVI is able to develop new alloys to satisfy your needs !**



**AB+®**  
Anti microbial brass



**Cu Zn40 Pb0,2**  
A brass alloy with low lead content, for 'drinking water' applications, compliant with the american AWWA standards.

# SCARF FORKS & ASSEMBLIES, IN MASS OF aluminium

More than 300 million forks delivered up to  
now.

**FAVI is the European Leader on this  
market.**



## Main Customers



Volkswagen



OPEL



Audi



FIAT CHRYSLER AUTOMOBILES



GETRAG

PSA PEUGEOT CITROEN

# Automotive components



**Braking System**



**Water Pump Turbines**

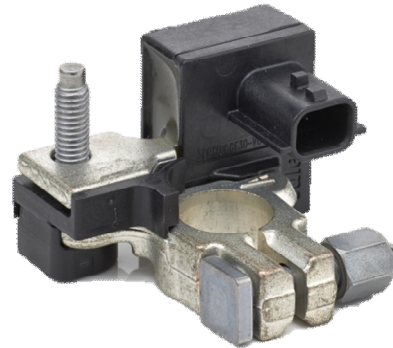

**Battery Terminals**



**Control Levers**

## Main Customers





# Die cast copper rotors

- **Innovation Process :**
  - Replacing aluminum by copper in the rotors for asynchronous motors.
- **Advantages :**
  - Efficiency ↗
  - Motor size ↘
  - Torque ↗
  - Working temperature ↘
  - Lifetime (x2) ↗
- **Size & Weight Limits :**
  - 21 kg copper per rotor
  - 400 mm diameter
  - 450 mm length



# Die cast copper rotors

- **Applications :**

- Motors for high speed machining machines
- High efficiency motors
- Traction motors for EV
- Electrical power steering
- Compressors
- Alternators
- Pumps
- Fans

**2 million copper rotors delivered up to now.**



## Main customers



# Size and weight limits :



**21 kg or 46.3lb Copper per rotor  
400 mm or 15.75" Diameter  
450 mm or 17.72" Length**

# FAVI: a reliable production

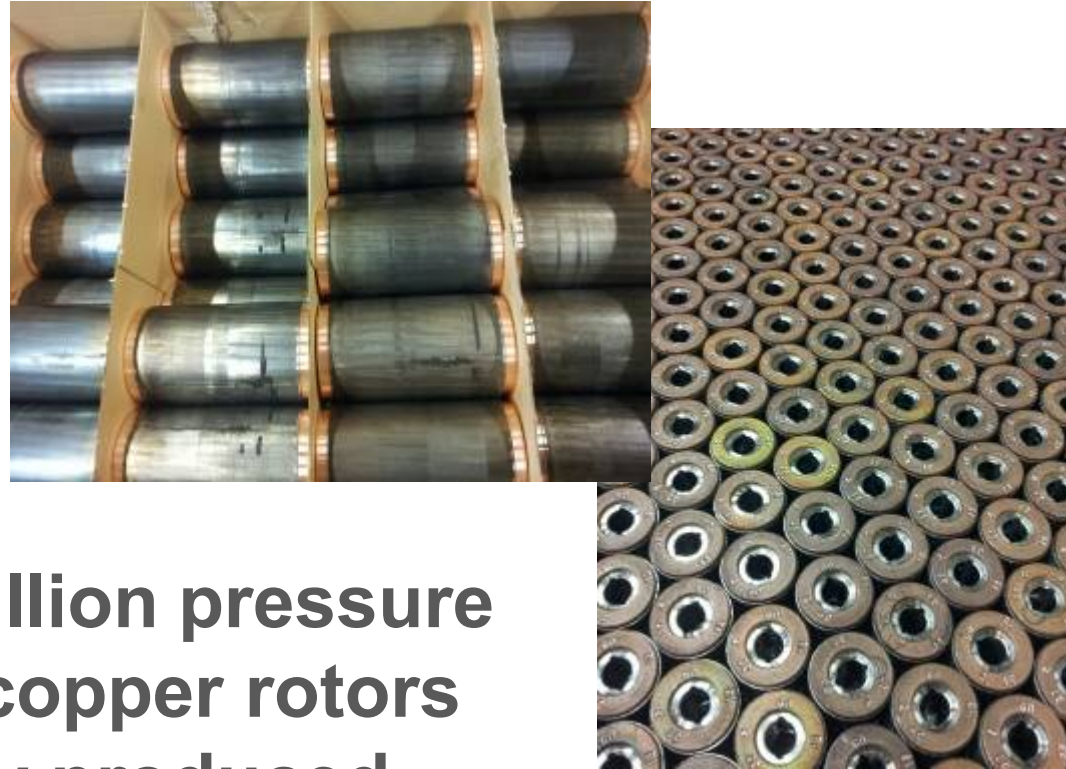

**Over 2 million pressure diecast copper rotors already produced**

# Mechanical properties of pressure die-cast copper



HPDC copper samples	Rp (MPa)	Rm (MPa)
Max	75	201
<b>Mini</b>	<b>55</b>	<b>115</b>

*According to the literature, the properties of cast copper (gravity) are as follows :*

- *Rm : 150 MPa*
- *Rp 0.2 : 40 MPa*

# R o t o r s

Replacing Aluminum by copper in the rotors for induction motors allows:



Efficiency

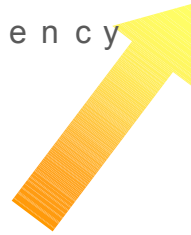

Torque

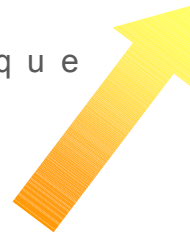

Lifetime (x2)

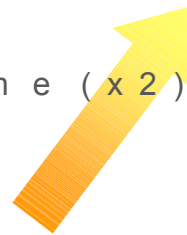

Motor size

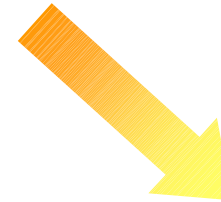

Working temperature

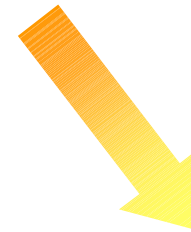

# Conductivity of HPDC copper

- **Conductivity of the pressure die cast copper:**

**97 ±3 %IACS**

Désignation pièce : Rotor 30/105 Lg140

Client :

Norme :SPC Reference manual second printing march 1995.

Date de prélèvements : 2007 à 2011

Date d'émission: 22 Juin 2011

Référence client :

Favi : 23271

Description de la variable	Échantillons	Caract spécifique	Limite de spécification inférieure	Limite de spécification Cible	Moyenne	Écart-type	Pp	Ppk
Pourcentage IACS ( 2007 )	60		94%	100%	99,596	0,38		4,904
Pourcentage IACS ( 2008 )	60		94%	100%	99,371	0,327		5,461
Pourcentage IACS ( 2009 )	120		94%	100%	99,358	0,539		3,312
Pourcentage IACS ( 2010 )	120		94%	100%	99,504	0,363		5,043

# High rotating speed test

- Test made on a rotor diameter 103mm

Rotor tested up to 23 500 rpm.

A rotor diameter 200mm is used for running test benches at a rotating speed of 12 000 rpm

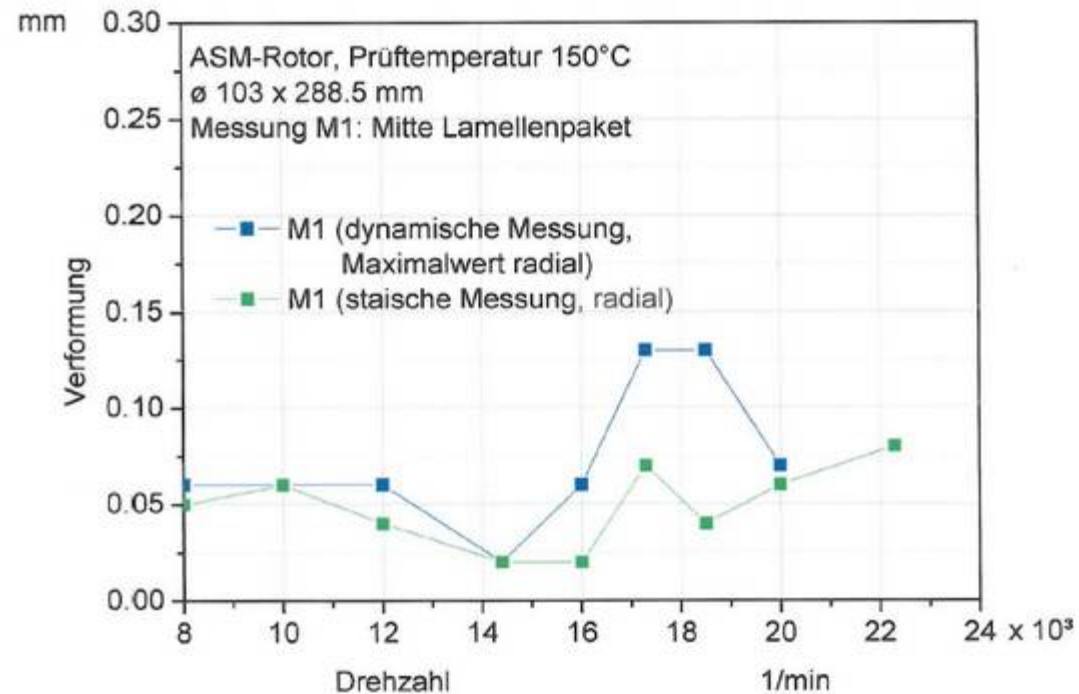

Radiale Vermessung in der Mitte des ASM Rotors (M1) in Abhängigkeit von der Prüfdrehzahl bei 150°C (+/- 20 °C) Prüftemperatur

# Comparison Cu vs Al rotor for a 4kW industrial motor

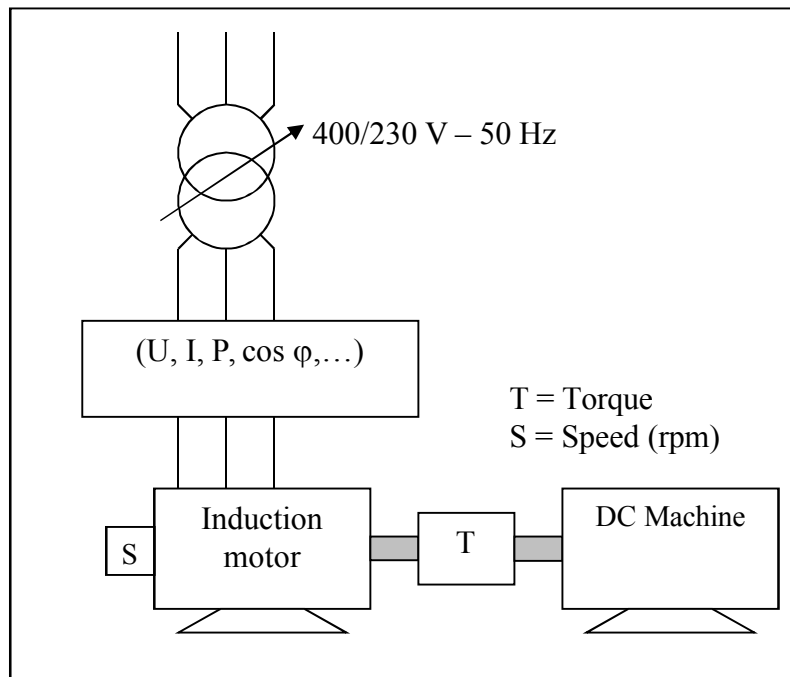

# Efficiency / Output power for a 4 kW induction motor:

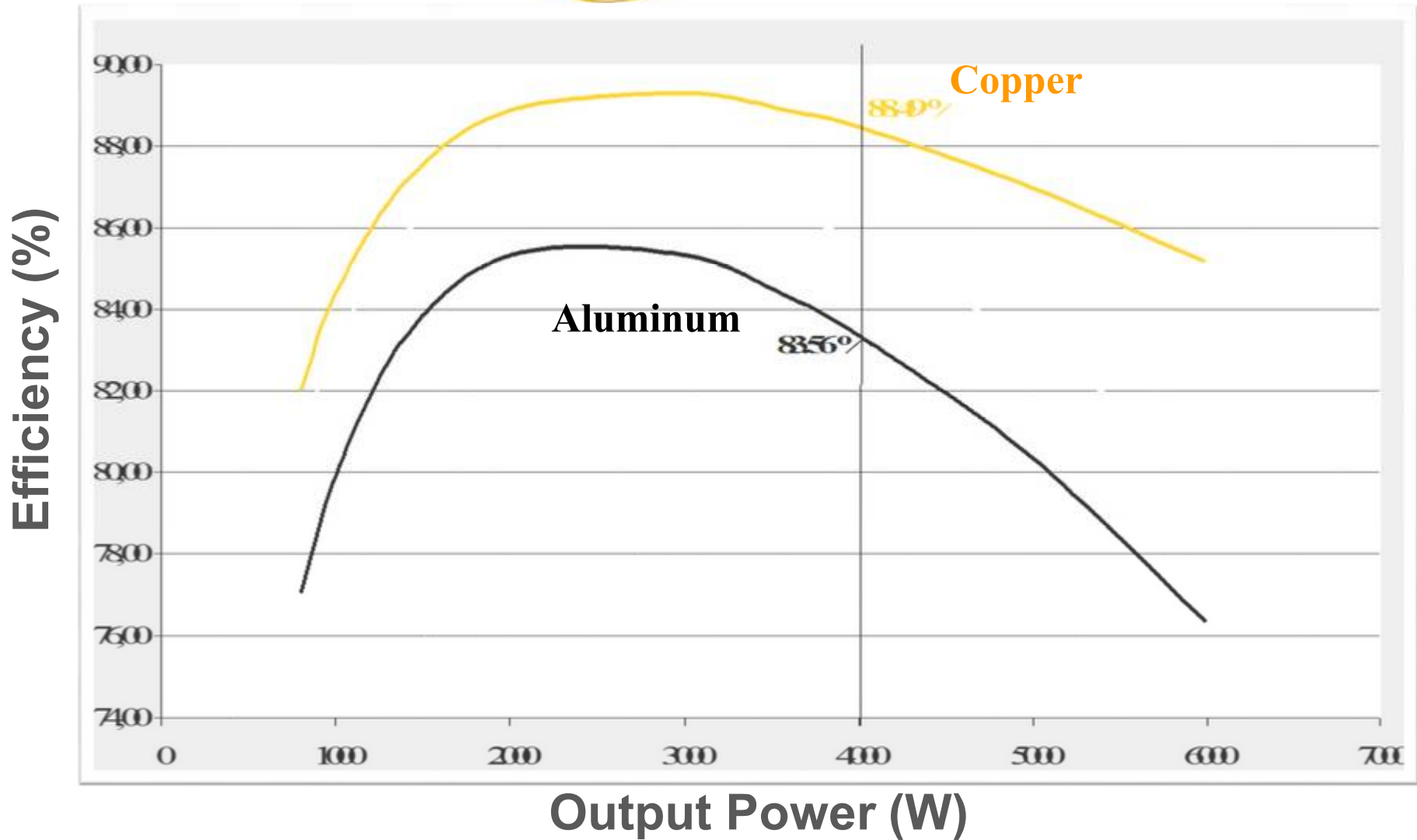

# Losses splitting acc.to Standard IEC/CEI 54-2:1972

	Joules- losses Stator (W)	Joules- losses Rotor (W)	iron- losses (W)	Mechanical losses (W)	Stray load losses (W)	$\Delta T$ (°F)	Efficiency (%)	Cos $\phi$ (%)
<b>Copper</b>	<b>281.72</b>	<b>110.63</b>	<b>91.50</b>	<b>28.15</b>	<b>23.30</b>	<b>129 (54°C)</b>	<b>88.49</b>	<b>82.44</b>
Aluminum	402.07	239.47	124.72	28.15	24.89	187 (86°C)	83.56	83.69

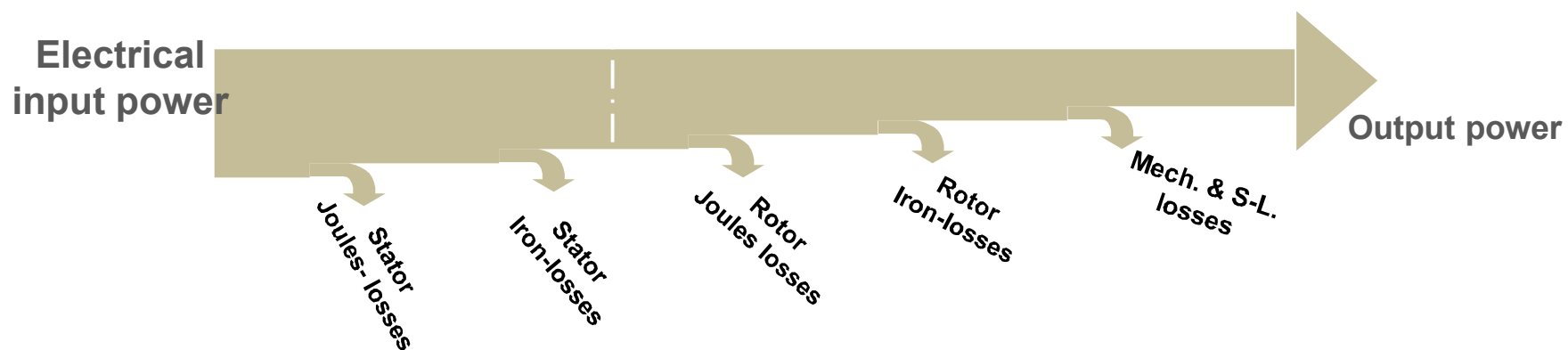

# Torque / Speed - 4kW induction motor:

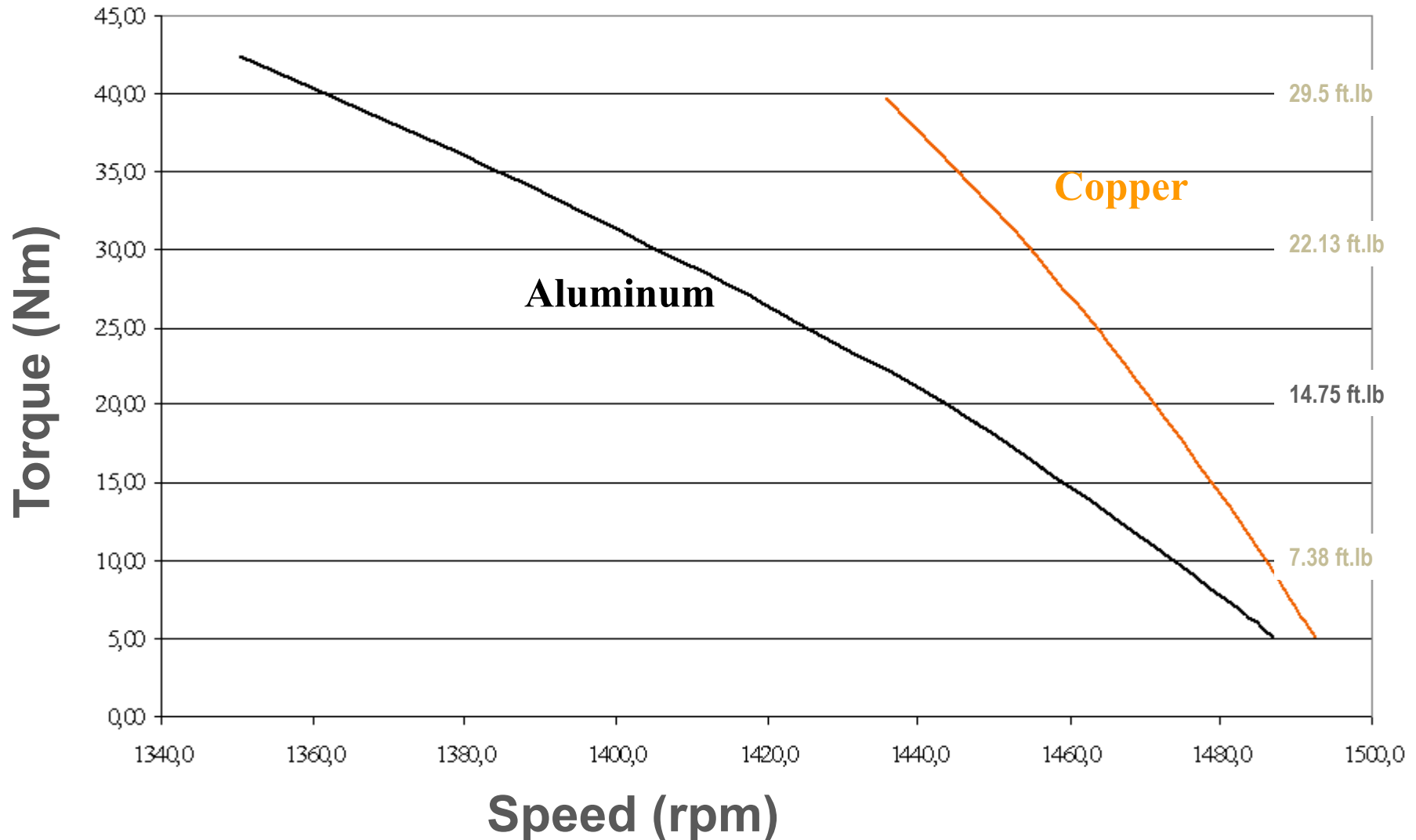

# Starting torque of a 4kW-Motor:

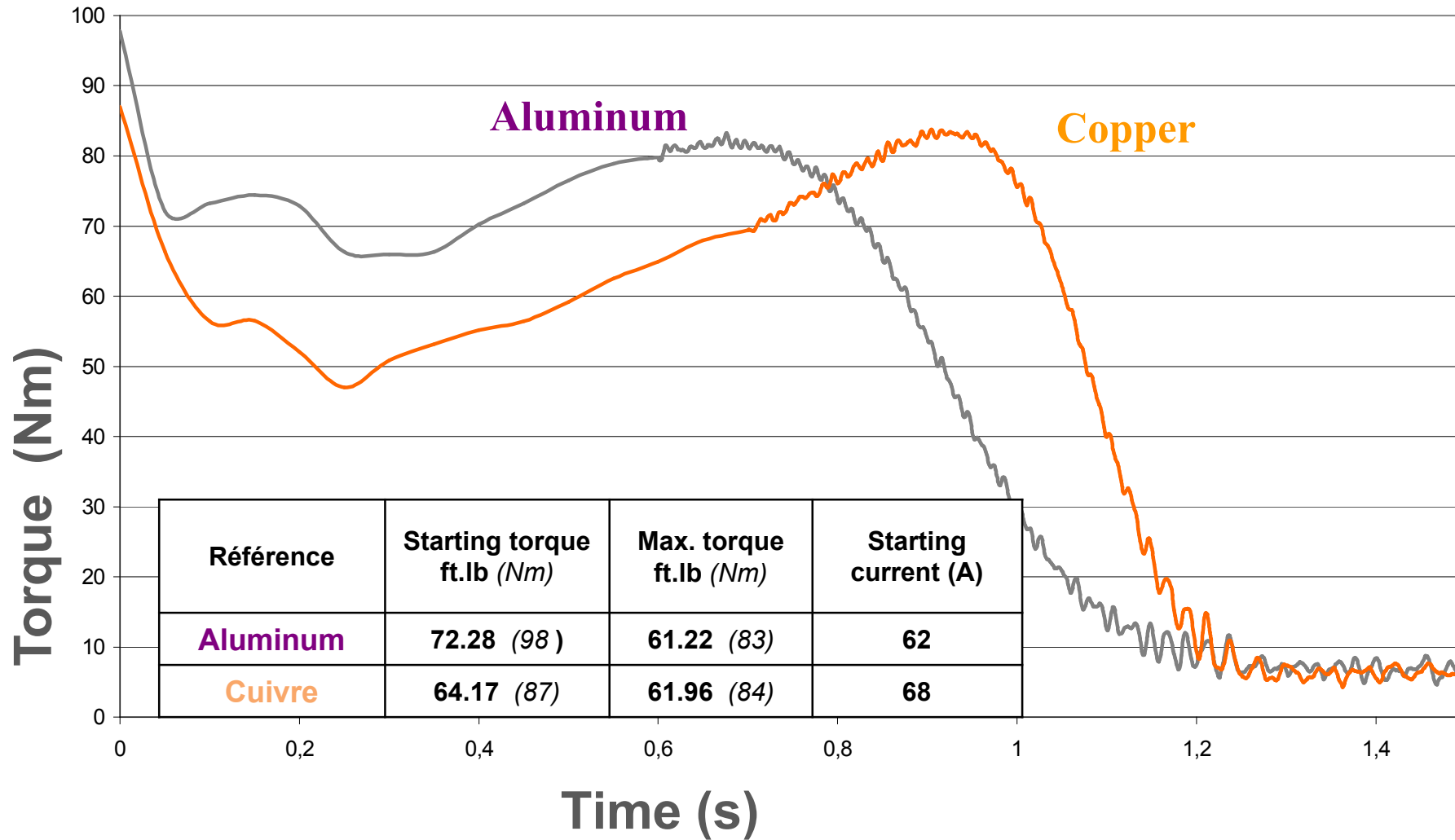

# Return on investment

The purchase of a motor represents 2.5% of its cost on its shelf life.



Single replacement of the aluminum rotor by a copper one :



Replacement of the aluminum rotor by a copper one and optimization of the motor :

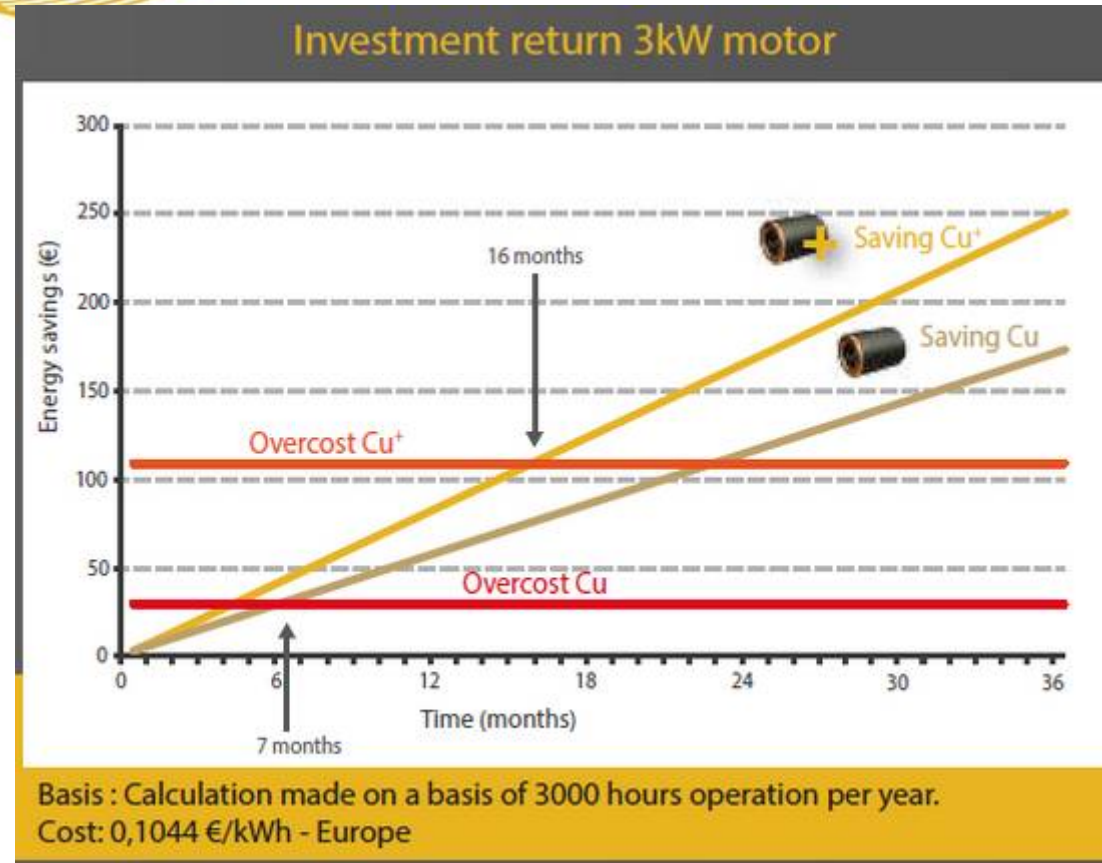

# Fields of application

## Fans



## Motors for high speed machining machines

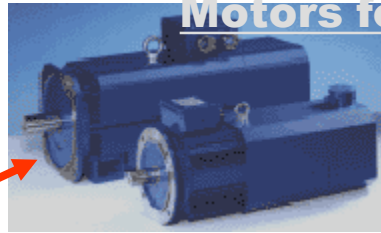

## High efficiency motors

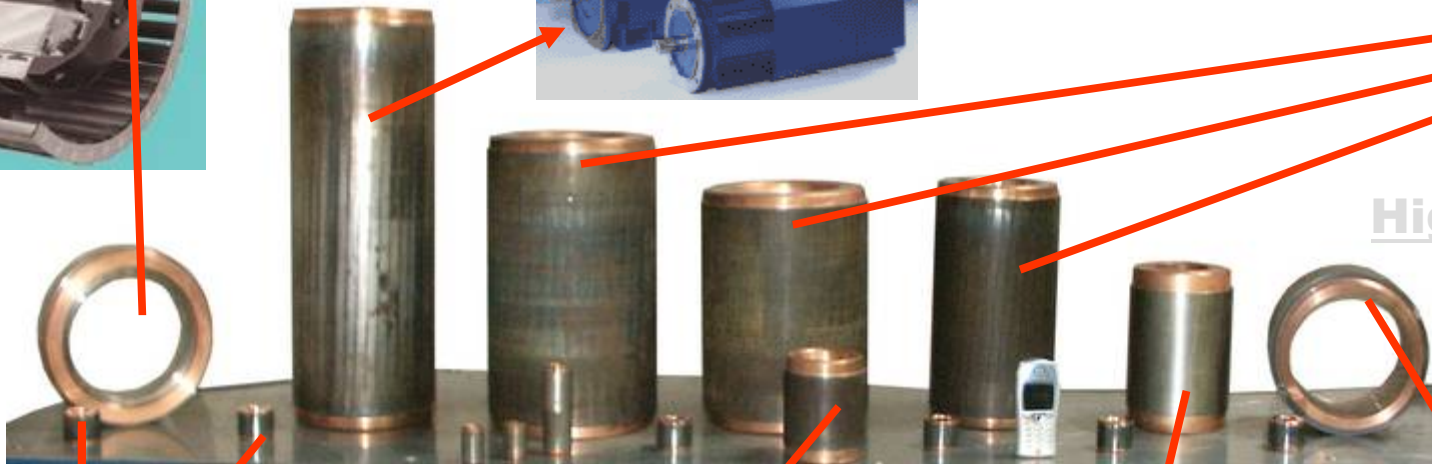

## Pumps



## Compressors



## Traction motors for EV



## Starter-Alternator



***Thanks a lot for your interest***