

PORENBRENNER
POROUS BURNER

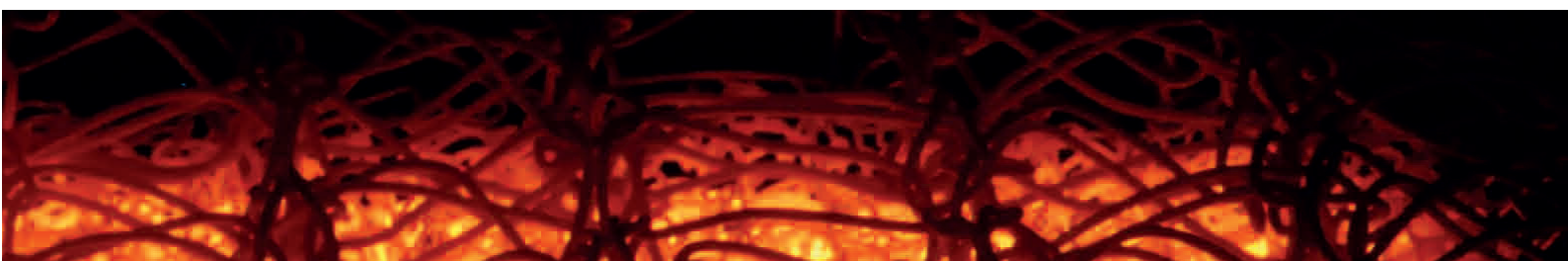

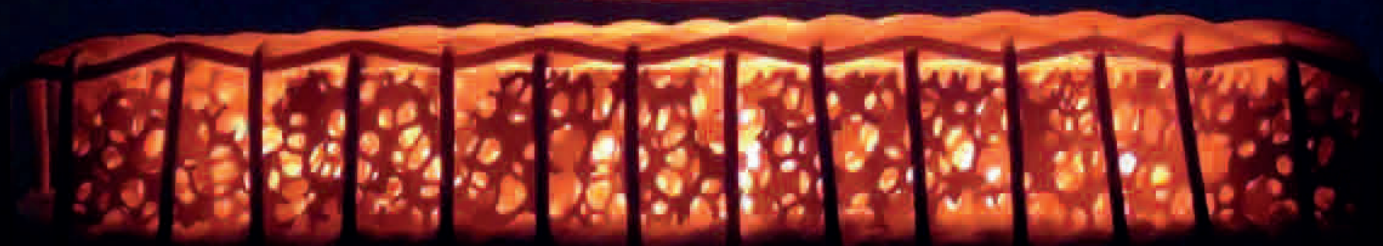
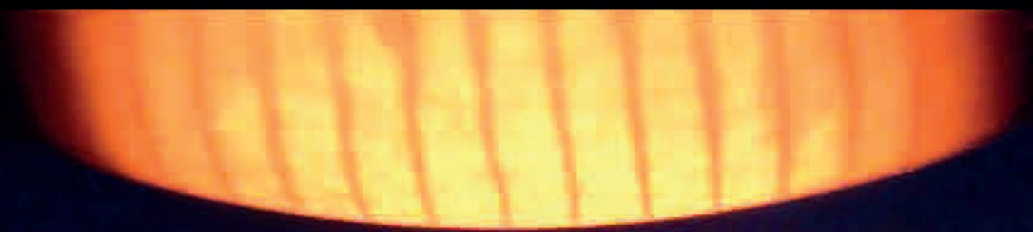
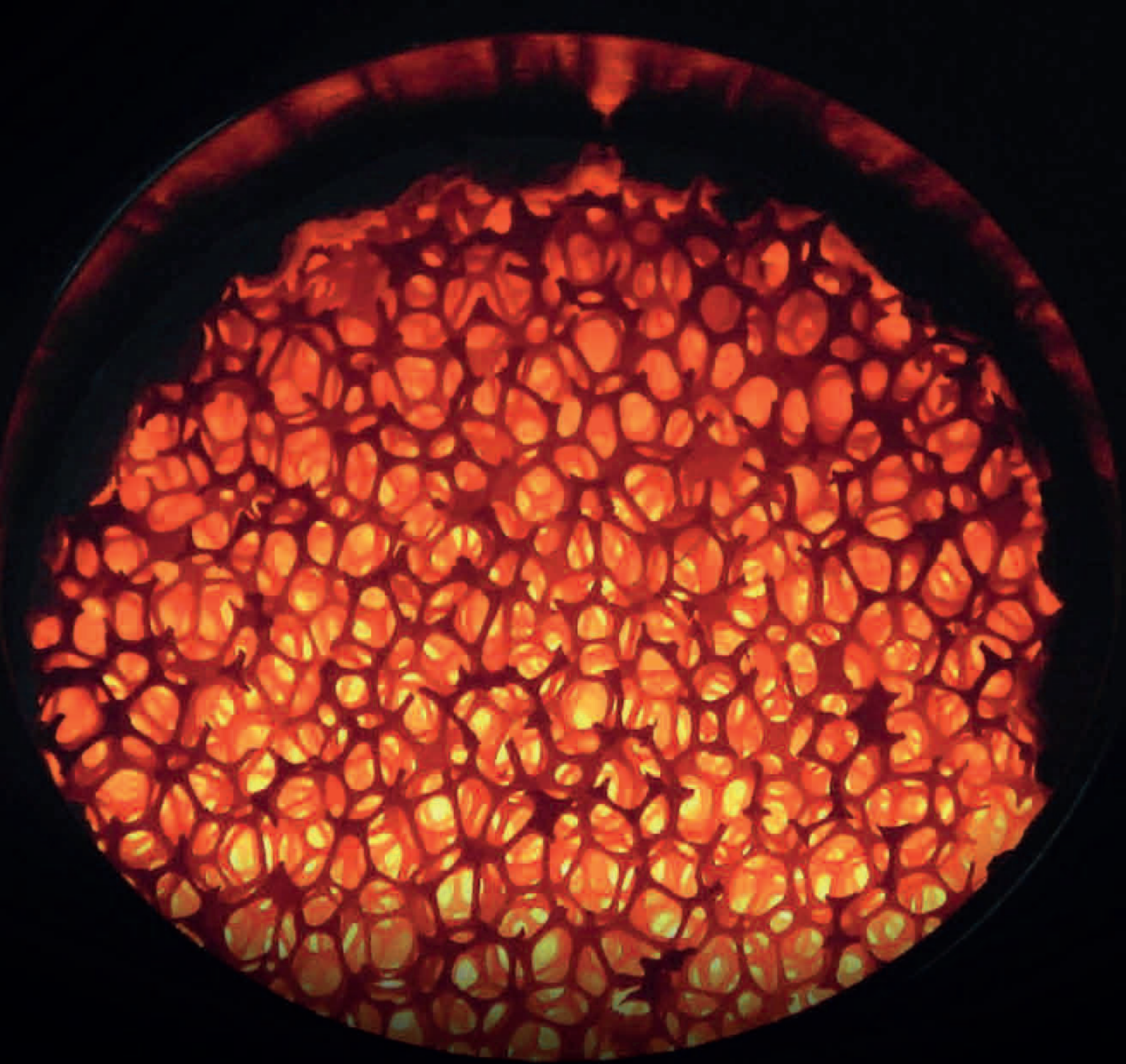

Porenbrennertechnologie

Porous Burner Technology

Das flammenfreie Verbrennungskonzept eines Porenbrenners basiert auf den Reaktionen eines Brenngas/Luft-Gemisches in einem porösen Medium. Ein vorgemischtes Brenngas/Luft-Gemisch durchströmt eine Flammensperre, ehe es vollständig in der Verbrennungszone reagiert. Damit unterscheidet sich die Porenbrennertechnologie grundsätzlich von anderen Verbrennungstechnologien, bei denen eine Flamme im freien Raum stabilisiert wird.

The flameless combustion concept of a porous burner is based on the reactions of a fuel gas/air mixtures that occur in porous media. A premixed fuel gas/air mixture passes a flame trap before reacting in the combustion zone. The porous burner technology therefore differs fundamentally from other combustion technologies, which rely upon a flame stabilised in free space.

HAUPTMERKMALE:

- Schadstoff- und geräuscharm
- Hohe Verbrennungsstabilität
- Brenngase: Erdgas, LNG, Biogas, Schwachgas
- Stufenlose Leistungsmodulation bis 1:20
- Hohe Leistungsdichte bis 2 MW/m²
- Strahlungswirkungsgrad bis zu 47 %
- Oberflächentemperaturen bis zu 1400°C
- Regelbare Oberflächentemperatur
- Modulierbare Strahlungsleistung
- Niedrige Abgasgeschwindigkeiten

KEY FEATURES

- Low emissions
- High combustion stability
- Fuel gases: natural gas, LNG, biogas, lean gas
- Power modulation range up to 1:20
- High power density up to 2 MW/m²
- Radiation efficiency up to 47%
- Surface temperatures up to 1400°C
- Adjustable surface temperature
- Adjustable radiation output
- Low exhaust gas velocities

Porenbrenner weisen ein hohes Potenzial für Energie- und Emissionseinsparungen auf. Darüber hinaus können vielfältige Bauformen der Brenner realisiert werden und an den jeweiligen Einsatzzweck optimal angepasste Brenner konzipiert werden. Durch eine präzise Temperaturregelung wird eine sehr gleichmäßige Guterwärmung erreicht. Probleme, die bei herkömmlichen Verbrennungstechnologien durch hohe Strömungsgeschwindigkeiten auftreten, werden vermieden.

Porous burners exhibit a high potential for energy and emission reduction. Furthermore, a tremendous variety of burner designs can be realised, allowing the design of burners optimised for particular purposes. Through its precise local temperature control, effective and homogeneous heating is achieved. The difficulties encountered with common combustion technologies due to high gas velocities are therefore avoided.

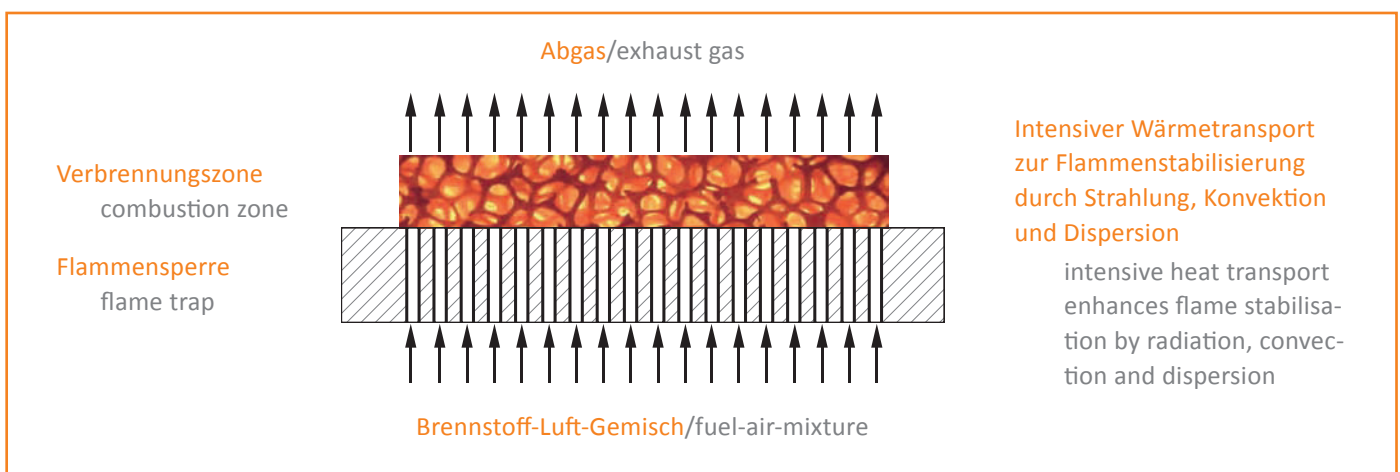

Porenbrenner

Porous Burner

Wir liefern kundenspezifisch ausgelegte Porenbrenner für eine große Bandbreite von Anwendungen. In vielen Bereichen kann der Einsatz von Porenbrennern die Prozesssicherheit und die Produktqualität steigern. Die gute Regelbarkeit der Porenbrenner erhöht die Effizienz von Anlagen und reduziert die Schadstoffemissionen. Unsere Auslegungstools helfen bereits in der Planungsphase den richtigen Porenbrenner für den jeweiligen Einsatzzweck zu konzipieren.

We provide customised porous burners for a wide range of applications. The use of porous burners leads to increased process safety and product quality. The precise control adjustments made possible by porous burner technology enhance efficiency and reduce pollutant emissions. Our software tools enable the design of individually customised porous burners for your particular applications.

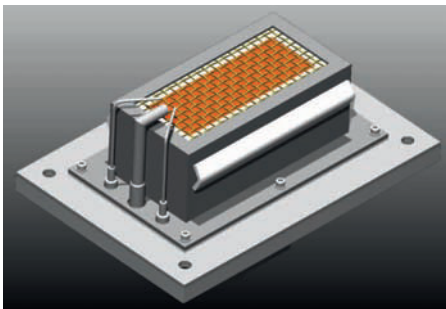

POR.R P15/A/67/185

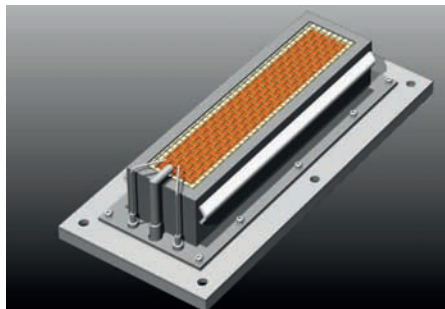

POR.R P35/A/67/370



POR.R P75/A/67/740

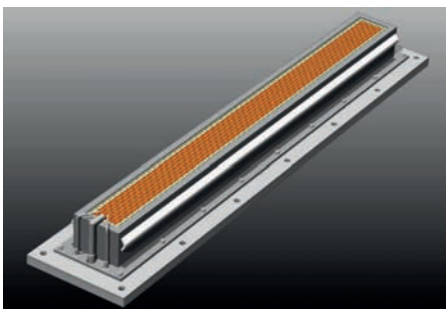

POR.R P115/A/67/1110

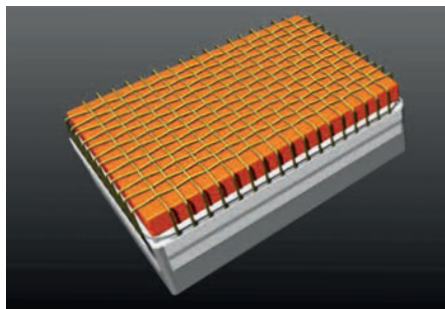

POR.R P30/A/135/185

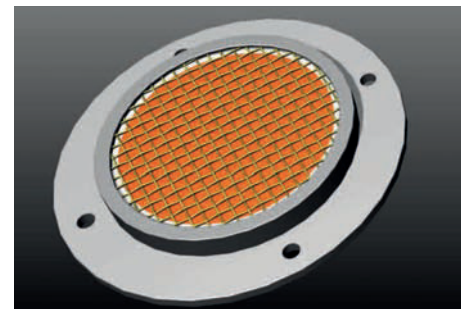

POR.C P30/A/170

Typ/type	Leistung/power	Abmessungen/dimensions
POR.R P15/A/67/185	1,5 kW - 15 kW	300mm x 181mm x 122mm
POR.R P35/A/67/370	3,5 kW - 35 kW	485mm x 181mm x 122mm
POR.R P75/A/67/740	7,5 kW - 75 kW	854mm x 181mm x 122mm
POR.R P115/A/67/1110	11,5 kW - 115 kW	1224mm x 181mm x 122mm
POR.R P30/A/135/185	3 kW - 30 kW	195mm x 145mm x 70mm
POR.C P30/A/170	3 kW - 30 kW	200mm x 73mm



Anwendungsbeispiel

Application Example



Zur Beheizung eines Pyrolyseofens wurden vier Porenbröner mit einer Gesamtleistung von $P = 300$ kW vom Typ P75/A/67/740 eingesetzt. Die Bröner wurden ohne zusätzlichen Aufwand in die ca. 200 mm dick isolierte Ofenwand eingesetzt. Der Bauraum des Ofens konnte auf Grund der flammenlosen Verbrennung und der niedrige Abgastemperatur vergleichsweise klein gehalten werden. In Verbindung mit einer internen Abgasumwälzung konnte die Reaktorwärnung zusätzlich verbessert werden. Durch die hohe Strahlungswärmeabgabe der Porenbröner wird die Aufheizzeit des Ofens gegenüber herkömmlichem Freiflammbröner fast halbiert. Die hohe Leistungsmodulation der Bröner erlaubt eine exakt regelbare Ofentemperatur bis zu 650°C .

A pyrolysis furnace was equipped with four porous burners of the type P75/A/67/740 with a total power of $P = 300$ kW. The burners were installed into the ca. 200 mm thick insulated furnace walls without additional effort. Due to the flameless combustion and low exhaust gas temperatures, the furnace cross-section could be kept very small. The reactor heating was further improved by the incorporation of internal exhaust gas recirculation. Due to the high radiation output of the porous burners, the heating time of the furnace was dramatically reduced compared to conventional free-flame burners. The high power modulation enables precisely adjustable furnace temperatures of up to 650°C .

Porenbröner werden in folgenden Branchen optimal eingesetzt:

- Aluminium
- Stahl
- Keramik
- Glas
- Kunststoff/Gummi
- Textil/Glasfaser
- Papier/Film
- Verpackung/Lebensmittel
- Thermisches Recycling
- Energie
- Chemie
- Sondergase

Porous burners are ideally suited for a wide range of industries:

- aluminium
- steel
- ceramics
- glass
- plastics/rubber
- textile/glass fiber
- paper/films
- packaging/food
- thermal recycling
- energy
- chemistry
- special gases





Issendorff Thermoprozesstechnik e.K.

Bahnhofstr. 19
91083 Baiersdorf
Deutschland

Telefon: +49 (0) 9133 769 7466
Telefax: +49 (0) 9133 769 7467

www.i-tpt.de
info@i-tpt.de

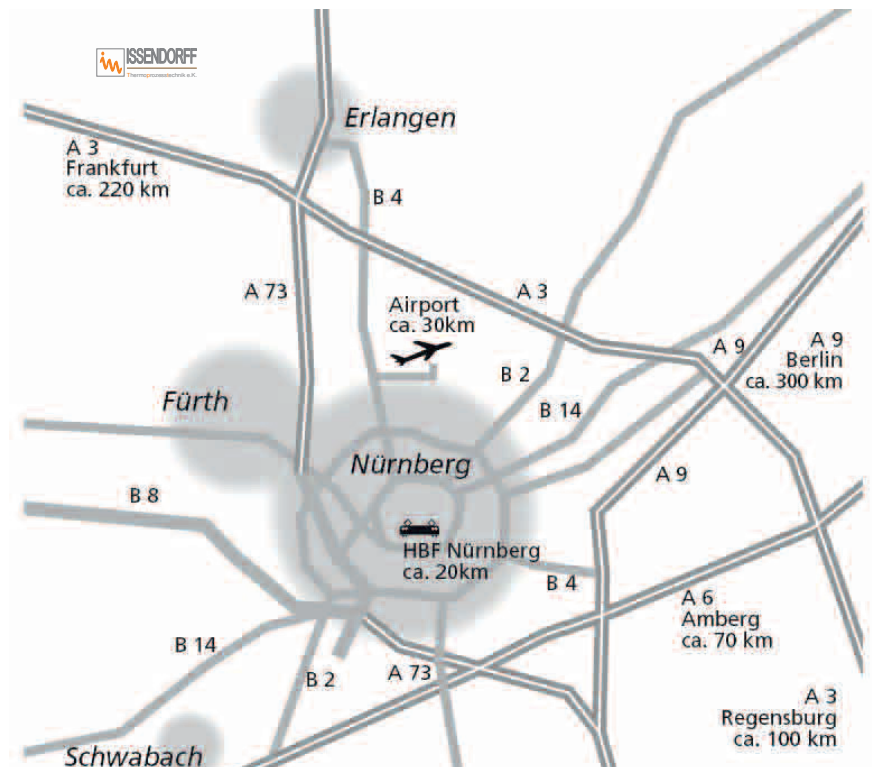

Technische Änderungen vorbehalten.
Copyright © 2014 Issendorff Thermoprozesstechnik e.K.
Alle Rechte vorbehalten.

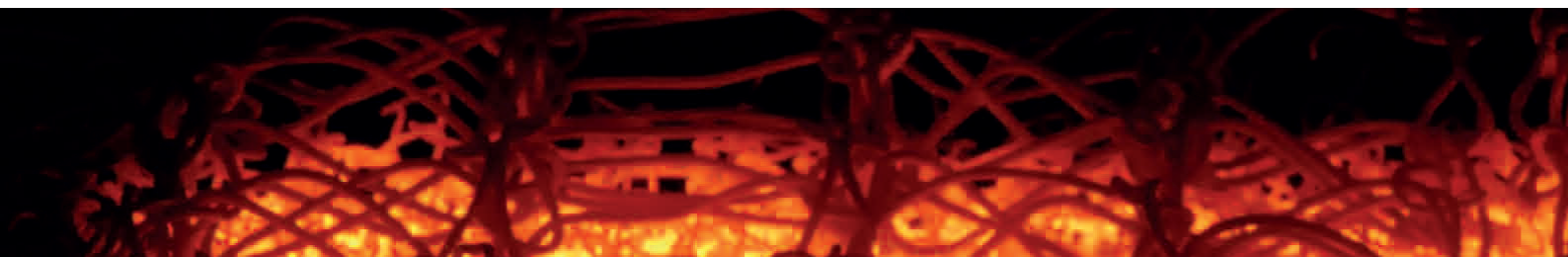

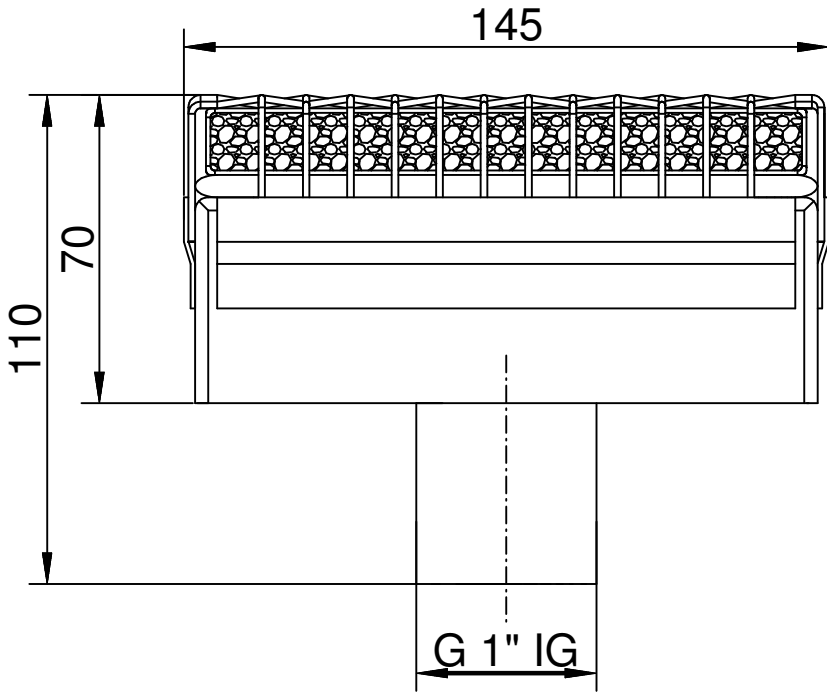

POR-R Typ: P30/A/145/19

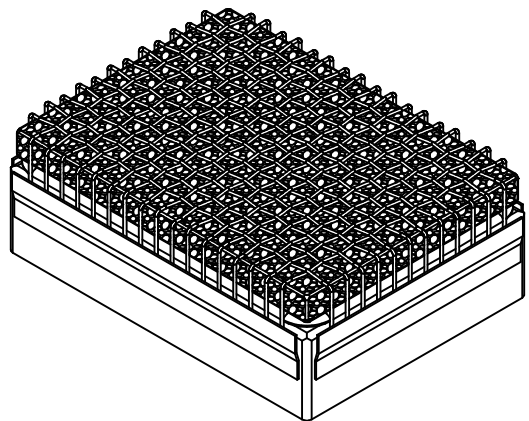
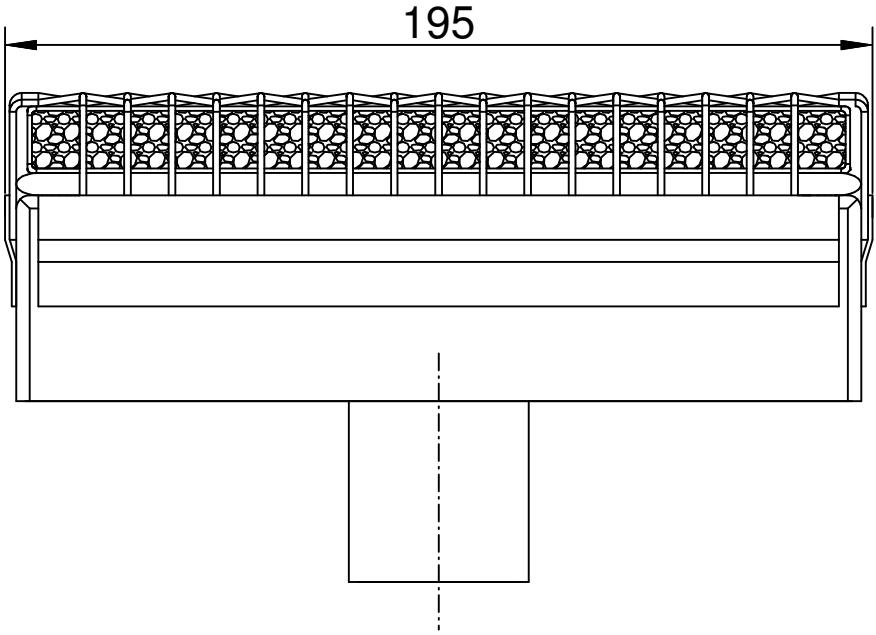

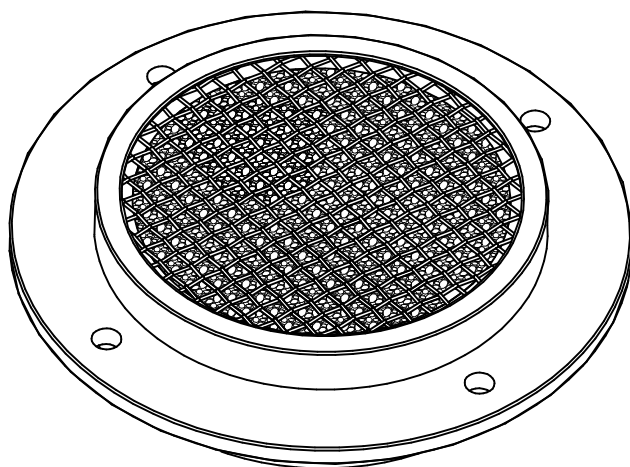

POR-C Typ: P30/A/170

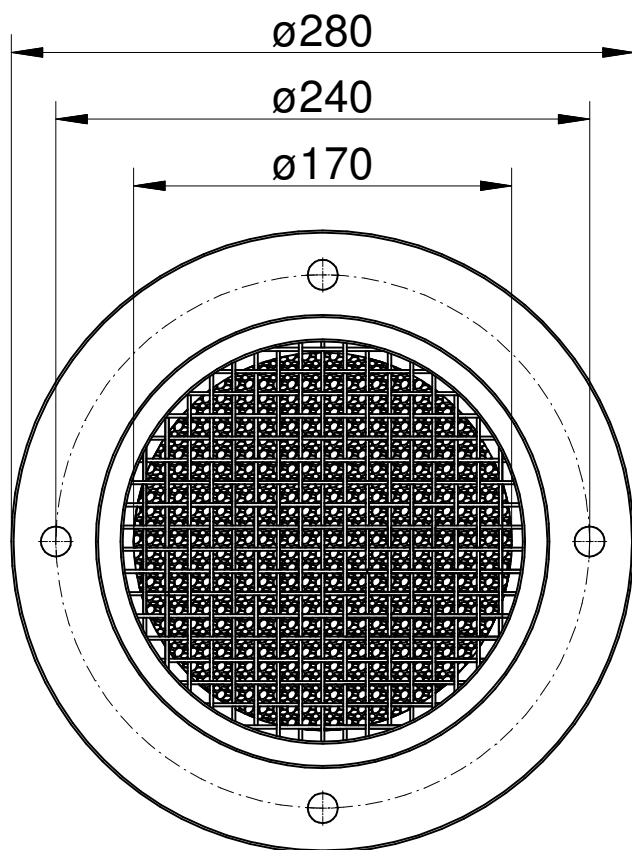
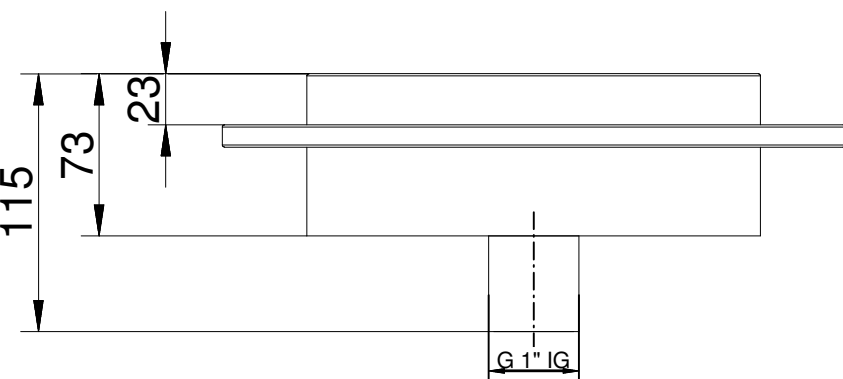

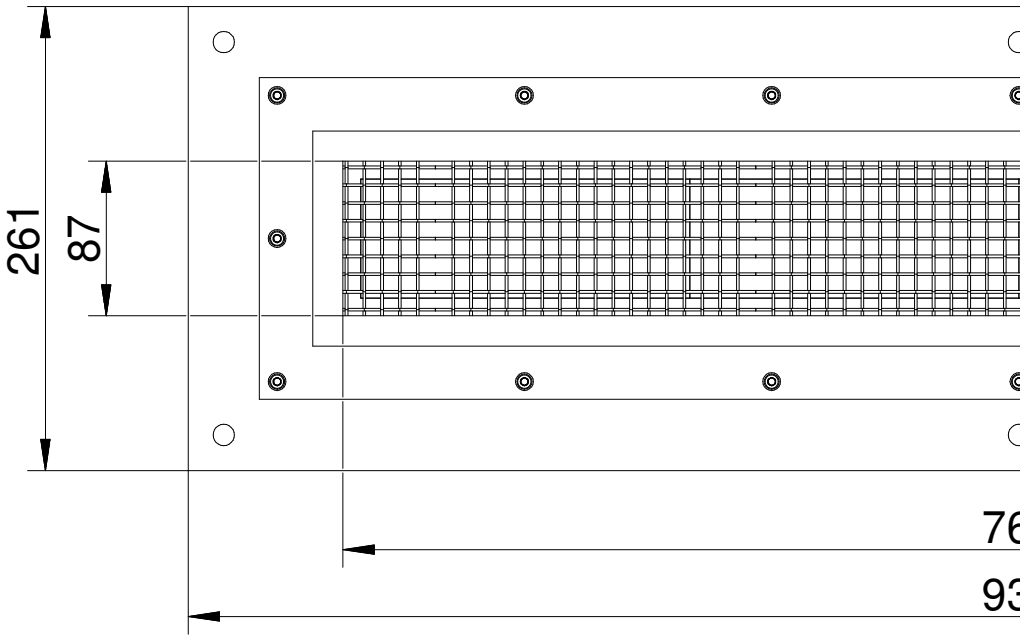
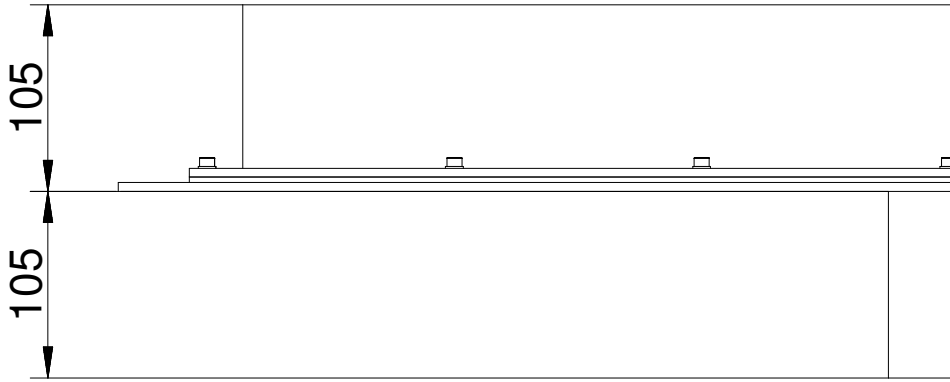

POR-R Typ: P75/A/67/740

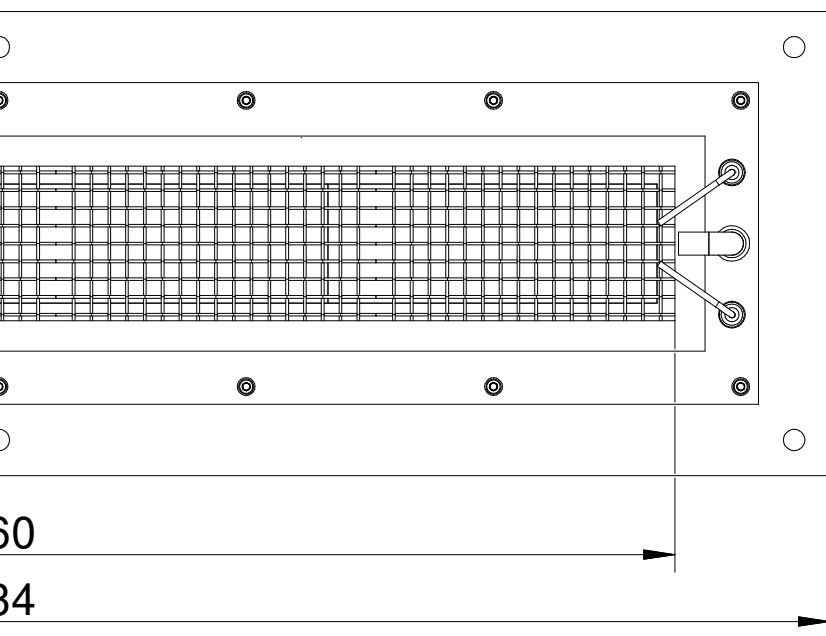
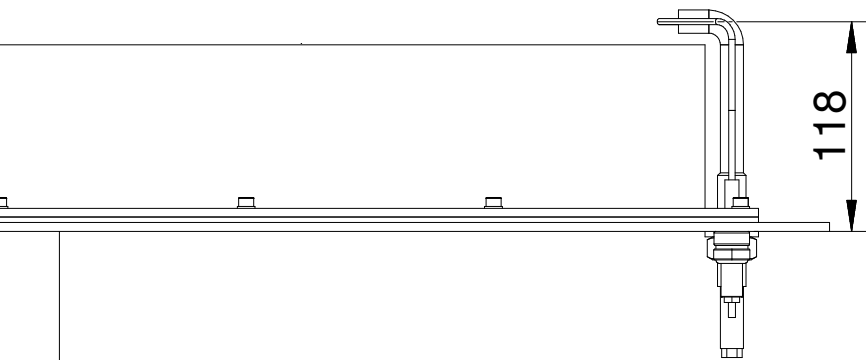

DEVELOPMENT OF A HIGH PRESSURE BURNER FOR INDUSTRIAL APPLICATIONS USING INERT POROUS MEDIA

M. Altendorfner⁽¹⁾, F. v. Issendorff⁽¹⁾, M. Dannehl⁽²⁾

⁽¹⁾ Institute of Fluid Mechanics, Friedrich-Alexander University of Erlangen-Nuremberg

⁽²⁾ Degussa GmbH, Process Technology & Engineering, Particle Processing

Abstract For a gas-dynamical initiated particle production reactor, a burner creating a hot gas with a pressure of 10 – 15 bars and of a predefined temperature (1300 – 1500 K), mass flow rate (40 – 100 g/s) and minimum oxygen mass fraction (10 – 40 %) was designed, constructed and tested under atmospheric conditions. Due to the low temperature level and the necessity of a stable temperature sequence, the application of inert porous media was chosen. For the application of inert porous media in high pressure combustion, a velocity stabilisation was employed. This form of stabilisation allows a wide power and excess air ratio range. First experimental investigations in atmospheric conditions of the burner show a stable and homogeneous temperature sequence and extremely low emissions of NO_x and CO.

Keywords: high pressure combustion in porous inert media

INTRODUCTION

Combustion processes under high pressures are widely used in different applications such as car engines, aero engines, stationary gas turbines and process plants etc. These different applications differ in the pressure ratio and the function of the combustion process. Car or aero engines are used for the propulsion and movement of the vehicle. Thus, these applications are defined by highly instationary processes and vibrations as well as the demand of fast process adjustments. Stationary gas turbines and processes in industrial plants however, require mainly stationary conditions and cause far less vibrations under normal operation conditions.

For a particle production reactor, a burner creating a hot gas with a pressure of 10 – 15 bars and of a predefined temperature (1300 – 1500 K), mass flow rate (40 – 100 g/s) and minimum oxygen mass fraction (10 – 40 %) was

designed, constructed and tested under atmospheric conditions. Due to the low temperature level and the necessity of a stable temperature sequence, the application of inert porous media was chosen.

In the porous medium based combustion, the reactions of the fuel/air mixture take place in the voids of an inert porous medium and heat up the surrounding structure [1]. Due to the high heat conductivity and emissivity of the solid, a highly effective heat transport can be achieved resulting in a uniform temperature distribution, and thus, to low NO_x and CO emissions. Moreover, the incoming fuel/air mixture is preheated due to the solid's heat transport (conduction and radiation) even against the flow direction, leading to up to 30-times higher burning velocities. Another advantage of the employed porous media is the high power modulation range of the burners with a very small necessary combustion volume. Furthermore, the thermal inertia of the solid porous structure results in a high combustion stability even superior to the one of non-premixed flames [2]. These advantageous characteristics can be used to shift the excess air ratio to very lean conditions or to use fuels with very low calorific value [3].

For the application of inert porous media in high pressure combustion, a velocity stabilisation was employed. This form of stabilisation allows a wide power and excess air ratio range. Previous experimental investigations of different porous materials and structures yielded, that the best burner performances were achieved with SiSiC foams and Al_2O_3 mixture structures [4].

The burner housing was designed and built according to the German pressure vessel directive and certified by the German TÜV. The objectives of the first experiments under atmospheric conditions were the stabilisation of the flame, the ignition and start up behaviour, the temperature sequence and level.

BURNER DESIGN

For the production of the hot exhaust gas flow, methane, air and for specific operational conditions additional oxygen will be mixed and fed to the high pressure burner.

Due to the minimum oxygen concentration of 10 – 40 mass% in the exhaust gas determines the necessity of an additional oxygen mass flow for

values above 13 mass%. The additional oxygen mass flow will be mixed with the air and methane mass flow before entering the combustor.

The exhaust gas mass flow rate range of 40 – 100 g/s defines the maximum and minimum necessary power of the burner. For the design, the power modulation range was constituted to be 1:10. As a design point for the largest cross sectional area of the burning chamber, the norm conditions of the burner were taken. The norm conditions are defined by a pressure of 10 bars, an exhaust gas mass flow rate of 100 g/s and an exhaust gas temperature of 1300 K.

Calculation of the required mass flow rates

The above explained exhaust gas requirements were used to calculate the mass flow rates of methane, air and oxygen as a function of the exhaust gas mass flow rate, the exhaust gas temperature and the oxygen concentration in the exhaust gas. The calculation procedure assumed that methane and air were combusted with an estimated excess air ratio (starting value) resulting in a specific adiabatic flame temperature. Following this, the amount of oxygen mass flow needed to meet the required oxygen concentration was determined and the theoretical mixing temperature of the methane/air-exhaust gas and the additional oxygen was calculated. This resulting temperature was compared to the required one. Whenever the absolute value of the difference exceeded 2 K, the estimated excess air ratio of the methane/air combustion was adjusted.

The resulting temperature of this assumed process (first methane and air combustion, then mixture with oxygen at room temperature) equals the temperature of the real process where air, methane and oxygen are premixed before the mixture is combusted at adiabatic conditions.

The following diagram shows the resulting mass flow rates for the norm conditions of the burner (a pressure of 10 bars, an exhaust gas mass flow rate of 100 g/s and an exhaust gas temperature of 1300 K):

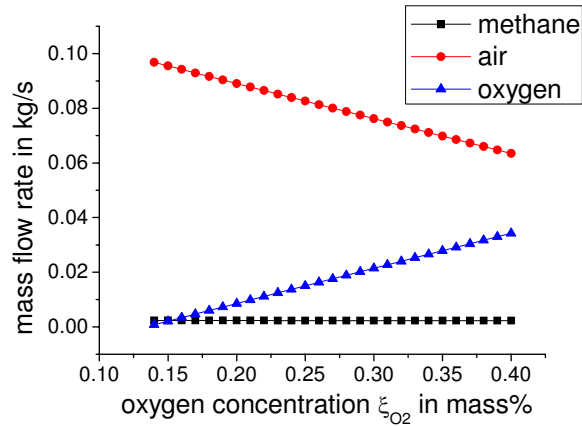

Figure 1 Calculated mass flow rates for the norm conditions of the burner

As can be seen from *Figure 1*, the methane mass flow rate is nearly constant over the complete oxygen concentration range. For the particle production process a minimum oxygen concentration in the hot gas flow is necessary. Oxygen concentration values below 13 mass% at a temperature level of 1300 K can not be reached with the described process; so that for those oxygen concentrations a constant value of 13 mass% will be fixed.

For an increased oxygen concentration in the exhaust gas, the oxygen mass flow rate has to be increased, whereas the air mass flow rate has to be decreased. The following equation shows the dependency of the resulting mixing temperature T_{out} of the hot exhaust gas and the cold oxygen mass flow:

$$T_{out} \approx \frac{m_{exhaust} \cdot cp_{exhaust} \cdot (T_{ad} - T_0)}{m_{ges} \cdot (cp_{O_2} \cdot x_{O_2} + cp_{exhaust} x_{exhaust})} \quad (1)$$

with

$$m_{ges} = (m_{exhaust} + m_{O_2}) = \text{const.}$$

An increase in the oxygen concentration results in a decreasing exhaust gas mass flow while the nominator in the equation above remains more or less constant (the total mixture mass flow rate is kept constant). For a constant mixing temperature T_{out} , the product $cp_{exhaust} \cdot (T_{ad} - T_0)$ has to be

increased. This can be accomplished by reducing the excess air ratio of the methane air combustion.

Figure 2 shows the dependency of the power and the excess air ratio over the complete oxygen concentration range. As can be seen, the excess air ratio decreases with increasing oxygen concentration from 2.5 to 1.7. The necessary power for the norm conditions are 120 kW.

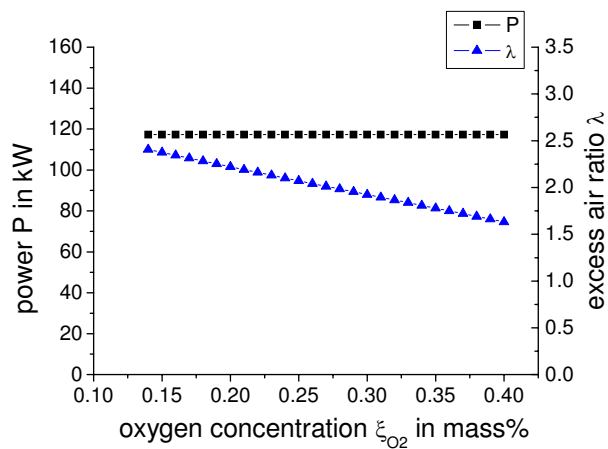

Figure 2 Power and excess air ratio as a function of the oxygen concentration for norm conditions

The maximum required process temperature is 1500 K. The calculation of the mass flow rates of the different gases, the power needed and the excess air ratio for the theoretical methane air combustion and later mixture with oxygen were also calculated.

The following figure shows the power and excess air distribution for the maximum required temperature of 1500 K (mass flow rate 100 g/s, pressure 10 bars):

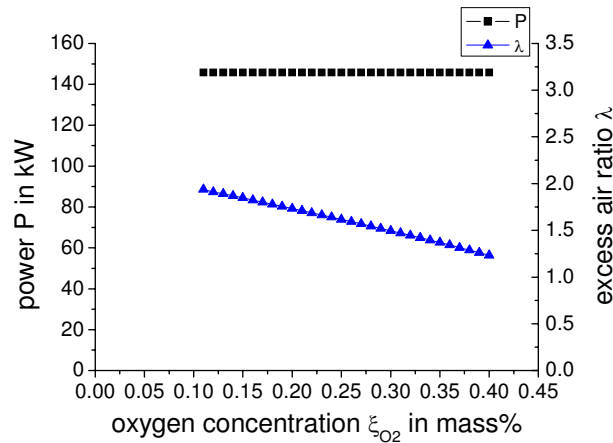

Figure 3 Power and excess air ratio for a mass flow rate of 100 g/s, a temperature of 1500 K and a pressure of 10 bars.

As can be seen, the burner power for the increased hot gas temperature is 145 kW. The increased mixture temperature compared to the norm conditions is achieved by reducing the excess air ratio of the methane air combustion. Thus, the overall power has to be increased to meet the required hot mass flow simultaneously.

Design of the conically shaped combustion zone

Using a velocity stabilization, the operational range of the burner is a function of the flow velocity and the burning velocity. The flow velocity strongly depends on the gas mixture density and the geometry of the burning chamber. Increasing the pressure in the burning chamber the gas mixture density increases proportionally, assuming the ideal gas law. The flow velocity of the gas mixture is reduced proportionally to the density increase, for the same fuel/air mixture with a constant mass flow rate.

The burning velocity on the other hand is a function of the adiabatic flame temperature, the fuel and oxidizer and the operational pressure. An increase in the adiabatic flame temperature of a methane air flame by reducing the

excess air ratio for example leads to an acceleration of the burning velocity, whereas an increase of the operational pressure reduces the burning velocity.

The burning velocities shown in *Figure 4* were calculated with Chemkin 3.7/ Premix using GriMech 3.0:

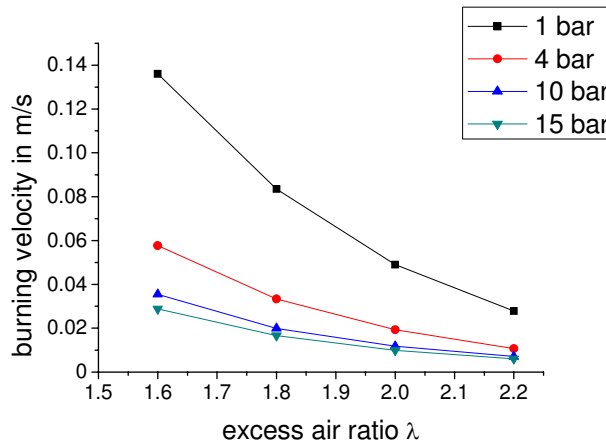

Figure 4 Burning velocities of methane air flames for different pressures and excess air ratios

As can be seen in *Figure 4* the burning velocity decreases significantly by increasing the operational pressure from 1 – 10 bars. The largest decrease can be observed for low excess air ratios. The reduction of the burning velocity from 10 – 15 bars however is much less significant, especially for high excess air ratios almost no difference can be stated. The highest excess air ratio in the diagram represents roughly the conditions of the particle production process temperature.

Thus, for the design of the combustion chamber, the operational pressure of 10 bars is chosen. *Figure 3* shows the maximum required power for the adiabatic process. For increased burner flexibility, the maximum design power was set to be 200 kW. Due to the high heat recuperation in a porous burner, the burning velocities of combustion processes taking place in the voids of an inert porous medium are highly increased (experience shows that this increase can reach up to 30 times). Therefore, for the design of the combustion chamber, an increase of the burning velocity of 20-times due to the presence of the porous material was assumed. Thus, the maximum

necessary diameter of the cone was calculated to be 250 mm. For a power turn down ratio of the burner of 1:10, the minimum necessary diameter of the combustion chamber is 50 mm. For an increased safety, a diameter of 32 mm was chosen. This conically shaped porous structure causes a pressure drop of about 600 mbar for the norm conditions of the burner.

Intensive experimental investigations of the velocity stabilization of flames in porous media show that the maximum possible opening angle of the structure without detachment of the flow in the geometry is 20° [4].

In this conical geometry, the flame is only stabilized. For the oxidation process, however a minimum reaction volume is necessary to ensure the minimum residence time of the reacting gases for a complete CO oxidation. Therefore, the cone had to be prolonged with a cylindrical part with a length of 200 mm.

Due to the fact that the operational range of the burner is a function of the adiabatic flame temperature and the pressure, the operational range of the burner for 10 bars exceeds the required 200 kW when flame temperatures above the ones required for the particle production process can be operated. The upper temperature limit of the burner equals the maximum allowed operation temperature for the SiSiC foam of 1550 °C. The following diagram shows the dependency of the operational range from the adiabatic flame temperature for different burner powers for a pressure of 10 bars:

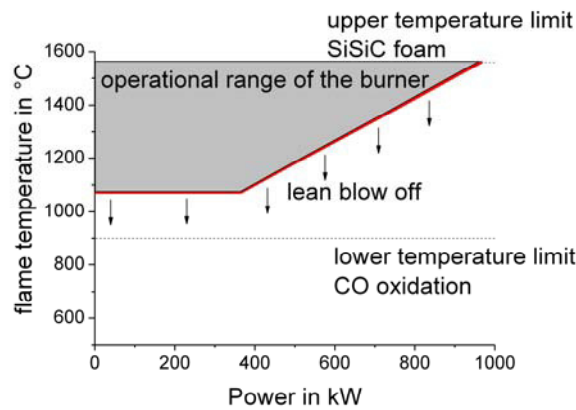

Figure 5 Operational range of the burner for different adiabatic flame temperatures and powers at a pressure of 10 bars

To ensure only very small heat losses, the insulation around the porous structure was chosen to be at least 50 mm. The burner housing was designed according to the German AD-2000 Merkblatt for pressure vessels.

The completed design can be seen in *Figure 6*:

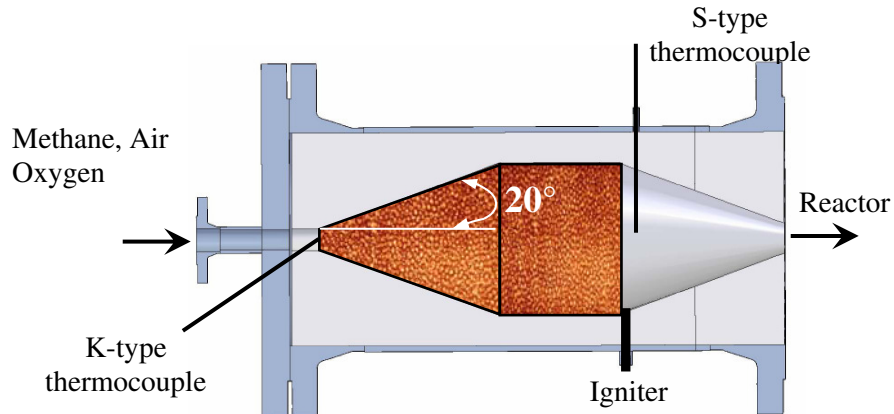

Figure 6 Burner design with housing

ATMOSPHERIC EXPERIMENTS

In accordance with the German TÜV, for the detection of a flash back, K-type thermocouples are installed facing the entering diameter of the combustion chamber. The flame detection is performed with S-type thermocouples located downstream the porous material. A safety shut down will be initiated whenever one of the K-type thermocouples measures a temperature above 100 °C, or one of the S-type thermocouples either measures a temperature below 640 °C or above 1300 °C. The ignition of the fuel air mixture is performed using a high energy igniter especially designed for gas turbines.

The experimental setup is shown in *Figure 7*. The process air comes from a compressor whereas the gases oxygen and methane are stored in gas bottles with a pressure of 200 bars. The mass flow rates of each material are controlled with thermal mass flow controllers from Bronkhorst. Before the mixing takes place, two safety valves were installed in each gas line. For air

and oxygen, Fema Honeywell safety valves are used; for methane, safety valves from UNI Geräte were chosen. To ensure the leak tightness of the safety valves, an automatic examination using three pressure sensors has to be performed before start up. In a static mixer of Sulzer, the gases are homogeneously mixed before entering the combustion chamber. During the atmospheric tests, the exhaust gas flows into a chimney. Later, during the particle production process, the burner will be directly connected to the particle production reactor.

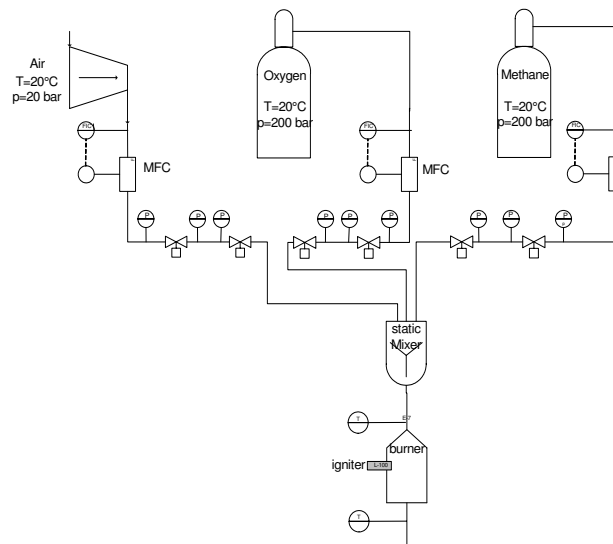

Figure 7 Experimental setup

First experiments with the burner were performed under atmospheric conditions. Thereby the ignition power of 20 kW with an excess air ratio of 1.6 showed the best start up behaviour of the burner. The temperature distribution of the thermocouples located downstream of the porous material during start up is shown in *Figure 8*. As can be seen, 10 seconds after starting the ignition, the temperature downstream of the burner exceeds 650 °C and rises up to 1180 °C. Observations of the flame revealed that the

oxidation process takes place above the porous material directly after ignition. As soon as the porous structure is heated up, the flame gradually moves into the foam. This process reduces the temperature downstream of the burner. In the following time, the surrounding material is heated up and reaches steady state after about 10 minutes of operation.

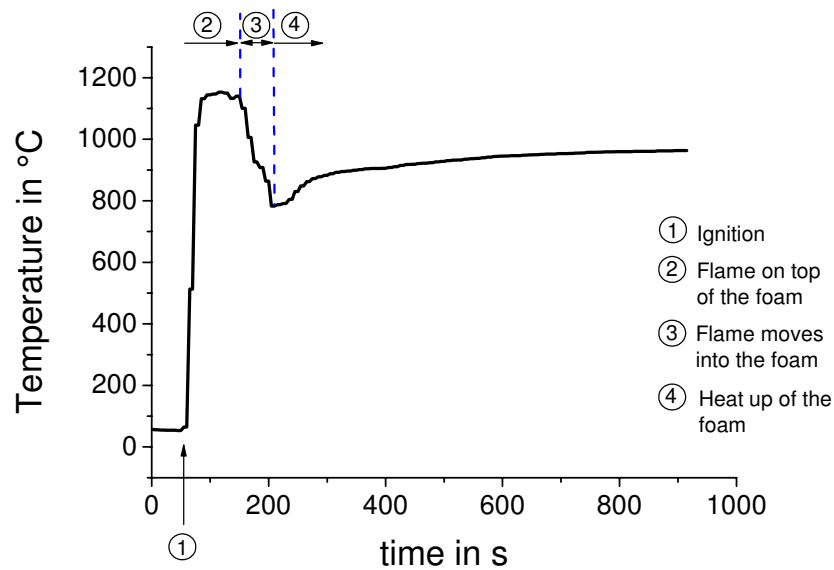

Figure 8 Temperature development during start up

The atmospheric investigation of the burner included the transient temperature development for changes in the excess air ratio as well as power. As soon as the burner reached almost steady state, CO and NO_x emissions were measured in the exhaust gas.

Figure 9 shows the temperature distribution upstream of the burner changing the excess air ratio from 2.2 to 2.0 and then to 1.8 for a power of 10 kW. Whenever the excess air ratio was changed, the temperature stayed constant for about 10 minutes. After this initial time, the temperature gradually changed until reaching steady state after about 20 minutes. A similar behaviour was observed whenever the burner power was changed.

The NO_x - and CO-emissions for different powers and excess air ratios can be seen in *Figure 10*. Over the complete power and excess air modulations range measured, the emissions stayed below 10 ppm.

Furthermore, measurements for 1030 °C and an exhaust gas mass flow rate of 0.015 kg/s for different oxygen concentrations (13, 20, 30 and 40 mass%) were performed. The transient temperature distribution is shown in *Figure 11*. As can be seen, the temperature downstream of the burner is constant with a maximum deviation of 2 K per concentration. The NO_x - and CO-emissions measured did not exceed 10 ppm.

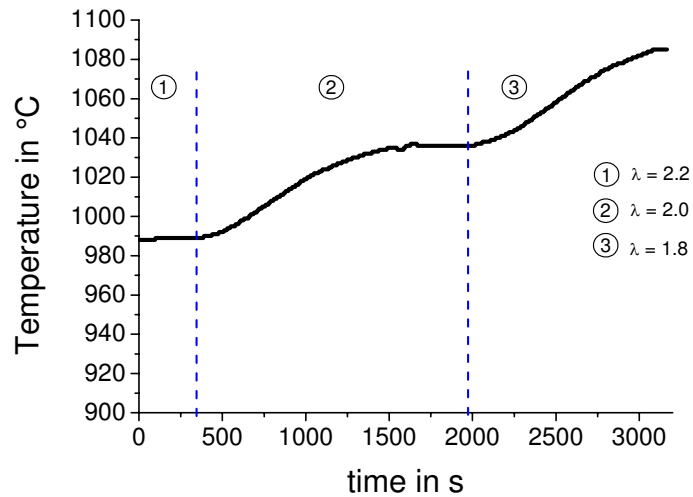

Figure 9 Temperature distribution for a power of 10 kW changing the excess air ratio from 2.2 to 2.0 and then to 1.8

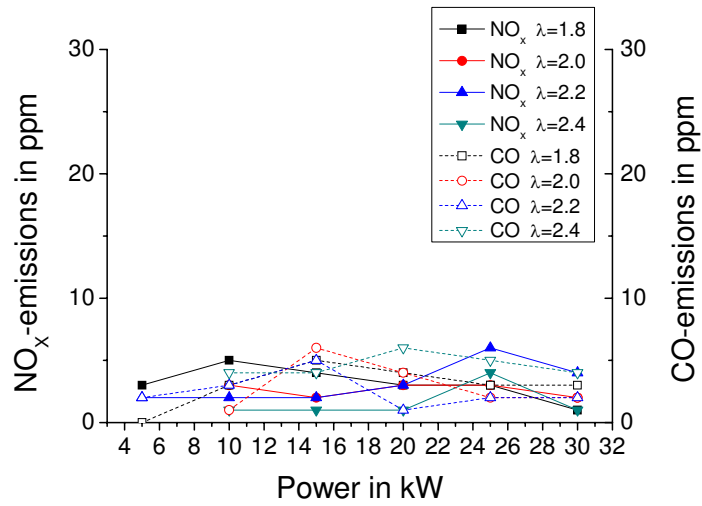

Figure 10 NO_x- and CO-emissions for different powers and excess air ratios

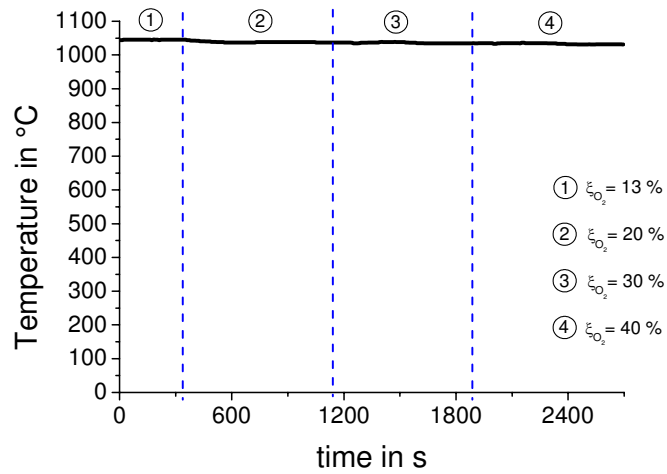

Figure 11 Temperature distribution for different oxygen concentrations

SUMMARY

A high pressure burner with inert porous media for industrial applications was designed, constructed and tested under atmospheric conditions. The performed experiments show that the flame stabilises in the porous structure over the designed power modulation range. Moreover, the experiments revealed that over the complete power modulation range tested, the NO_x- and CO-emissions never exceeded 10 ppm. It was shown that an exhaust gas temperature of 1030 °C for different oxygen concentrations up to 40 mass% could be achieved with a very constant temperature sequence. Future experiments will focus on the determination of the pressure influence on the power modulation range and emissions of the burner.

ACKNOWLEDGEMENTS

We would like to express our gratitude to Degussa GmbH, Process Technology & Engineering, Particle Processing for the funding of this work and the good collaboration during this project.

NOMENCLATURE

cp_{exhaust}	heat capacity of the methane and air combustion products
cp_{O_2}	heat capacity of oxygen at room temperature
m_{ges}	total mass flow of the mixture
m_{exhaust}	mass flow of the methane and air combustion products
m_{O_2}	mass flow of oxygen
T_{ad}	adiabatic flame temperature of the methane and air combustion
T_{bez}	reference temperature
T_{out}	mixture temperature, required temperature by the process
x_{exhaust}	mass fraction of the combustion products
x_{O_2}	mass fraction of oxygen

REFERENCES

1. D. Trimis, F. Durst, "Combustion in a Porous Medium - Advances and Applications", *Combust. Science & Technology*, Band 121, S. 153-168, 1996.
2. D. Trimis, "Stabilized combustion in porous media; principles and applications", *Clean Air: International Journal on Energy for a Clean Environment* begell house, inc., (in press), 2004
3. S. Diezinger, M. Steven, P. Talukdar, Z. Al-Hamamre, F. von Issendorff, D. Trimis, „Numerische und experimentelle Untersuchung von Verbrennungsvorgängen niederkalorischer Gase in Porenbrennern“, 22. Deutscher Flammentag Braunschweig, September 2005
4. A. Bakry, "Investigation of adiabatic combustion in porous inert media for an elevated pressure and temperature burner and atmospheric plant oil burner", PhD Thesis, Institute of Fluid Mechanics University of Erlangen-Nuremberg, 2001.