

Technische Profile

aus thermoplastischen Kunststoffen

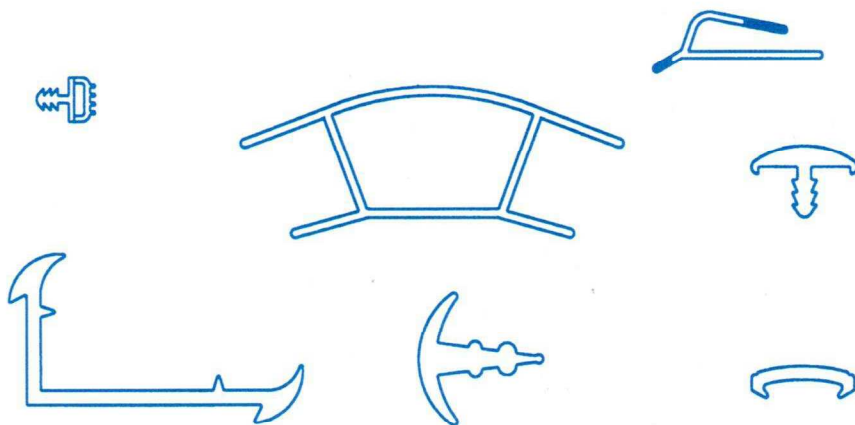

Estorfer Kunststoffbetrieb GmbH

Zum Finkenberg 12
D-31629 ESTORF
Telefon: +49 5025 9707-0
Telefax: +49 5025 9707-69
E-mail: info@estorfer.de
www.estorfer.de

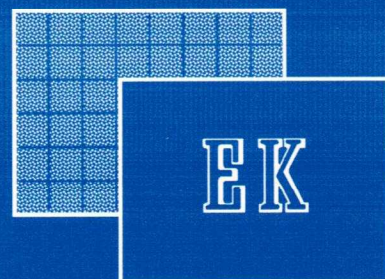
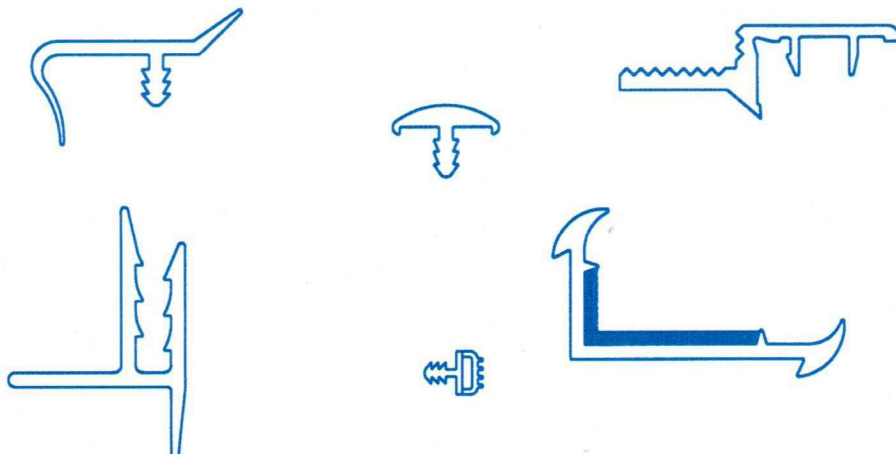

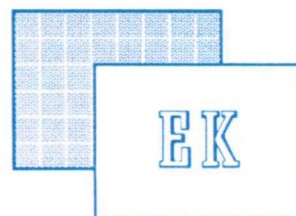

Estorfer Kunststoffbetrieb GmbH

Die Estorfer Kunststoffbetrieb GmbH stellt zahlreiche Spezialprofile her, die oft ein wichtiger Baustein des Endproduktes sind. Unsere Profile erfüllen die Qualitätsanforderungen, die u.a. an Härte, Verschleißfestigkeit, Konstruktion und Haltbarkeit gestellt werden.

Unsere Spezialitäten sind u.a.

- **Coextrudierte Profile aus Hart/Weich-PVC auch mehrfarbig**
- **Beschichtungen mit Butyl (Kautschuk) und doppelseitigen Selbstklebebandern**
- **Formextrudierte Profile mit erhabener, geformter Oberfläche**
- **Dekorbeschichtung derzeit ca. 100 verschiedene Holzdekore und ca. 10 Metalldekore**
- **Konfektionierung nach Bedarf (Ablängen, Stanzen, Bohren, Verschweißen, Bedrucken)**

Wir fertigen Profile aller Art nach Muster oder Zeichnung, vorwiegend aus PVC;
bei Bedarf entsprechender Mengen aber auch aus anderen thermoplastischen Kunststoffen wie PE, PS, oder TPE.

Partnerschaft beginnt beim gemeinsamen Entwurf und in der anwendungsspezifischen Entwicklung. Für die dann folgende Anfertigung der Sonderprofile sind wir bestens gerüstet. Ein eigener Werkzeug- und Vorrichtungsbau, ein eigenes Labor und unser Know-How aus vier Jahrzehnten lassen auch für Ihr Problem die richtige Lösung finden.

Bei der Estorfer Kunststoffbetrieb GmbH finden Sie alles in einer Hand: Angefangen von der Beratung bis hin zur Auslieferung. Deshalb sind wir seit 40 Jahren auch Partner vieler Industriezweige.

Wenden Sie sich an unsere Fachberater, wir arbeiten Ihnen gern ein für Sie kostenloses und unverbindliches Angebot aus. Alles, was wir brauchen, ist entweder eine Zeichnung, eine bemaste Handskizze oder ein Muster. Hilfreich wären noch Angaben über den Verwendungszweck und über Ihren Jahrsbedarf.

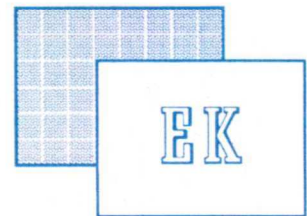

Estorfer Kunststoffbetrieb GmbH

**Lieferung in folgende Länder nur über unsere Auslandsvertretungen:
Please contact our business partners for deliveries to the following countries:**

Frankreich

Société DECMO
400, Rue Leon Gambetta
F-59044 Lille-Cedex
Tel.: +0328380840
Fax: +0328380850
E-mail: decmo@decmo.fr
www.decmo.com

Italien/Spanien

Dimatec S.P.A.
Via Galileo Galilei 7
I-22070 Guanzate (Co)
Tel.: +031.352.90.61
Fax: +031.352.90.97
E-mail: dimatec@dimatec.it
www.dimatec.it

Niederlande

JAC. VAN 't HART NEDERLAND B.V.
Dorp 92
3415 PH Polsbroek
Tel.: *31 (0) 182 308080
Fax: *31 (0) 182 309787
E-mail: info@hartnl.com
www.hartnl.eu

Großbritannien

Scan-Térieur Ltd.
30 The Metro Centre
Tolpits Lane, Watford
GB Herts. WD 18 9XG
Tel.: +0 19 23 / 80 03 53
Fax: +0 19 23 / 22 03 58

Japan

製造・輸入 総発売元

 **カーク産業株式会社**

CARAC INDUSTRY CO., LTD.

本 社：東京都練馬区平和台1-4-2
(〒179) ☎ 03 (3931) 0220代
FAX.03-3931-0706

E-mail: ana49218@nifty.com
www.carac.co.jp

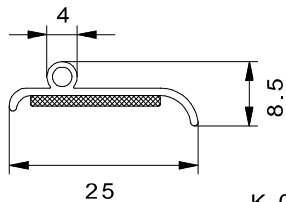
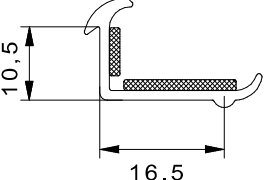
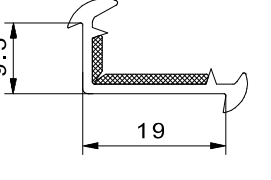
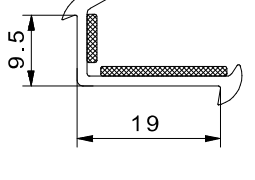
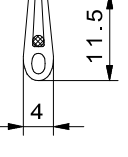
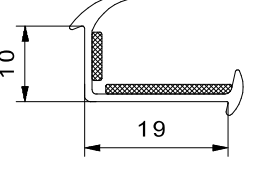
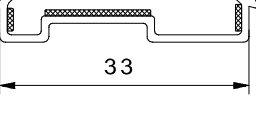
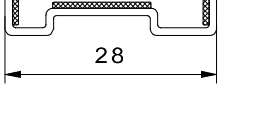
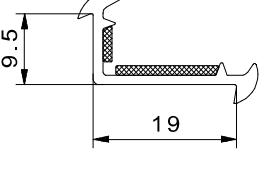
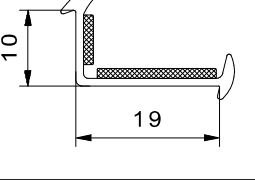
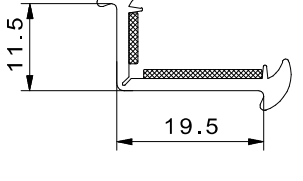
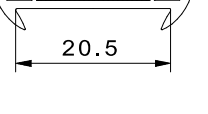

Wir beraten Sie gern:

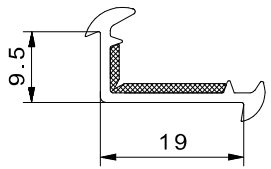
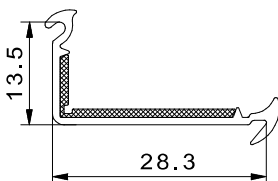
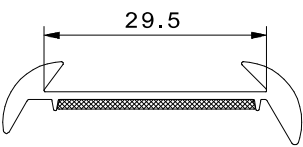
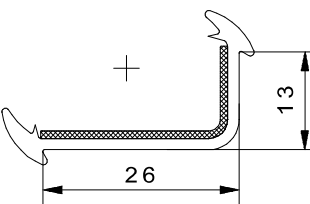
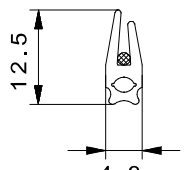
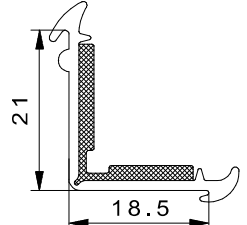
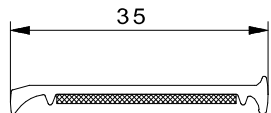
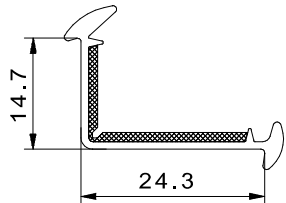
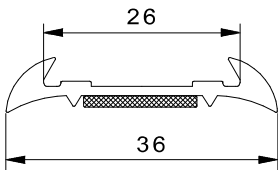

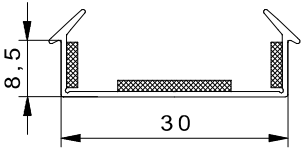
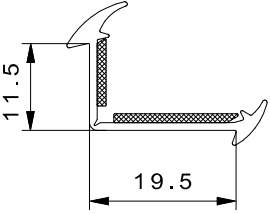
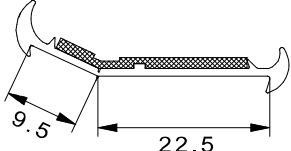
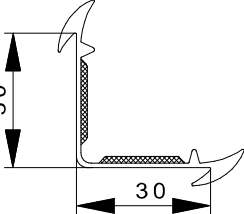
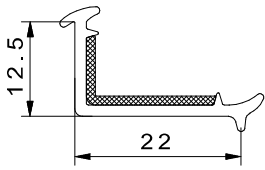
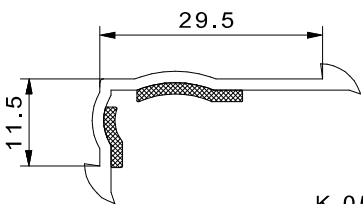
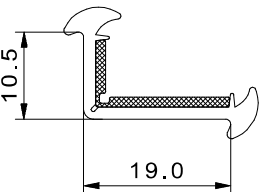
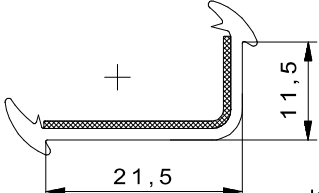
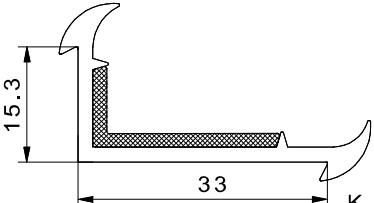
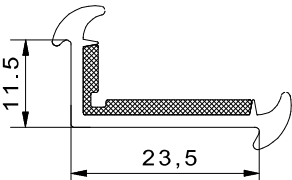
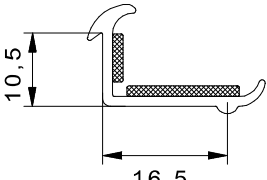
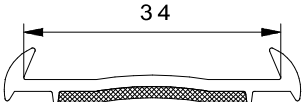
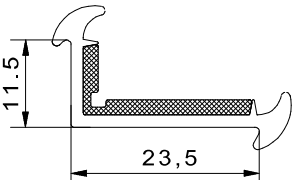
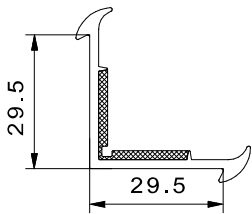
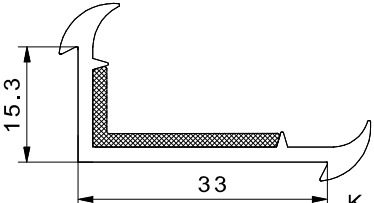
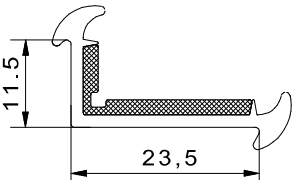
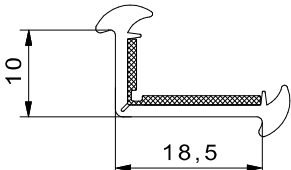
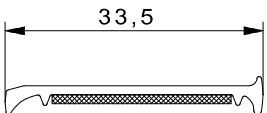
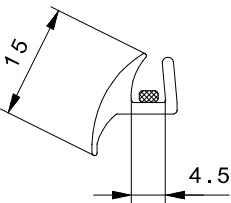
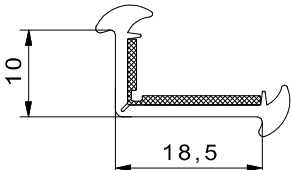
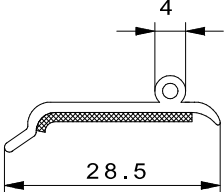

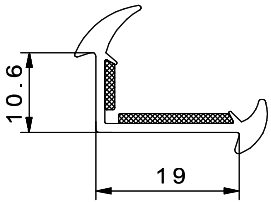
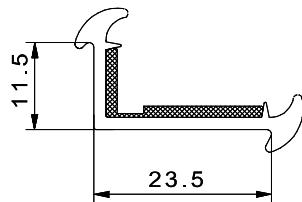
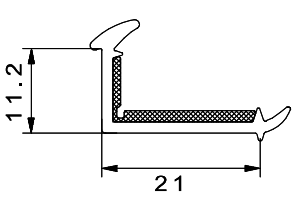
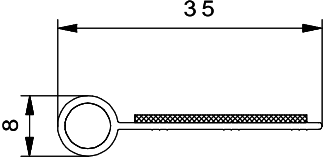
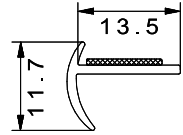
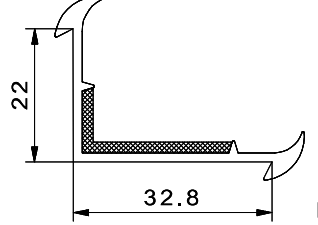
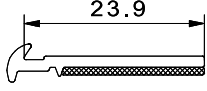
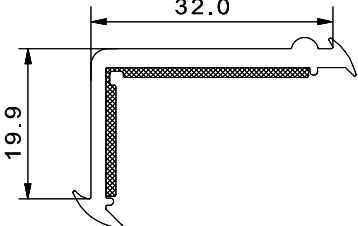
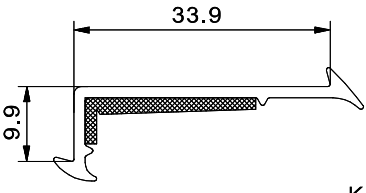
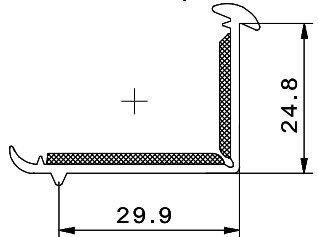
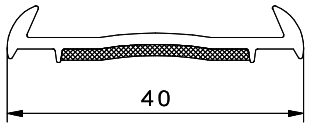
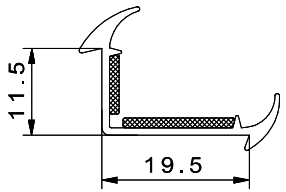
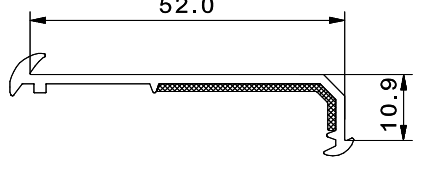
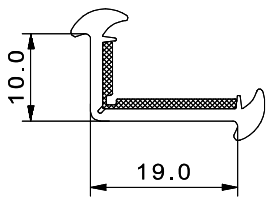
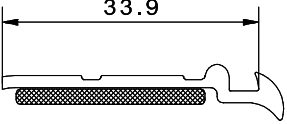
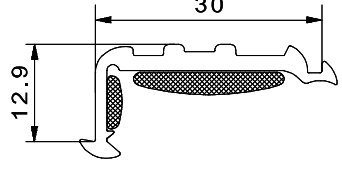
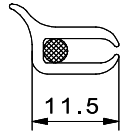
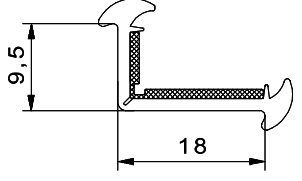
<p>Unterlegprofil</p>  <p>25 8.5 4</p> <p>K 001</p>	<p>Winkelprofil</p>  <p>10,5 16,5</p> <p>K 002</p>	<p>Winkelprofil</p>  <p>9,5 19</p> <p>K 003</p>
<p>Winkelprofil</p>  <p>9,5 19</p> <p>K 004</p>	<p>Kantendichtung</p>  <p>11,5 4</p> <p>K 005</p>	<p>Winkelprofil</p>  <p>10 19</p> <p>K 006</p>
<p>+</p> <p>K 007</p>	<p>Unterlegprofil</p>  <p>33</p> <p>K 008</p>	<p>Unterlegprofil</p>  <p>28</p> <p>K 009</p>
<p>Winkelprofil</p>  <p>9,5 19</p> <p>K 010</p>	<p>+</p> <p>+</p> <p>K 011</p>	<p>+</p> <p>K 012</p>
<p>Winkelprofil</p>  <p>10 19</p> <p>K 013</p>	<p>+</p> <p>K 014</p>	<p>+</p> <p>K 015</p>
<p>+</p> <p>K 016</p>	<p>+</p> <p>K 017</p>	<p>+</p> <p>K 018</p>
<p>Winkelprofil</p>  <p>11,5 19,5</p> <p>K 019</p>	<p>Unterlegprofil</p>  <p>20,5</p> <p>K 020</p>	<p>+</p> <p>K 021</p>

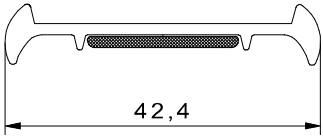
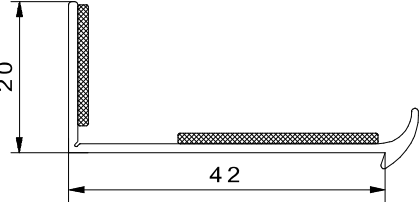
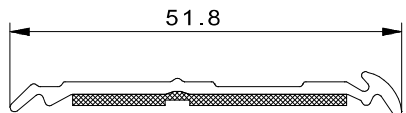
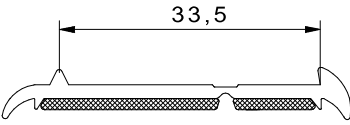
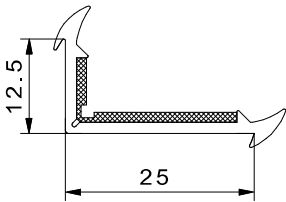
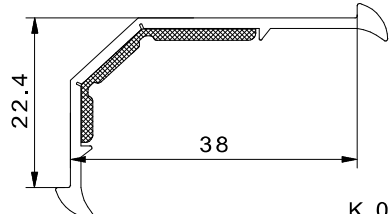
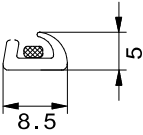
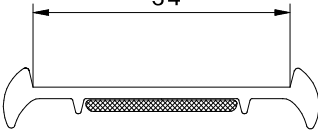
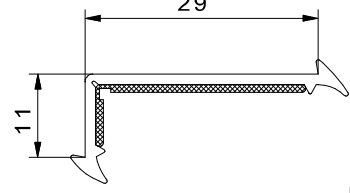
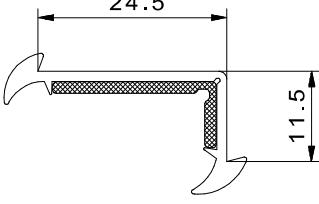
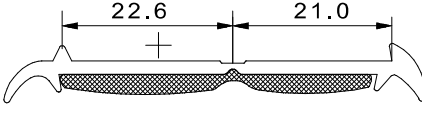
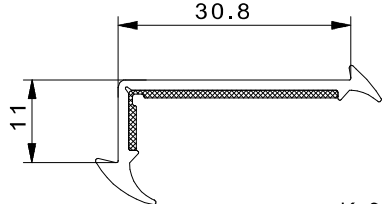
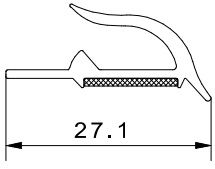
+	+	+
<p style="text-align: right;">K 022</p>	<p style="text-align: right;">K 023</p>	<p style="text-align: right;">K 024</p>
<p style="text-align: center;">Winkelprofil</p>  <p style="text-align: right;">K 025</p>	+	+
+	+	<p style="text-align: center;">Winkelprofil</p>  <p style="text-align: right;">K 030</p>
<p style="text-align: center;">Unterlegprofil</p>  <p style="text-align: right;">K 031</p>	<p style="text-align: center;">Winkelprofil</p>  <p style="text-align: right;">K 032</p>	<p style="text-align: center;">Kantenabdeckung</p>  <p style="text-align: right;">K 033</p>
<p style="text-align: center;">Winkelprofil</p>  <p style="text-align: right;">K 034</p>	+	+
<p style="text-align: center;">Winkelprofil</p>  <p style="text-align: right;">K 037</p>	+	<p style="text-align: center;">Winkelprofil</p>  <p style="text-align: right;">K 039</p>
+	<p style="text-align: center;">Unterlegprofil</p>  <p style="text-align: right;">K 041</p>	+
<p style="text-align: right;">K 040</p>	<p style="text-align: right;">K 042</p>	<p style="text-align: right;">K 042</p>

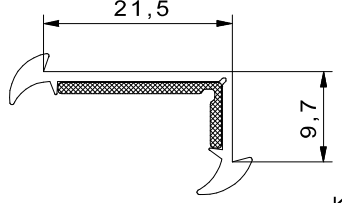
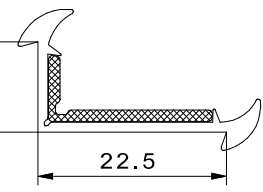
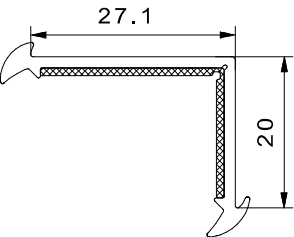
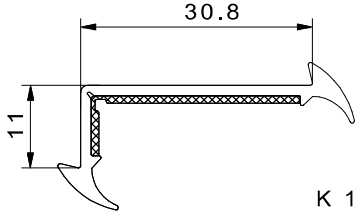
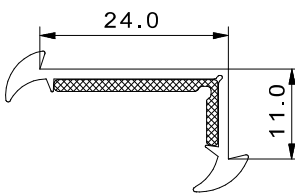
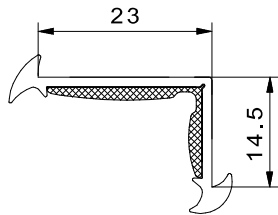
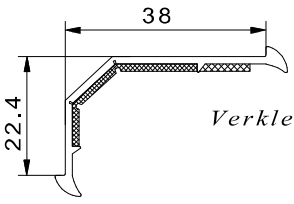
<p>Winkelprofil</p>  <p>K 043</p>	 <p>K 044</p>	<p>Winkelprofil</p>  <p>K 045</p>
<p>Winkelprofil</p>  <p>K 046</p>	<p>Winkelprofil</p>  <p>K 047</p>	 <p>K 048</p>
 <p>K 049</p>	<p>Winkelprofil</p>  <p>K 050</p>	<p>Winkelprofil</p>  <p>K 051</p>
 <p>K 052</p>	<p>Winkelprofil</p>  <p>K 053</p>	<p>Unterlegprofil</p>  <p>K 054</p>
<p>Winkelprofil</p>  <p>K 055</p>	<p>Winkelprofil</p>  <p>K 056</p>	<p>Winkelprofil</p>  <p>K 057</p>
<p>Winkelprofil</p>  <p>K 058</p>	<p>Winkelprofil</p>  <p>K 059</p>	<p>Unterlegprofil</p>  <p>K 060</p>
<p>Unterlegprofil</p>  <p>K 061</p>	<p>Winkelprofil</p>  <p>K 062</p>	<p>Unterlegprofil</p>  <p>K 063</p>

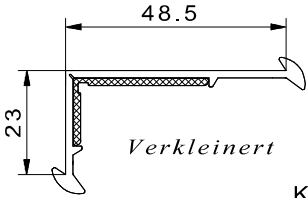
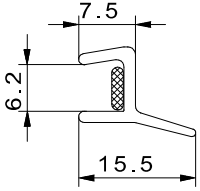
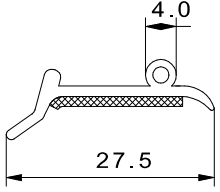
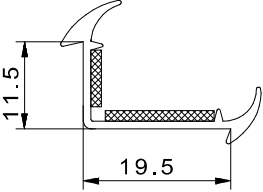
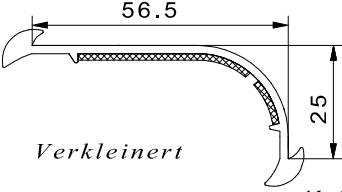
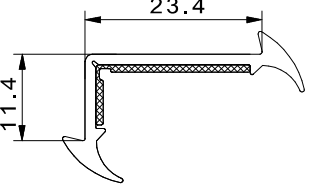
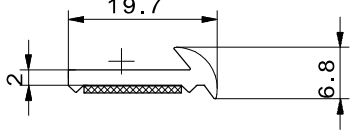
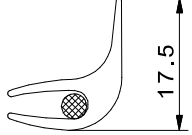
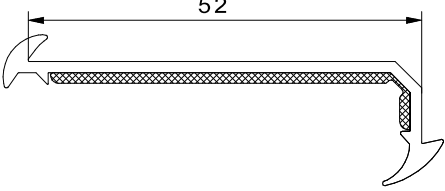
<p>Winkelprofil</p>  <p>K 064</p>	<p>Winkelprofil</p>  <p>K 065</p>	<p>Winkelprofil</p>  <p>K 066</p>
<p>Hohlbiege</p>  <p>K 067</p>	<p>Fugenabdeckprofil</p>  <p>K 068</p>	<p>Winkelprofil</p>  <p>K 069</p>
<p>Unterlegprofil</p>  <p>K 070</p>	<p>Winkelprofil</p>  <p>K 071</p>	<p>Winkelprofil</p>  <p>K 072</p>
<p>K 073</p>	<p>Winkelprofil</p>  <p>K 074</p>	<p>K 075</p>
<p>Unterlegprofil</p>  <p>K 076</p>	<p>Winkelprofil</p>  <p>K 077</p>	<p>Winkelprofil</p>  <p>K 078</p>
<p>Winkelprofil</p>  <p>K 079</p>	<p>Unterlegprofil</p>  <p>K 080</p>	<p>Winkelprofil</p>  <p>K 081</p>
<p>K 082</p>	<p>Kantenabdeckung</p>  <p>K 083</p>	<p>Winkelprofil</p>  <p>K 084</p>

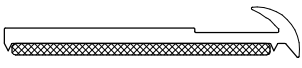
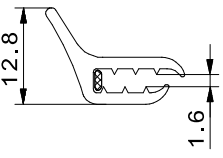
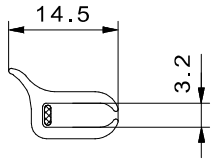
<p>Unterlegprofil</p>  <p>42,4</p> <p>K 085</p>	<p>Winkelprofil</p>  <p>20</p> <p>42</p> <p>K 086</p>	<p>Winkelprofil</p>  <p>51.8</p> <p>K 087</p>
<p>Winkelprofil</p>  <p>33,5</p> <p>K 088</p>	<p>Winkelprofil</p>  <p>12.5</p> <p>25</p> <p>K 089</p>	<p>Winkelprofil</p>  <p>22.4</p> <p>38</p> <p>K 090</p>
<p>Unterlegprofil</p>  <p>8.5</p> <p>5</p> <p>K 091</p>	<p>Unterlegprofil</p>  <p>34</p> <p>K 092</p>	<p>Winkelprofil</p>  <p>29</p> <p>11</p> <p>K 093</p>
<p>Winkelprofil</p>  <p>24.5</p> <p>11.5</p> <p>K 094</p>	<p>Winkelprofil</p>  <p>22.6</p> <p>21.0</p> <p>K 095</p>	<p>Winkelprofil</p>  <p>30.8</p> <p>11</p> <p>K 096</p>
<p>Abdeckprofil</p>  <p>27.1</p> <p>K 097</p>	 <p>K 098</p>	<p>Winkelprofil</p>  <p>21,5</p> <p>9,7</p> <p>K 099</p>
 <p>11.5</p> <p>22.5</p> <p>K 100</p>	 <p>27.1</p> <p>20</p> <p>K 101</p>	 <p>30.8</p> <p>11</p> <p>K 102</p>
 <p>24.0</p> <p>11.0</p> <p>K 103</p>	 <p>23</p> <p>14.5</p> <p>K 104</p>	 <p>38</p> <p>22.4</p> <p><i>Verkleinert</i></p> <p>K 105</p>

<p>Winkelprofil</p>  <p>K 106</p>	<p>+</p> <p>K 107</p>	<p>+</p> <p>K 108</p>
<p>+</p> <p>K 109</p>	<p>Kantenabdeckung</p>  <p>K 110</p>	<p>Unterlegprofil</p>  <p>K 111</p>
<p>Winkelprofil</p>  <p>K 112</p>	<p>Winkelprofil</p>  <p>K 113</p>	<p>Winkelprofil</p>  <p>K 114</p>
<p>+</p> <p>K 115</p>	<p>Unterlegprofil</p>  <p>K 116</p>	<p>Kantenabdeckung</p>  <p>K 117</p>
<p>+</p> <p>K 118</p>	<p>Winkelprofil</p>  <p>K 119</p>	<p>+</p> <p>K 120</p>
<p>Unterlegprofil</p>  <p>K 121</p>	<p>Unterlegprofil</p>  <p>K 122</p>	<p>Kantenabdeckung</p>  <p>K 123</p>
<p>Kantenabdeckung</p>  <p>K 124</p>	<p>+</p> <p>K 125</p>	<p>Unterlegprofil</p>  <p>K 126</p>

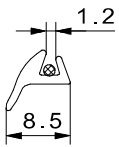
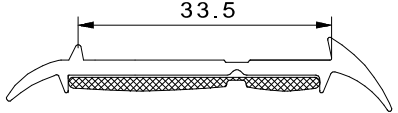
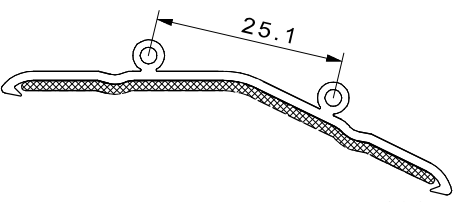
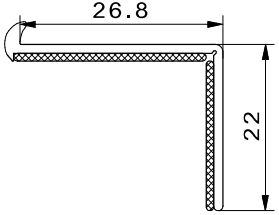
<p style="text-align: center;">+</p> <p style="text-align: right;">K 127</p>	<p style="text-align: center;">Unterlegprofil</p>  <p style="text-align: right;">K 128</p>	<p style="text-align: center;">Winkelprofil</p>  <p style="text-align: right;">K 129</p>
<p style="text-align: center;">Unterlegprofil</p>  <p style="text-align: right;">K 130</p>	<p style="text-align: center;">+</p> <p style="text-align: right;">K 131</p>	<p style="text-align: center;">+</p> <p style="text-align: right;">K 132</p>
<p style="text-align: center;">Winkelprofil</p>  <p style="text-align: right;">K 133</p>	<p style="text-align: center;">+</p> <p style="text-align: right;">K 134</p>	<p style="text-align: center;">+</p> <p style="text-align: right;">K 135</p>
<p style="text-align: center;">+</p> <p style="text-align: right;">K 136</p>	<p style="text-align: center;">+</p> <p style="text-align: center;">+</p> <p style="text-align: right;">K 137</p>	<p style="text-align: center;">+</p> <p style="text-align: right;">K 138</p>
<p style="text-align: center;">+</p> <p style="text-align: right;">K 139</p>	<p style="text-align: center;">+</p> <p style="text-align: right;">K 140</p>	<p style="text-align: center;">+</p> <p style="text-align: right;">K 141</p>
<p style="text-align: center;">+</p> <p style="text-align: right;">K 142</p>	<p style="text-align: center;">+</p> <p style="text-align: right;">K 143</p>	<p style="text-align: center;">+</p> <p style="text-align: right;">K 144</p>
<p style="text-align: center;">+</p> <p style="text-align: right;">K 145</p>	<p style="text-align: center;">+</p> <p style="text-align: right;">K 146</p>	<p style="text-align: center;">+</p> <p style="text-align: right;">K 147</p>

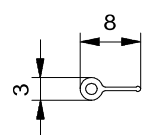
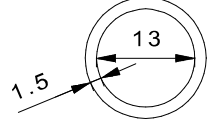
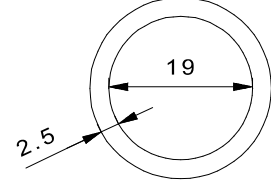
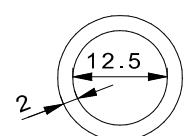
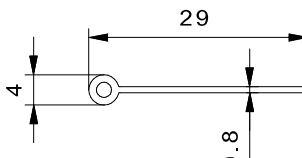
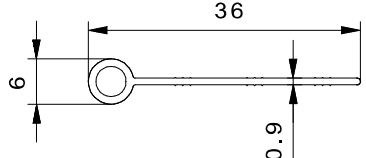
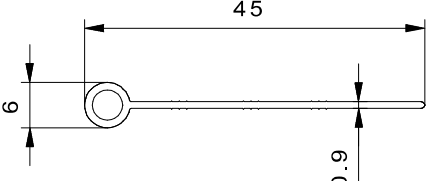
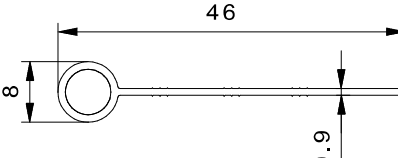
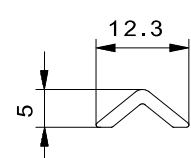
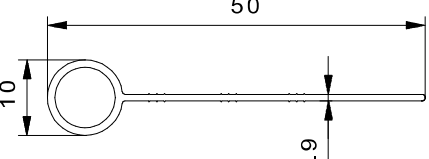
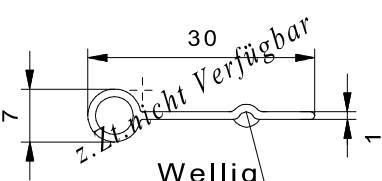
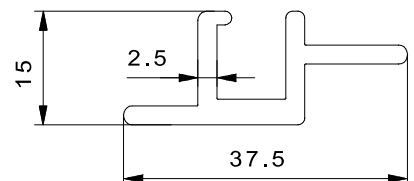
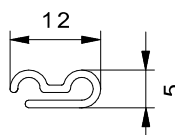
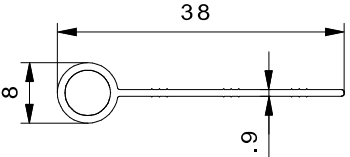
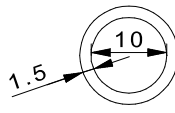
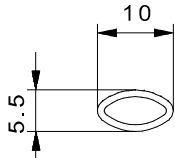
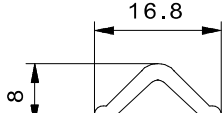
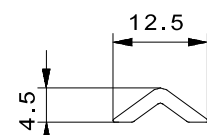
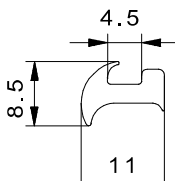
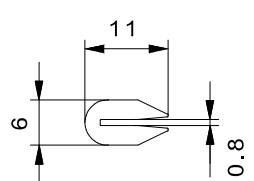
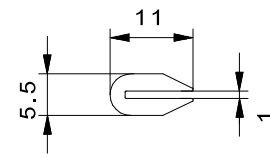
<p>Hohlbiege</p>  <p>E 101</p>	<p>Schlauch</p>  <p>E 102</p>	<p>Schlauch</p>  <p>E 103</p>
<p>Schlauch</p>  <p>E 104</p>	<p>Hohlbiege</p>  <p>E 105</p>	<p>Hohlbiege</p>  <p>E 106</p>
<p>Hohlbiege</p>  <p>E 107</p>	<p>Hohlbiege</p>  <p>E 108</p>	<p>Leistenfüller</p>  <p>E 109</p>
<p>Hohlbiege</p>  <p>E 110</p>	<p>Hohlbiege</p>  <p>E 111</p>	<p>Halteprofil</p>  <p>E 112</p>
<p>Kofferprofil</p>  <p>E 113</p>	<p>Hohlbiege</p>  <p>E 114</p>	<p>Schlauch</p>  <p>E 115</p>
<p>Griffschlauch</p>  <p>E 116</p>	<p>Leistenfüller</p>  <p>E 117</p>	<p>Leistenfüller</p>  <p>E 118</p>
<p>Unterlegprofil</p>  <p>E 119</p>	<p>Kantenschutz</p>  <p>E 120</p>	<p>Kantenschutz</p>  <p>E 121</p>

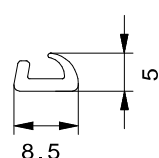
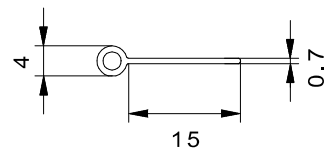
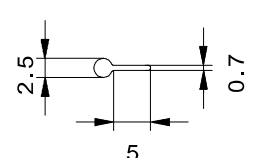
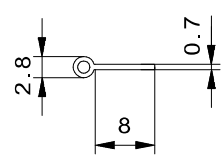
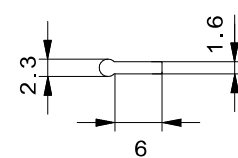
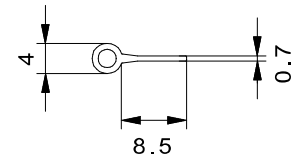
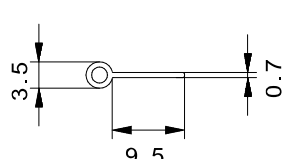
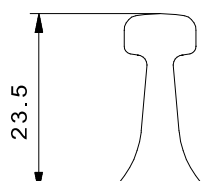
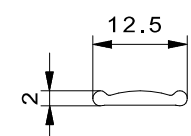
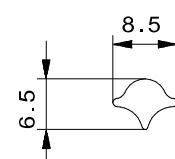
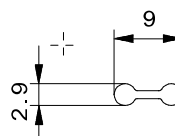
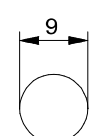
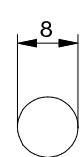
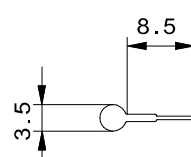
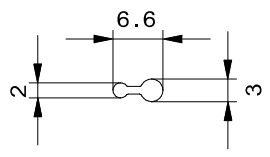
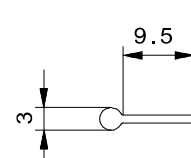
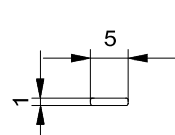
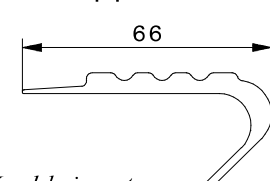
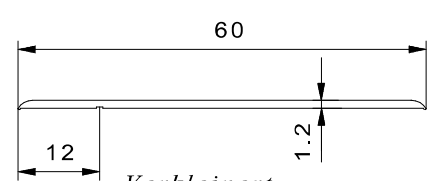
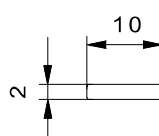
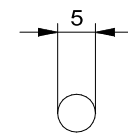
<p>Unterlegprofil</p>  <p>E 122</p>	<p>Hohlbiese</p>  <p>E 123</p>	<p>Biese</p>  <p>E 124</p>
<p>Hohlbiese</p>  <p>E 125</p>	<p>Biese</p>  <p>E 126</p>	<p>Hohlbiese</p>  <p>E 127</p>
<p>Hohlbiese</p>  <p>E 128</p>	<p>Fugenprofil</p>  <p>E 129</p>	<p>Griffband</p>  <p>E 130</p>
<p>Einreißfüller</p>  <p>E 131</p>	<p>Biese</p>  <p>E 132</p>	<p>Rundschnur</p>  <p>E 133</p>
<p>Rundschnur</p>  <p>E 134</p>	<p>Biese</p>  <p>E 135</p>	<p>Biese</p>  <p>E 136</p>
<p>Biese</p>  <p>E 137</p>	<p>Flachband</p>  <p>E 138</p>	<p>Treppenkante</p>  <p>E 139</p>
<p>Sockelleiste</p>  <p>E 140</p>	<p>Flachband</p>  <p>E 141</p>	<p>Rundschnur</p>  <p>E 142</p>

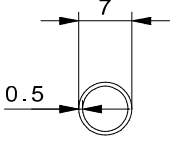
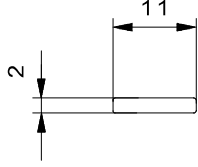
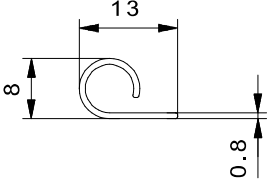
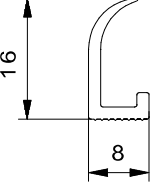
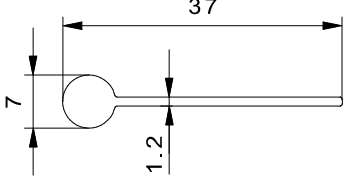
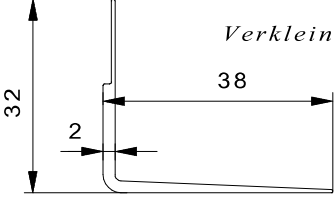
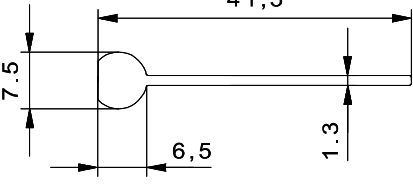
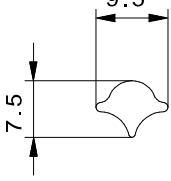
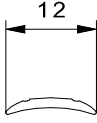
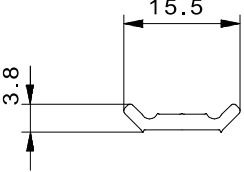
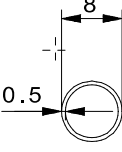
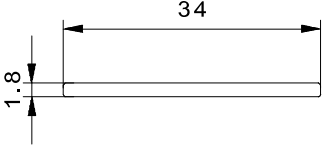
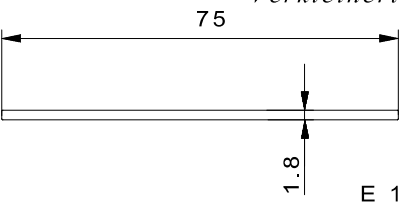
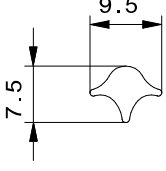
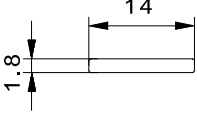
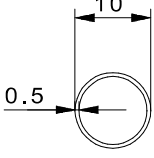
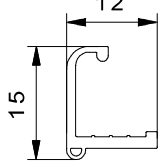
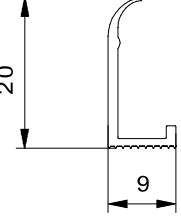
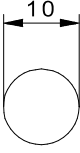
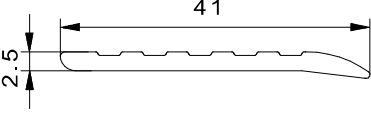
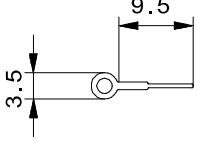
<p>Schlauch</p>  <p>E 143</p>	<p>Flachband</p>  <p>E 144</p>	<p>Kantenschutz</p>  <p>E 145</p>
<p>Sonderprofil</p>  <p>E 146</p>	<p>Keder</p>  <p>E 147</p>	<p>Treppenkante</p>  <p>E 148</p>
<p>Keder</p>  <p>E 149</p>	<p>Einreißfüller</p>  <p>E 150</p>	<p>Leistenfüller</p>  <p>E 151</p>
<p>Leistenfüller</p>  <p>E 152</p>	<p>Schlauch</p>  <p>E 153</p>	<p>Flachband</p>  <p>E 154</p>
<p>Flachband</p>  <p>E 155</p>	<p>Einreißfüller</p>  <p>E 156</p>	<p>Flachband</p>  <p>E 157</p>
<p>Schlauch</p>  <p>E 158</p>	<p>Sonderprofil</p>  <p>E 159</p>	<p>Sonderprofil</p>  <p>E 160</p>
<p>Rundschnur</p>  <p>E 161</p>	<p>Treppenkante</p>  <p>E 162</p>	<p>Hohlbiege</p>  <p>E 163</p>

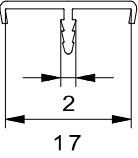
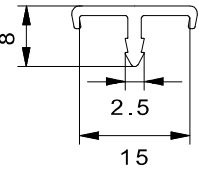
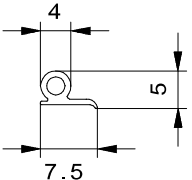
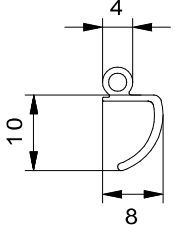
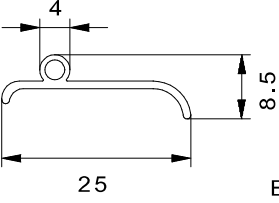
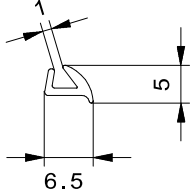
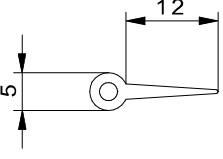
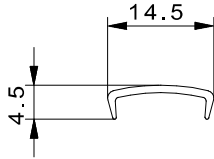
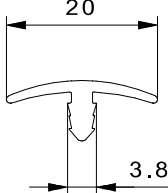
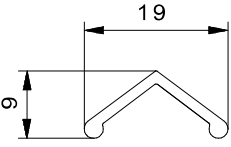
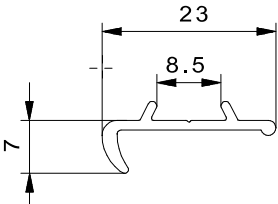
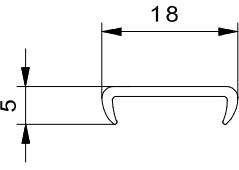
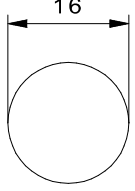
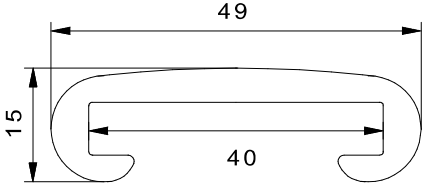
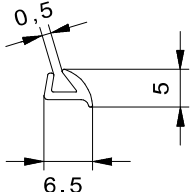
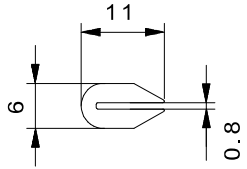
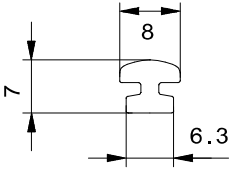
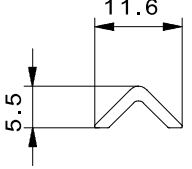
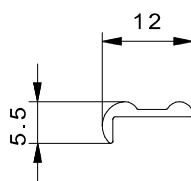
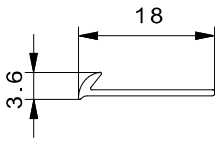
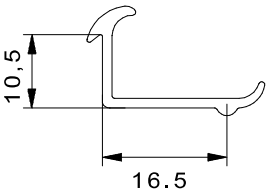
<p>Stegumleimer</p>  <p>E 164</p>	<p>Stegumleimer</p>  <p>E 165</p>	<p>Unterlegprofil</p>  <p>E 166</p>
<p>Unterlegprofil</p>  <p>E 167</p>	<p>Unterlegprofil</p>  <p>E 168</p>	<p>Unterlegprofil</p>  <p>E 169</p>
<p>Hohlbiege</p>  <p>E 170</p>	<p>Kantenschutz</p>  <p>E 171</p>	<p>Stegumleimer</p>  <p>E 172</p>
<p>Sonderprofil</p>  <p>E 173</p>	<p>Abdeckprofil</p>  <p>E 174</p>	<p>Kantenschutz</p>  <p>E 175</p>
<p>Rundschnur</p>  <p>E 176</p>	<p>Handlauf</p>  <p>E 177</p>	<p>Unterlegprofil</p>  <p>E 178</p>
<p>Kantenschutz</p>  <p>E 179</p>	<p>Fugenprofil</p>  <p>E 180</p>	<p>Leistenfüller</p>  <p>E 181</p>
<p>Abdeckprofil</p>  <p>E 182</p>	<p>Unterlegprofil</p>  <p>E 183</p>	<p>Winkelprofil</p>  <p>E 184</p>

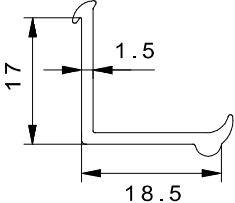
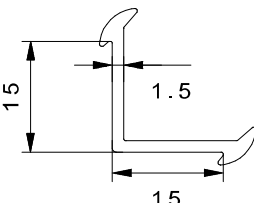
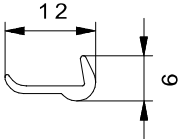
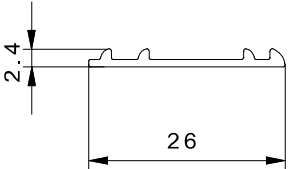
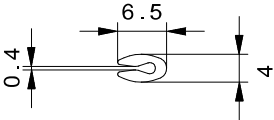
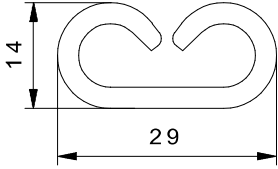
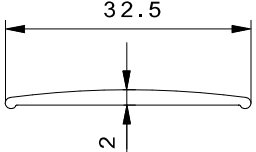
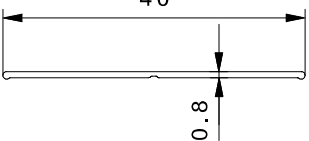
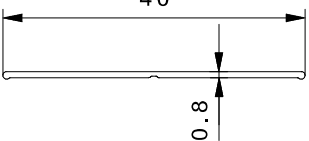
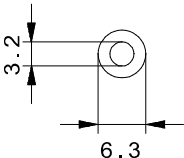
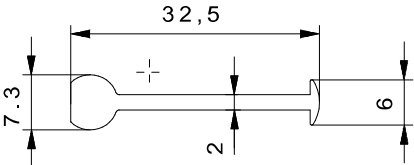
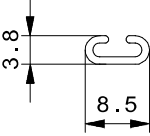
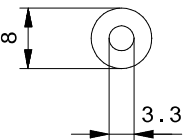
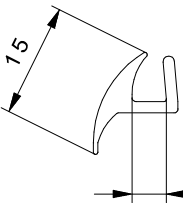
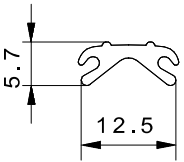
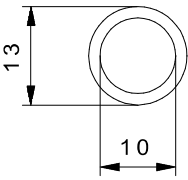
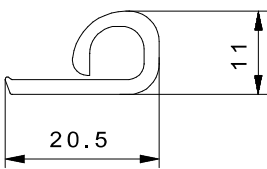
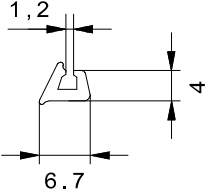
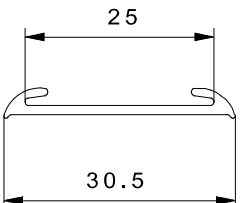
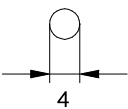
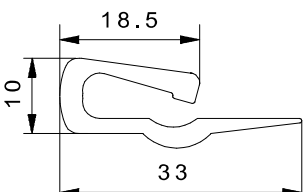

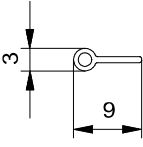
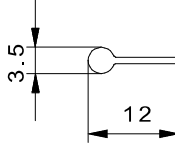
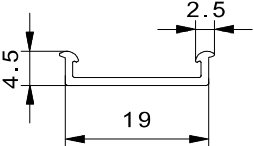
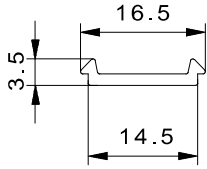
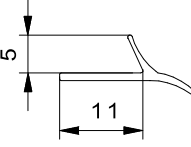
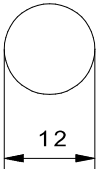
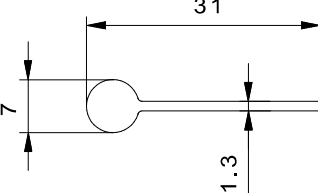
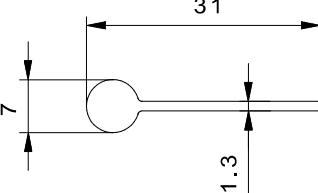
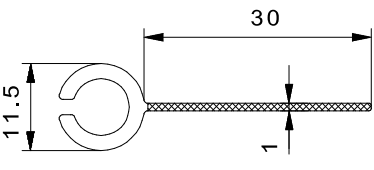
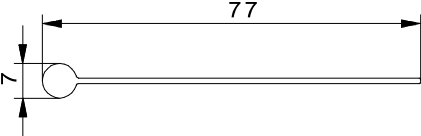
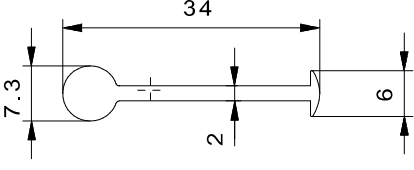
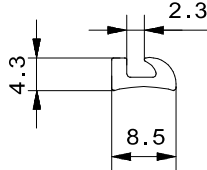
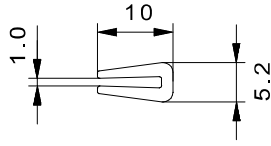
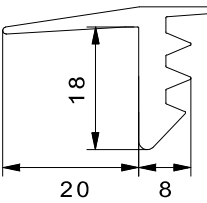
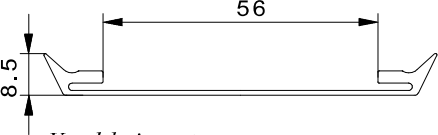
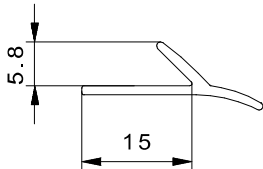
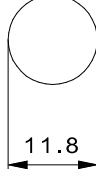
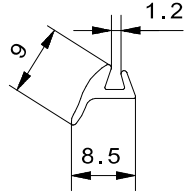
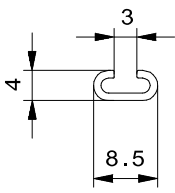
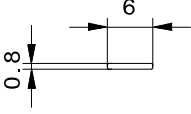
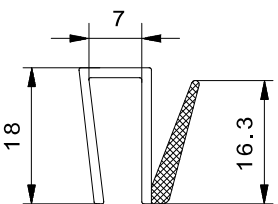
<p>Winkelprofil</p>  <p>E 185</p>	<p>Winkelprofil</p>  <p>E 186</p>	<p>Abdeckprofil</p>  <p>E 187</p>
<p>Sonderprofil</p>  <p>E 188</p>	<p>Kantenschutz</p>  <p>E 189</p>	<p>Kantenschutz</p>  <p>E 190</p>
<p>Abdeckprofil</p>  <p>E 191</p>	<p>Abdeckprofil</p>  <p>E 192</p>	<p>Sockelleiste</p>  <p>E 193</p>
<p>Schlauch</p>  <p>E 194</p>	<p>Keder</p>  <p>E 195</p>	<p>Abdeckprofil</p>  <p>E 196</p>
<p>Schlauch</p>  <p>E 197</p>	<p>Unterlegprofil</p>  <p>E 198</p>	<p>Leistenfüller</p>  <p>E 199</p>
<p>Schlauch</p>  <p>E 200</p>	<p>Kantenschutz</p>  <p>E 201</p>	<p>Unterlegprofil</p>  <p>E 202</p>
<p>Unterlegprofil</p>  <p>E 203</p>	<p>Rundschnur</p>  <p>E 204</p>	<p>Kantenschutz</p>  <p>E 205</p>

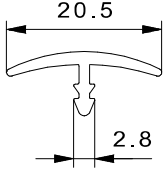
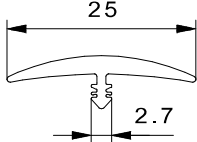
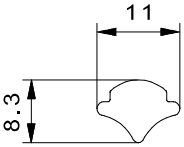
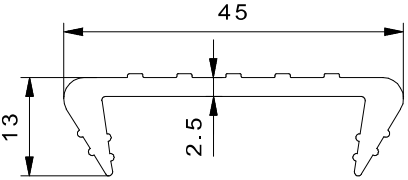
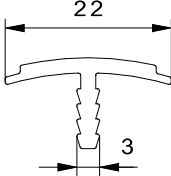
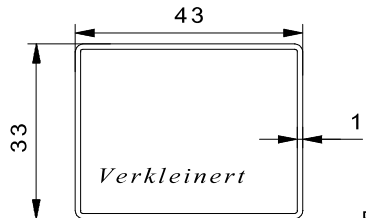
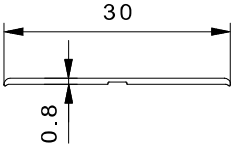
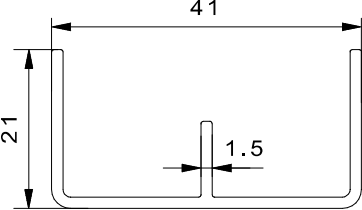
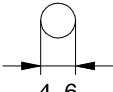
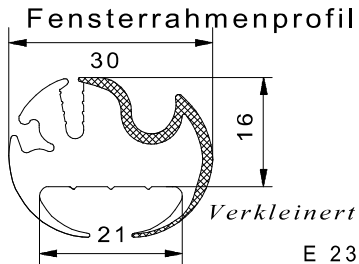
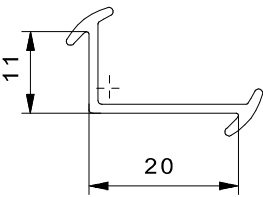
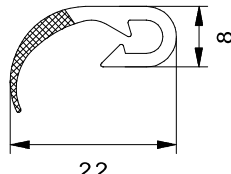
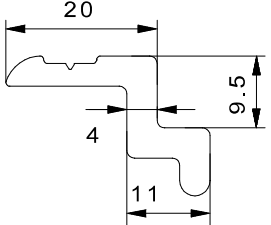
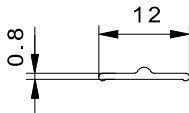
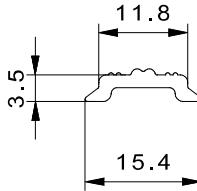
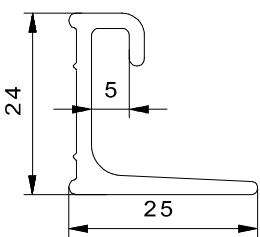
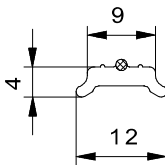
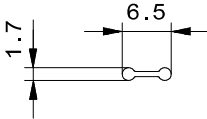
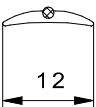
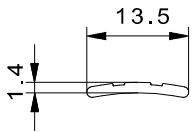
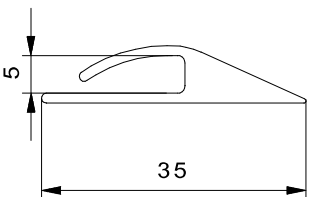
<p>Hohlbiese</p>  <p>E 206</p>	<p>Biese</p>  <p>E 207</p>	<p>Unterlegprofil</p>  <p>E 208</p>
<p>Unterlegprofil</p>  <p>E 209</p>	<p>Y-Profil</p>  <p>E 210</p>	<p>Rundschnur</p>  <p>E 211</p>
<p>Keder</p>  <p>E 212</p>	<p>Keder</p>  <p>E 213</p>	<p>Keder</p>  <p>E 214</p>
<p>Keder</p>  <p><i>Verkleinert</i></p> <p>E 215</p>	<p>Keder</p>  <p>E 216</p>	<p>Unterlegprofil</p>  <p>E 217</p>
<p>Kantenschutz</p>  <p>E 218</p>	<p>Sonderprofil</p>  <p>E 219</p>	<p>Abdeckprofil</p>  <p><i>Verkleinert</i></p> <p>E 220</p>
<p>Y-Profil</p>  <p>E 221</p>	<p>Rundschnur</p>  <p>E 222</p>	<p>Unterlegprofil</p>  <p>E 223</p>
<p>Abdeckprofil</p>  <p>E 224</p>	<p>Flachband</p>  <p>E 225</p>	<p>Sonderprofil</p>  <p>E 226</p>

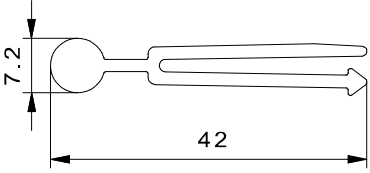
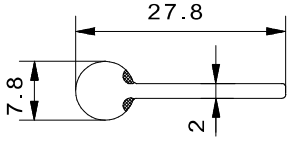
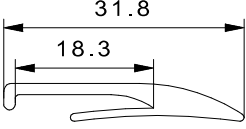
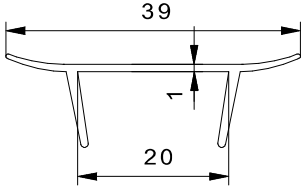
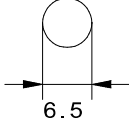
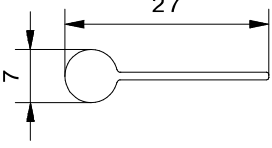
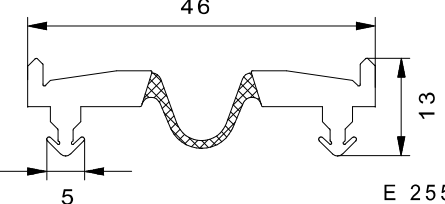
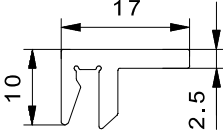
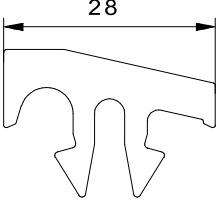
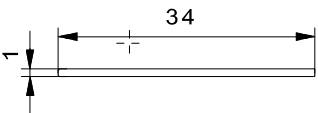
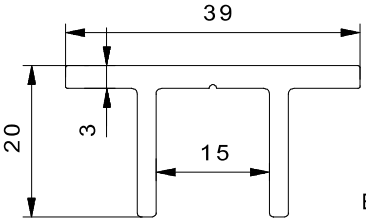
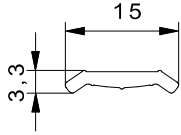
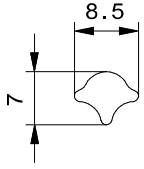
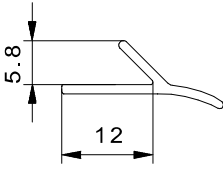
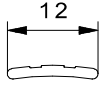
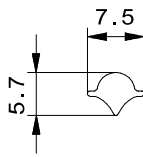
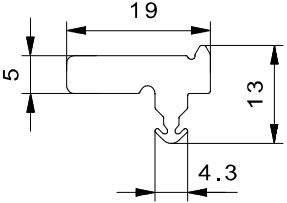
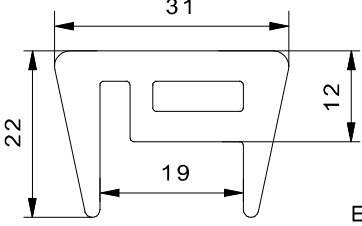
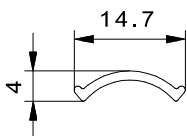

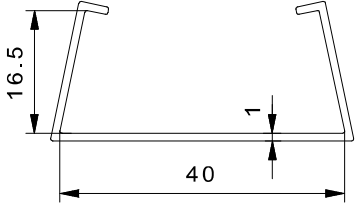
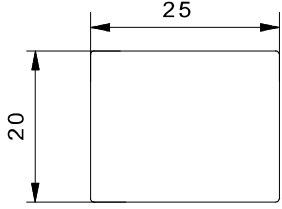
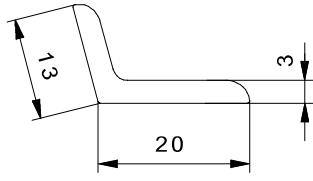
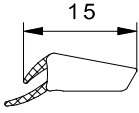
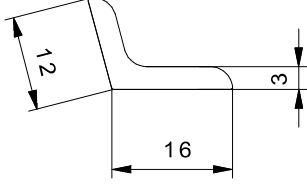
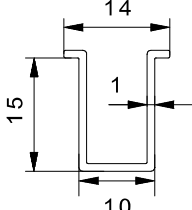
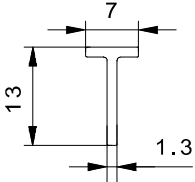
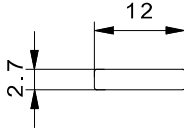
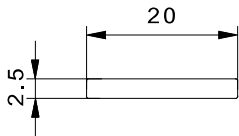
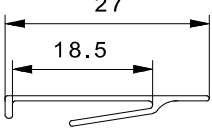
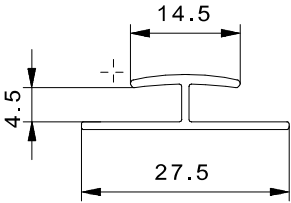
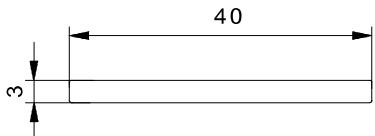
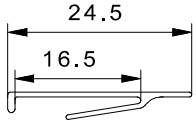
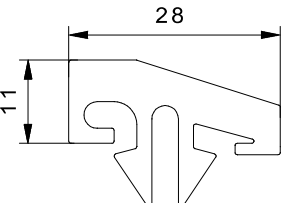
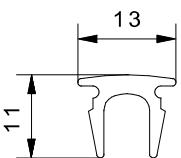
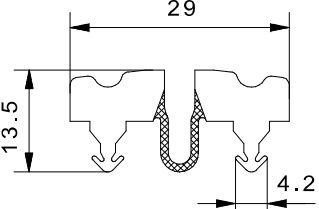
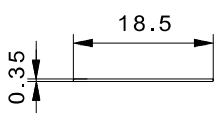
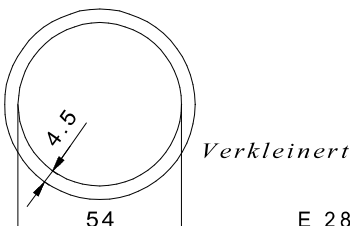
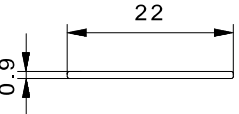
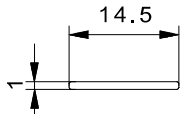
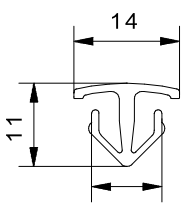

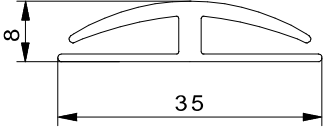
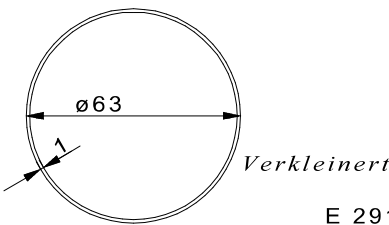
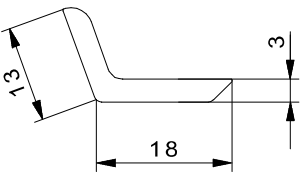
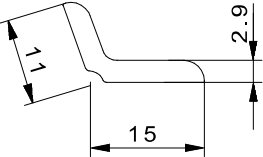
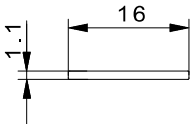
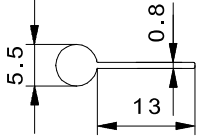
<p>Stegumleimer</p>  <p>E 227</p>	<p>Stegumleimer</p>  <p>E 228</p>	<p>Einreißfüller</p>  <p>E 229</p>
<p>Sonderprofil</p>  <p>E 230</p>	<p>Stegumleimer</p>  <p>E 231</p>	<p>Vierkantrohr</p>  <p>E 232</p>
<p>Sockelleiste</p>  <p>E 233</p>	<p>Sonderprofil</p>  <p>E 234</p>	<p>Rundschnur</p>  <p>E 235</p>
<p>Fensterrahmenprofil</p>  <p>E 236</p>	<p>Winkelprofil</p>  <p>E 237</p>	<p>Sonderprofil</p>  <p>E 238</p>
<p>Sonderprofil</p>  <p>E 239</p>	<p>Leistenfüller</p>  <p>E 240</p>	<p>Leistenfüller</p>  <p>E 241</p>
<p>Sonderprofil</p>  <p>E 242</p>	<p>Leistenfüller</p>  <p>E 243</p>	<p>Biese</p>  <p>E 244</p>
<p>Leistenfüller</p>  <p>E 245</p>	<p>Leistenfüller</p>  <p>E 246</p>	<p>Verbindungsprofil</p>  <p>E 247</p>

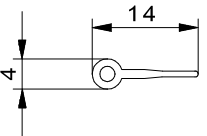
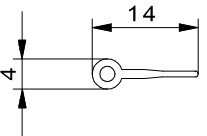
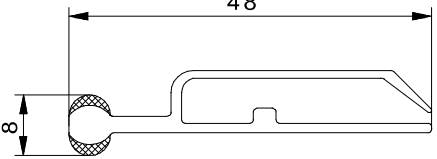
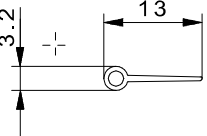
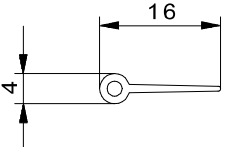
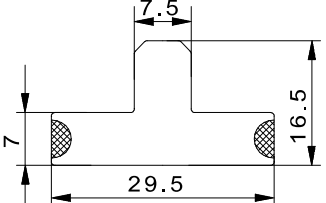
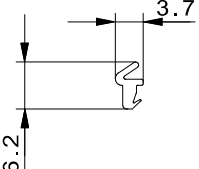
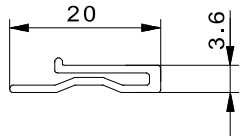
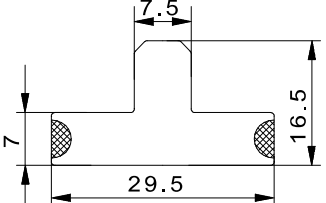
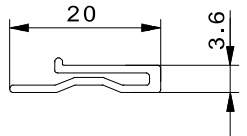
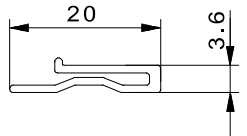
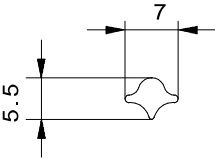
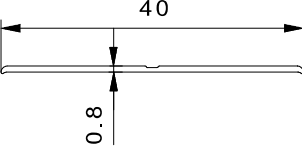
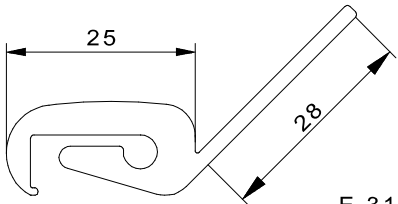
<p>Keder</p>  <p>E 248</p>	<p>Keder</p>  <p>E 249</p>	<p>E 250</p>
<p>Sonderprofil</p>  <p>E 251</p>	<p>Sonderprofil</p>  <p>E 252</p>	<p>Rundschnur</p>  <p>E 253</p>
<p>Keder</p>  <p>E 254</p>	<p>Sonderprofil</p>  <p>E 255</p>	<p>Sonderprofil</p>  <p>E 256</p>
<p>Sonderprofil</p>  <p>E 257</p>	<p>Flachband</p>  <p>E 258</p>	<p>Sonderprofil</p>  <p>E 259</p>
<p>E 260</p>	<p>Leistenfüller</p>  <p>E 261</p>	<p>Einreißfüller</p>  <p>E 262</p>
<p>Y-Profil</p>  <p>E 263</p>	<p>Leistenfüller</p>  <p>E 264</p>	<p>Einreißfüller</p>  <p>E 265</p>
<p>Sonderprofil</p>  <p>E 266</p>	<p>Sonderprofil</p>  <p>E 267</p>	<p>Leistenfüller</p>  <p>E 268</p>

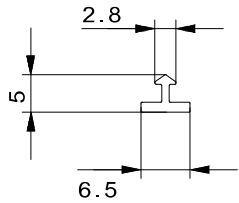
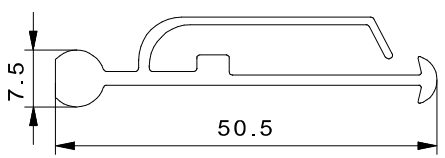
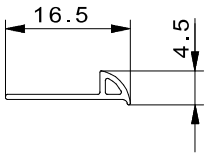
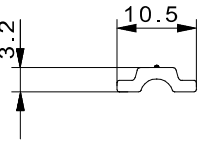
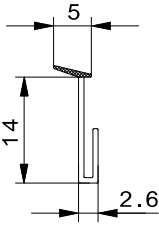
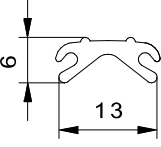
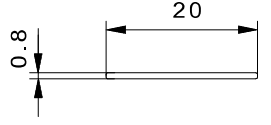
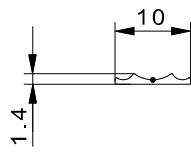
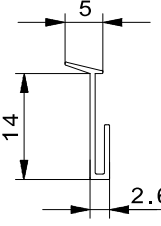
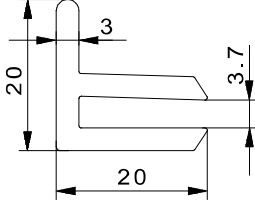
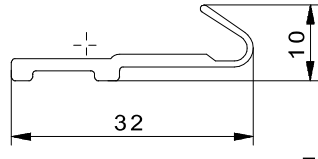
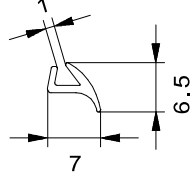
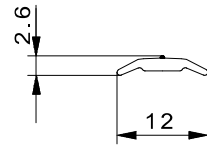
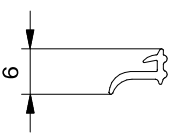
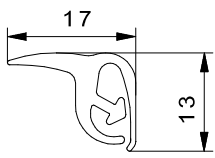
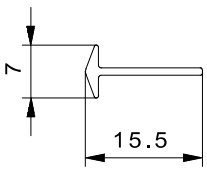
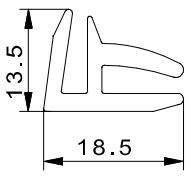
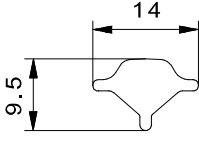
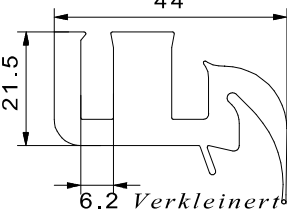
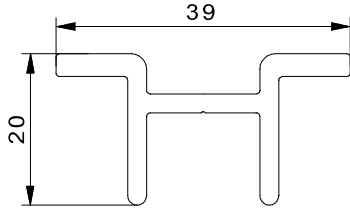
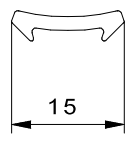
<p>Sonderprofil</p>  <p>E 269</p>	<p>Vierkantprofil</p>  <p>E 270</p>	<p>Sonderprofil</p>  <p>E 271</p>
<p>Sonderprofil</p>  <p>E 272</p>	<p>Sonderprofil</p>  <p>E 273</p>	<p>Sonderprofil</p>  <p>E 274</p>
<p>Sonderprofil</p>  <p>E 275</p>	<p>Flachband</p>  <p>E 276</p>	<p>Flachband</p>  <p>E 277</p>
<p>Sonderprofil</p>  <p>E 278</p>	<p>Plattenverbinder</p>  <p>E 279</p>	<p>Flachband</p>  <p>E 280</p>
<p>Sonderprofil</p>  <p>E 281</p>	<p>Sonderprofil</p>  <p>E 282</p>	<p>Sonderprofil</p>  <p>E 283</p>
<p>Sonderprofil</p>  <p>E 284</p>	<p>Flachband</p>  <p>E 285</p>	<p>Schlauch</p>  <p>E 286</p>
<p>Flachband</p>  <p>E 287</p>	<p>Flachband</p>  <p>E 288</p>	<p>Sonderprofil</p>  <p>E 289</p>

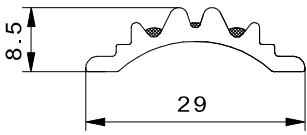

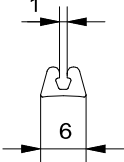
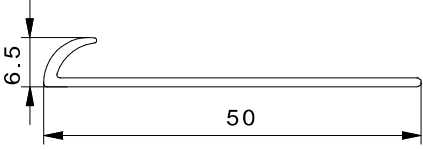
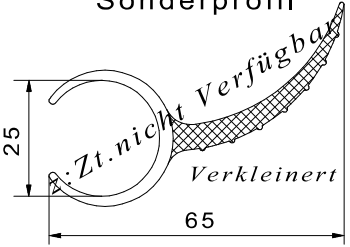
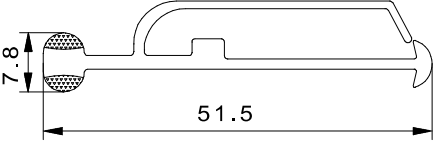
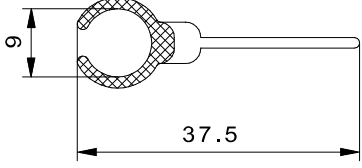
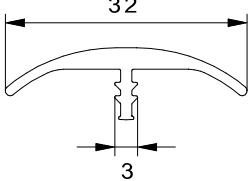
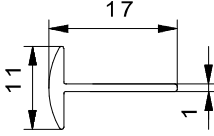
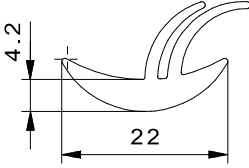
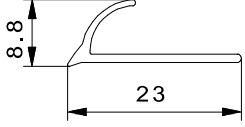
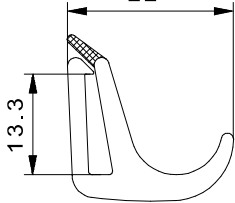

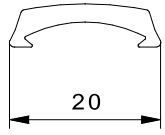
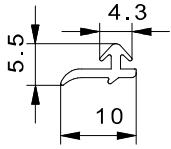
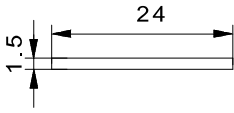
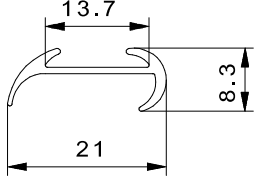
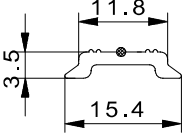
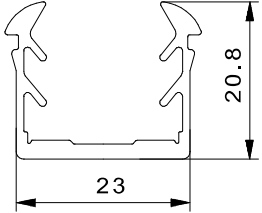
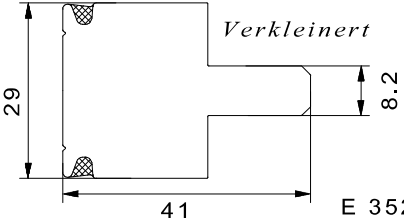
<p>Übergangsprofil</p>  <p>E 290</p>	<p>Schlauch</p>  <p>E 291</p>	<p>Sonderprofil</p>  <p>E 292</p>
<p>Sonderprofil</p>  <p>E 293</p>	<p>Flachband</p>  <p>E 294</p>	<p>Keder</p>  <p>E 295</p>
<p>Flachband</p>  <p>E 296</p>	<p>Flachband</p>  <p>E 297</p>	<p>Hohlbiege</p>  <p>E 298</p>
<p>Keder</p>  <p>E 299</p>	<p>Hohlbiege</p>  <p>E 300</p>	<p>Hohlbiege</p>  <p>E 301</p>
<p>Sonderprofil</p>  <p>E 302</p>	<p>Eindrückdichtung</p>  <p>E 303</p>	<p>Sonderprofil</p>  <p>E 304</p>
<p>Sonderprofil</p>  <p>E 305</p>	<p>Sonderprofil</p>  <p>E 306</p>	<p>Sonderprofil</p>  <p>E 307</p>
<p>Einreißfüller</p>  <p>E 308</p>	<p>Sockelleiste</p>  <p>E 309</p>	<p>Einhängekeder</p>  <p>E 310</p>

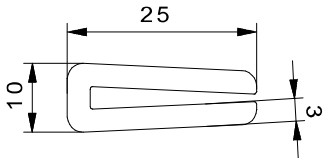
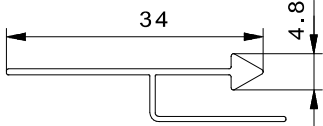
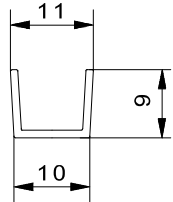
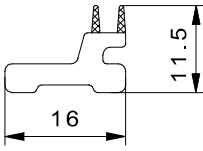
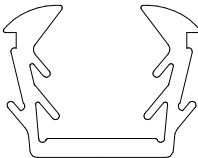
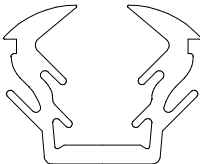
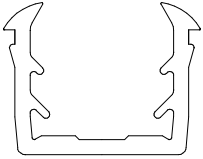
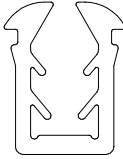
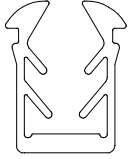
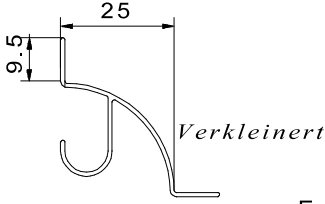
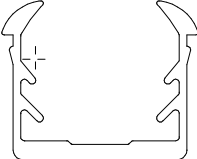
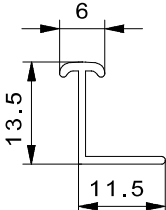
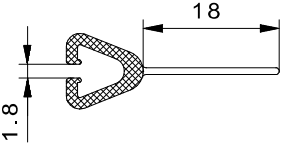
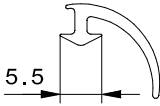
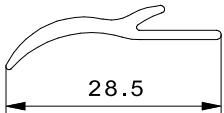
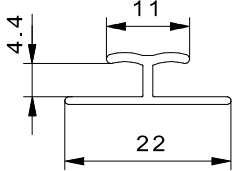
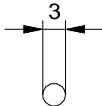
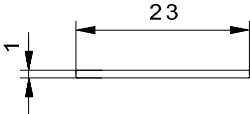
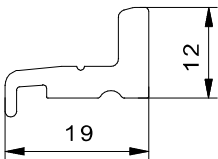
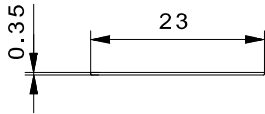

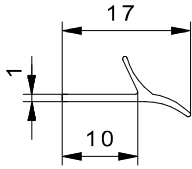
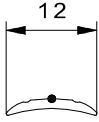
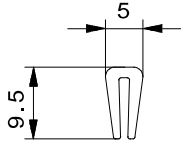
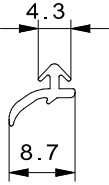
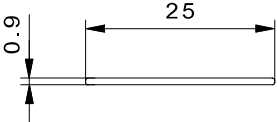

<p>Sonderprofil</p>  <p>E 311</p>	<p>Keder</p>  <p>E 312</p>	<p>Hohlbiege</p>  <p>E 313</p>
<p>Leistenfüller</p>  <p>E 314</p>	<p>Kantenschutz</p>  <p>E 315</p>	<p>Leistenfüller</p>  <p>E 316</p>
<p>Flachband</p>  <p>E 317</p>	<p>Leistenfüller</p>  <p>E 318</p>	<p>Kantenschutz</p>  <p>E 319</p>
<p>Schubfachleiste</p>  <p>E 320</p>	<p>Sonderprofil</p>  <p>E 321</p>	<p>Unterlegprofil</p>  <p>E 322</p>
<p>Leistenfüller</p>  <p>E 323</p>	<p>Unterlegprofil</p>  <p>E 324</p>	<p>Sonderprofil</p>  <p>E 325</p>
<p>Abdeckprofil</p>  <p>E 326</p>	<p>Übergangsprofil</p>  <p>E 327</p>	<p>Einreißfüller</p>  <p>E 328</p>
<p>Sonderprofil</p>  <p>E 329</p>	<p>Sonderprofil</p>  <p>E 330</p>	<p>Leistenfüller</p>  <p>E 331</p>

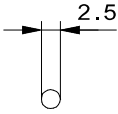
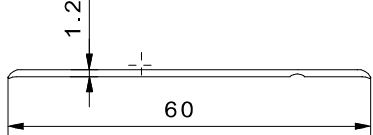
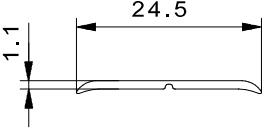
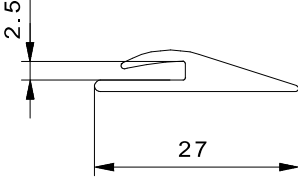
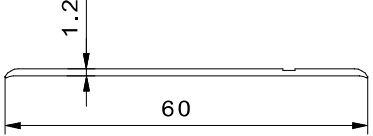

	<p>Leistenfüller</p>  <p>E 332</p>	<p>Leistenfüller</p>  <p>E 333</p>	E 334
<p>Unterlegprofil</p>  <p>E 335</p>	<p>Sonderprofil</p>  <p>E 336</p>	<p>Sonderprofil</p>  <p>E 337</p>	E 337
<p>Keder</p>  <p>E 338</p>	<p>Keder</p>  <p>E 339</p>	<p>Stegumleimer</p>  <p>E 340</p>	E 340
<p>Abdeckprofil</p>  <p>E 341</p>	<p>Türdichtprofil</p>  <p>E 342</p>	<p>Y-Profil</p>  <p>E 343</p>	E 343
<p>Regenrinne</p>  <p>E 344</p>	<p>Rundschnur</p>  <p>E 345</p>	<p>Leistenfüller</p>  <p>E 346</p>	E 346
<p>Unterlegprofil</p>  <p>E 347</p>	<p>Flachband</p>  <p>E 348</p>	<p>Unterlegprofil</p>  <p>E 349</p>	E 349
<p>Leistenfüller</p>  <p>E 350</p>	<p>Scheibeneinfaßprofil</p>  <p>E 351</p>	<p>Sonderprofil</p>  <p>E 352</p>	E 352

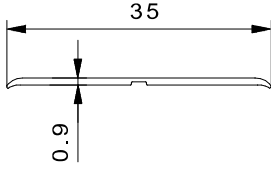
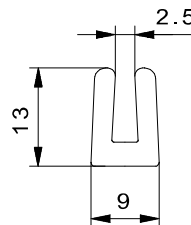
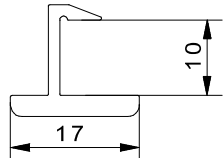
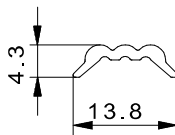
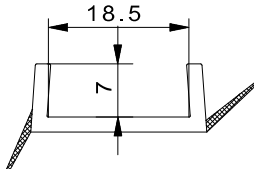
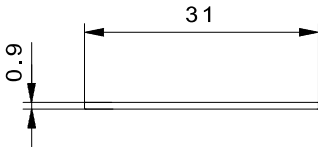
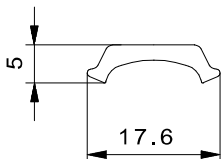

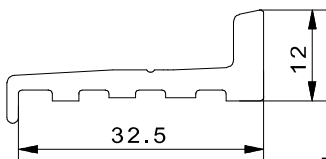
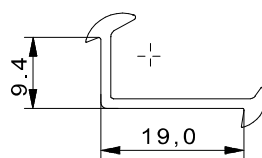
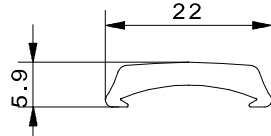
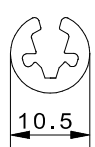
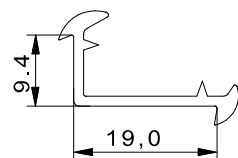
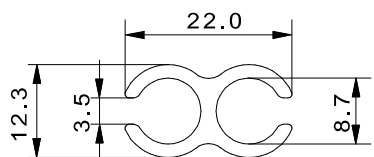
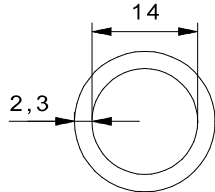
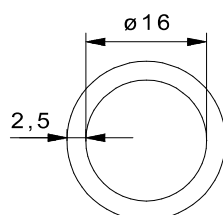
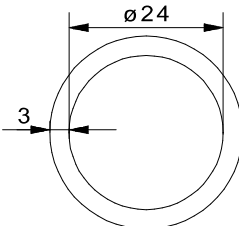
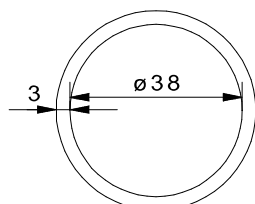
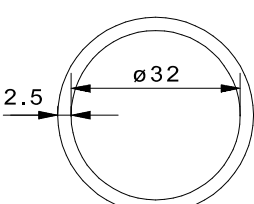



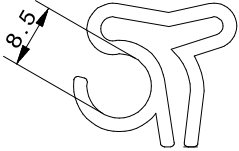

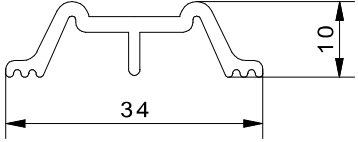
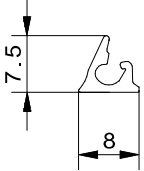
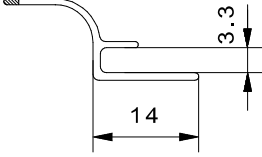
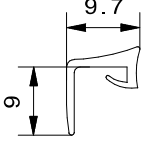
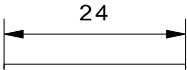
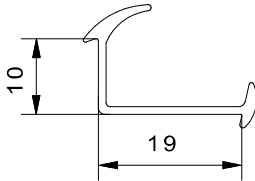
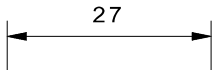
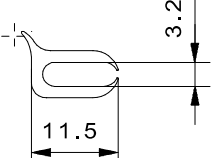
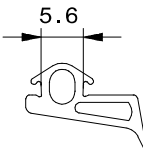
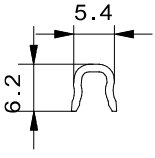
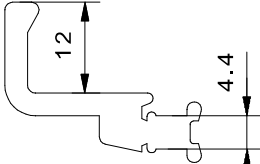
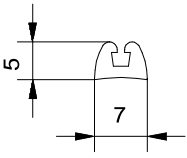
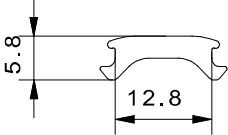
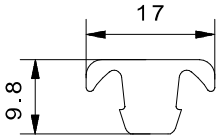
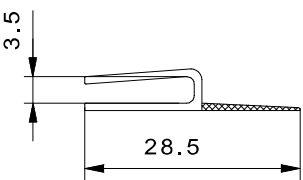
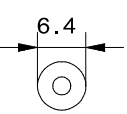
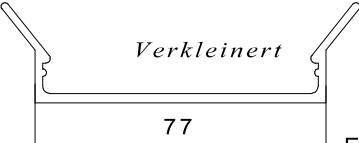
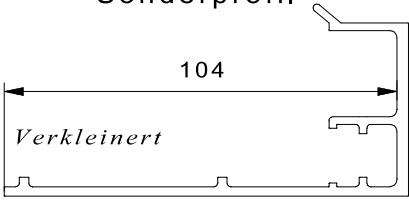
<p>Kantenschutz</p>  <p>E 353</p>	<p>Keder</p>  <p>E 354</p>	<p>U-Profil</p>  <p>E 355</p>
<p>Sonderprofil</p>  <p>E 356</p>	<p>Scheibeneinfassprofil</p>  <p>E 357</p>	<p>Scheibeneinfassprofil</p>  <p>E 358</p>
<p>Scheibeneinfassprofil</p>  <p>E 359</p>	<p>Scheibeneinfassprofil</p>  <p>E 360</p>	<p>Scheibeneinfassprofil</p>  <p>E 361</p>
<p>Kabelkanal</p>  <p>E 362</p>	<p>Scheibeneinfassprofil</p>  <p>E 363</p>	<p>Gardinenschiene</p>  <p>E 364</p>
<p>Gardinengleiter</p>  <p>E 365</p>	<p>Abdeckprofil</p>  <p>E 366</p>	<p>E 367</p>
<p>Y-Profil</p>  <p>E 368</p>	<p>Plattenverbinder</p>  <p>E 369</p>	<p>Rundschnur</p>  <p>E 370</p>
<p>Flachband</p>  <p>E 371</p>	<p>Sonderprofil</p>  <p>E 372</p>	<p>Flachband</p>  <p>E 373</p>

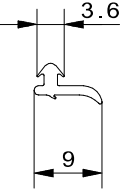
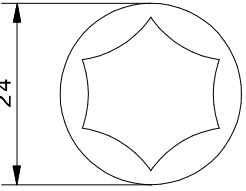

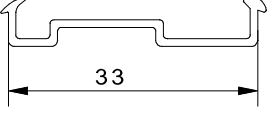
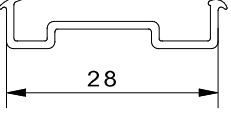
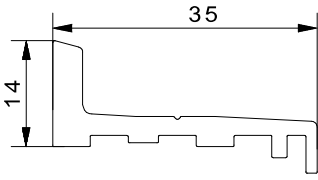
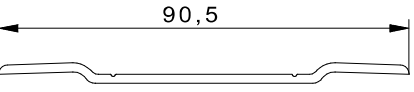
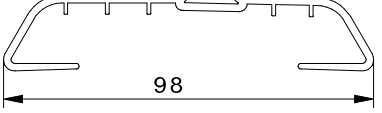
	<p>Sonderprofil</p> <p>E 374</p>	<p>Sonderprofil</p> <p>E 375</p>	<p>Sonderprofil</p> <p>E 376</p>
<p>Biese</p> <p>E 377</p>	<p>Biese</p> <p>E 378</p>	<p>Abdeckprofil</p> <p>E 379</p>	
<p>Leistenfüller</p> <p>E 380</p>	<p>Dichtungsprofil</p> <p>E 381</p>	<p>Leistenfüller</p> <p>E 382</p>	
<p>Flachband</p> <p>E 383</p>	<p>Sonderprofil</p> <p>E 384</p>	<p>Sonderprofil</p> <p>E 385</p>	
<p>Biese</p> <p>E 386</p>	<p>Leistenfüller</p> <p>E 387</p>	<p>Plattenverbinder</p> <p>E 388</p>	
<p>Sonderprofil</p> <p>E 389</p>	<p>Unterlegprofil</p> <p>E 390</p>	<p>Leistenfüller</p> <p>E 391</p>	
<p>Leistenfüller</p> <p>E 392</p>	<p>Leistenfüller</p> <p>E 393</p>	<p>Leistenfüller</p> <p>E 394</p>	

<p>Y-Profil</p>  <p>E 395</p>	<p>Leistenfüller</p>  <p>E 396</p>	<p>Kantenschutz</p>  <p>E 397</p>
<p>Unterlegprofil</p>  <p>E 398</p>	<p>Flachband</p>  <p>E 399</p>	<p>Butylband</p>  <p>E 400</p>
<p>Butylband</p>  <p>E 401</p>	<p>Butylband</p>  <p>E 402</p>	<p>Rundschnur</p>  <p>E 403</p>
<p>Frei</p> <p>E 404</p>	<p>Sockelleiste</p>  <p><i>Verkleinert</i></p> <p>E 405</p>	<p>Sockelleiste</p>  <p>E 406</p>
<p>Frei</p> <p>E 407</p>	<p>Frei</p> <p>E 408</p>	<p>Frei</p> <p>E 409</p>
<p>Frei</p> <p>E 410</p>	<p>Frei</p> <p>E 411</p>	<p>Frei</p> <p>E 412</p>
<p>Frei</p> <p>E 413</p>	<p>Übergangprofil</p>  <p>E 414</p>	<p>Sockelleiste</p>  <p><i>Verkleinert</i></p> <p>E 415</p>

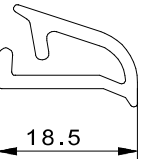
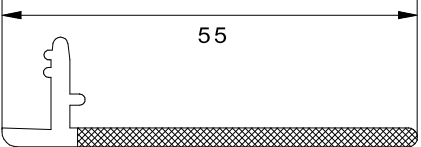
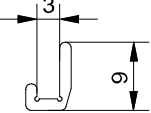
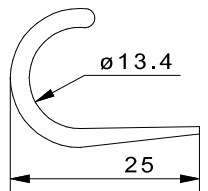
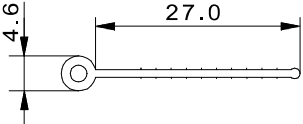
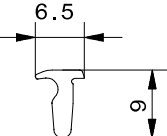
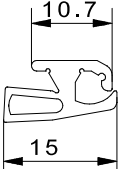

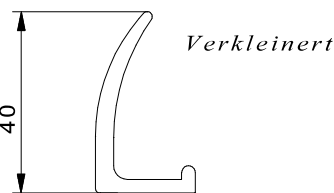
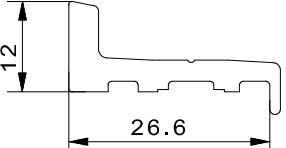

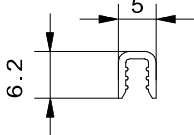
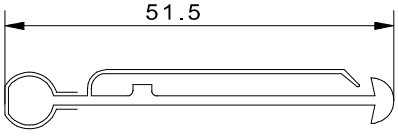
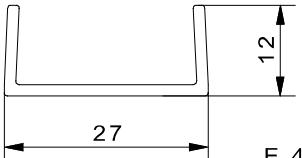
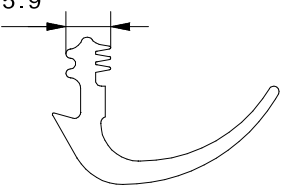
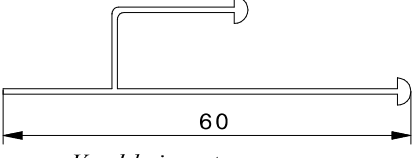
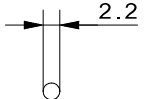
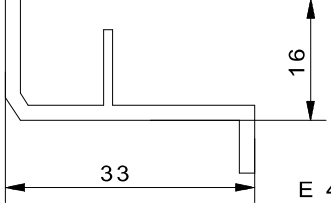
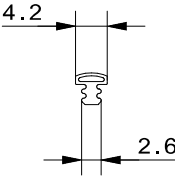
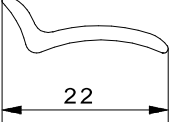
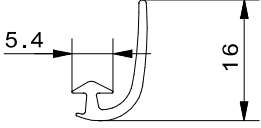
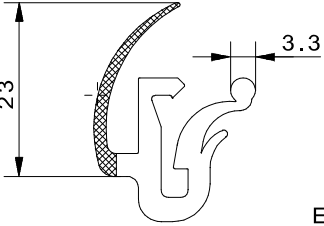
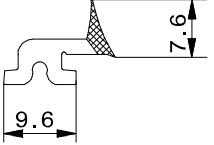
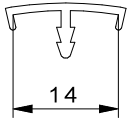
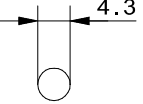
<p>Sockelleiste</p>  <p>E 416</p>	<p>Kantenschutz</p>  <p>E 417</p>	<p>Abdichtprofil</p>  <p>E 418</p>
<p>Leistenfüller</p>  <p>E 419</p>	<p>Kantenschutz</p>  <p>E 420</p>	<p>Flachband</p>  <p>E 421</p>
<p>Leistenfüller</p>  <p>E 422</p>	<p>Sonderprofil</p>  <p>E 423</p>	<p>Butylband</p>  <p>E 424</p>
<p>Sonderprofil</p>  <p>E 425</p>	<p>Winkelprofil</p>  <p>E 426</p>	<p>Leistenfüller</p>  <p>E 427</p>
<p>Sonderprofil</p>  <p>E 428</p>	<p>Winkelprofil</p>  <p>E 429</p>	<p>Verbundprofil</p>  <p>E 430</p>
<p>Schlauch</p>  <p>E 431</p>	<p>Schlauch</p>  <p>E 432</p>	<p>Schlauch</p>  <p>E 433</p>
<p>Schlauch</p>  <p>E 434</p>	<p>Schlauch</p>  <p>E 435</p>	<p>Butylband</p>  <p>E 436</p>

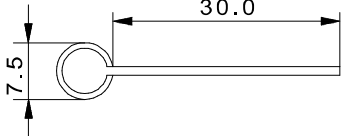
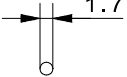
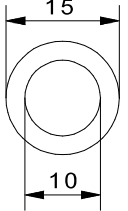
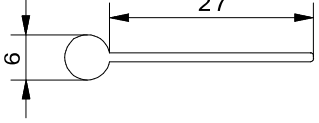
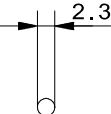
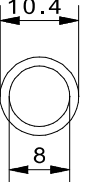

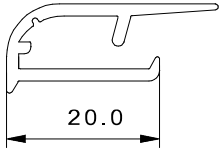
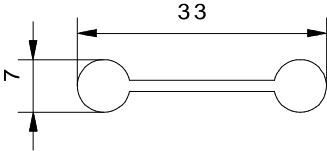
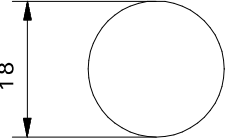
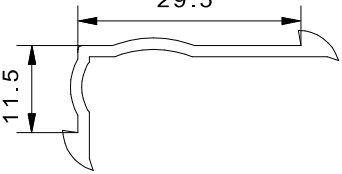

<p>Sonderprofil</p>  <p>E 437</p>	<p>Butylband</p>  <p>E 438</p>	<p>Leistenfüller</p>  <p>E 439</p>
<p>Unterlegprofil</p>  <p>E 440</p>	<p>Abdeckkleiste</p>  <p>E 441</p>	<p>Klemmprofil</p>  <p>E 442</p>
<p>Flachband</p>  <p>E 443</p>	<p>Winkelprofil</p>  <p>E 444</p>	<p>Flachband</p>  <p>E 445</p>
<p>E 446</p>	<p>Kantenschutz</p>  <p>E 447</p>	<p>Dichtungsprofil</p>  <p>E 448</p>
<p>Sonderprofil</p>  <p>E 449</p>	<p>Sonderprofil</p>  <p>E 450</p>	<p>Unterlegprofil</p>  <p>E 451</p>
<p>Leistenfüller</p>  <p>E 452</p>	<p>Nutenfüller</p>  <p>E 453</p>	<p>Klemmprofil</p>  <p>E 454</p>
<p>Schlauch</p>  <p>E 455</p>	<p>Sonderprofil</p>  <p>E 456</p>	<p>Sonderprofil</p>  <p>E 457</p>

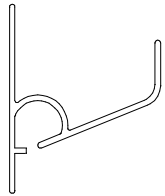
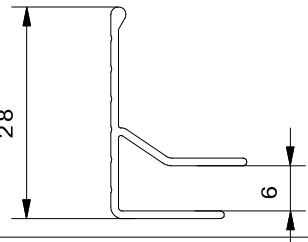
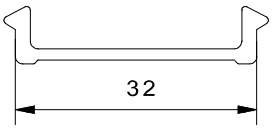
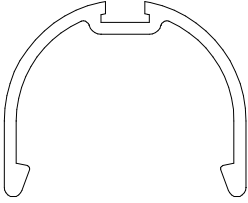
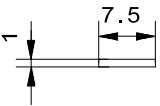
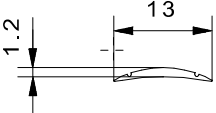
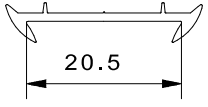

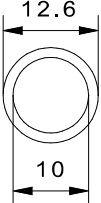
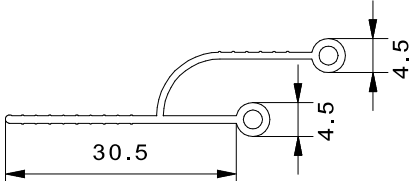
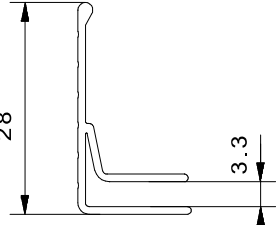
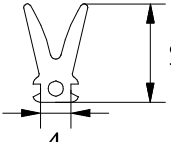
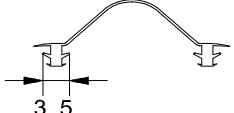
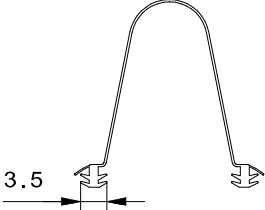
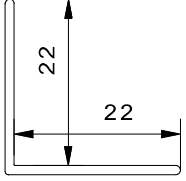
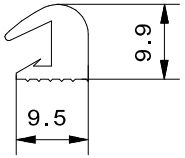

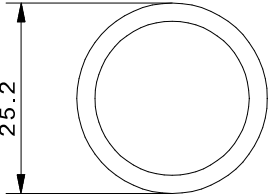
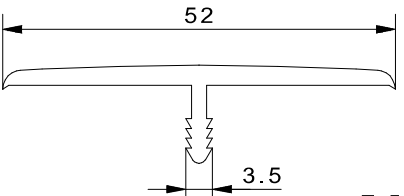
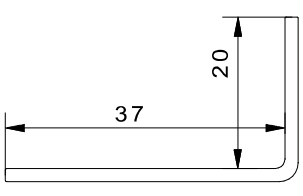
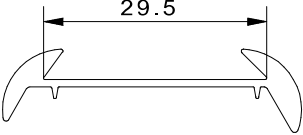

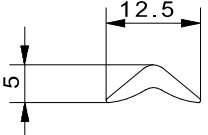
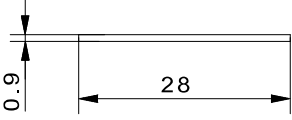
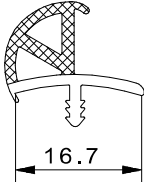
<p>Unterlegprofil</p>  <p>E 458</p>	<p>Sonderprofil</p>  <p>E 459</p>	<p>Sonderprofil</p>  <p>E 460</p>
<p>Unterlegprofil</p>  <p>E 461</p>	<p>Unterlegprofil</p>  <p>E 462</p>	<p>Sonderprofil</p>  <p>E 463</p>
<p>Rammschutzleiste</p>  <p><i>Verkleinert</i></p> <p>E 464</p>	<p>Rammschutzleiste</p>  <p><i>Verkleinert</i></p> <p>E 465</p>	<p>Sonderprofil</p>  <p>E 466</p>
<p>Butylband</p>  <p>E 467</p>	<p>Butylband</p>  <p>E 468</p>	<p>Kantenprofil</p>  <p>E 469</p>
<p>Abdeckprofil</p>  <p>E 470</p>	<p>Sonderprofil</p>  <p>E 471</p>	<p>Sonderprofil</p>  <p>E 472</p>
<p>Hohlbiege</p>  <p>E 473</p>	<p>Nutabdeckung</p>  <p>E 474</p>	<p>Sonderprofil</p>  <p>E 475</p>
<p>Rundschnur</p>  <p>E 476</p>	<p>Sonderprofil</p>  <p><i>Verkleinert</i></p> <p>E 477</p>	<p>Sonderprofil</p>  <p>E 478</p>

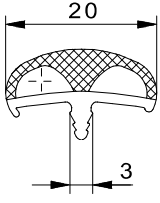
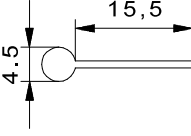
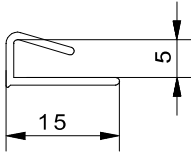
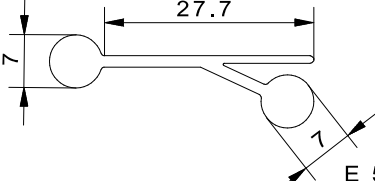
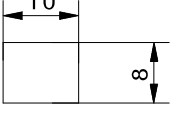
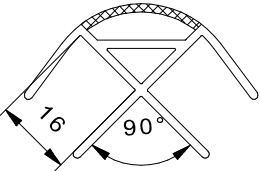
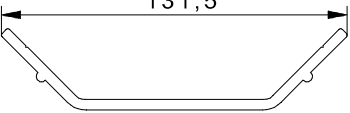
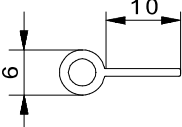
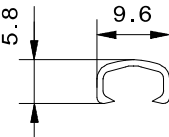
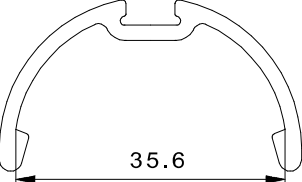
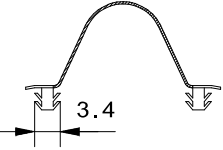

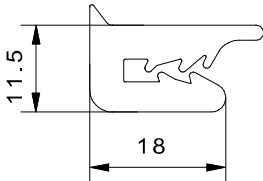
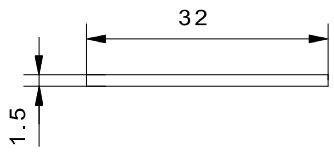
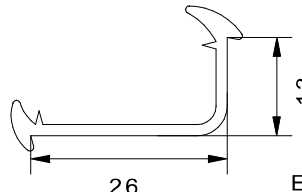
<p>Sonderprofil</p>  <p>E 479</p>	<p>Keder</p>  <p>E 480</p>	<p>U-Profil</p>  <p>E 481</p>
<p>Abdeckprofil</p>  <p>E 482</p>	<p>Keder</p>  <p>E 483</p>	<p>Rundschnur</p>  <p>E 484</p>
<p>Führungsleiste</p>  <p>E 485</p>	<p>Dichtungsprofil</p>  <p>E 486</p>	<p>Winkelprofil</p>  <p>E 487</p>
<p>Abdeckprofil</p>  <p>E 488</p>	<p>Sonderprofil</p>  <p>E 489</p>	<p>Sonderprofil</p>  <p>E 490</p>
<p>Stegumleimer</p>  <p>E 491</p>	<p>Rundschnur</p>  <p>E 492</p>	<p>Keder</p>  <p>E 493</p> <p><i>z.Zt.nicht verfügbar</i></p>
<p>Keder</p>  <p>E 494</p>	<p>Rundschnur</p>  <p>E 495</p>	<p>Schlauch</p>  <p>E 496</p>
<p>Keder</p>  <p>E 497</p>	<p>Rundschnur</p>  <p>E 498</p>	<p>Schlauch</p>  <p>E 499</p>

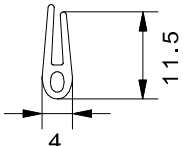
<p>Abdeckprofil</p> <p>E 500</p>	<p>Sonderprofil</p> <p>E 501</p>	<p>Sonderprofil</p> <p>E 502</p>
<p>Keder</p> <p>E 503</p>	<p>Ausfallsicherung</p> <p>E 504</p>	<p>Bodenleiste</p> <p>E 505</p>
<p>Leistenfüller</p> <p>E 506</p>	<p>Stegumleimer</p> <p>E 507</p>	<p>Abdeckprofil</p> <p>E 508</p>
<p>Unterlegprofil</p> <p>E 509</p>	<p>Leistenfüller</p> <p>E 510</p>	<p>Keder</p> <p>E 511</p>
<p>Abdichtprofil</p> <p>E 512</p>	<p>Sonderprofil</p> <p>E 513</p>	<p>Winkelprofil</p> <p>E 514</p>
<p>Schlauch</p> <p>E 515</p>	<p>Abdeckprofil</p> <p>E 516</p>	<p>Winkelprofil</p> <p>E 517</p>
<p>Schlauch</p> <p>E 518</p>	<p>Sonderprofil</p> <p>E 519</p>	<p>Sonderprofil</p> <p>E 520</p>

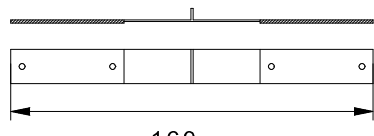
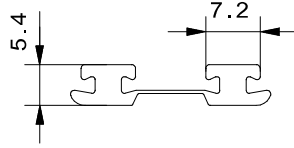
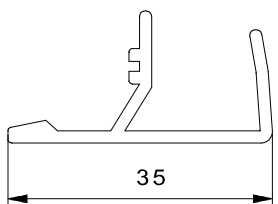
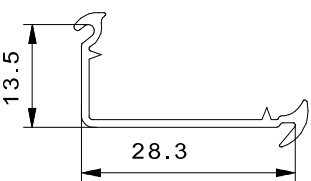

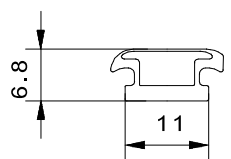
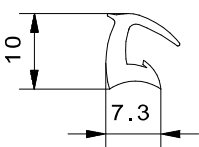
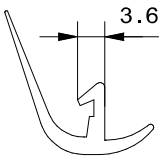
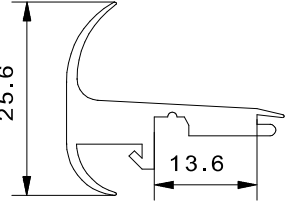
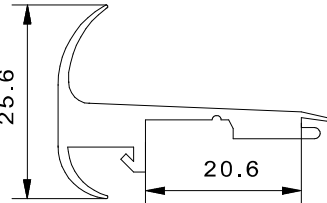
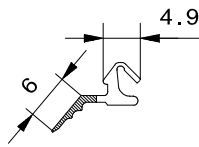
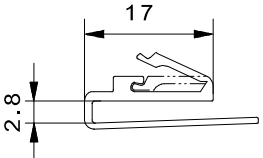
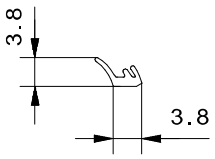
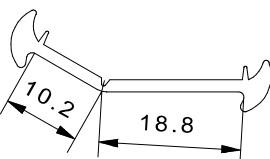
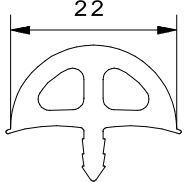

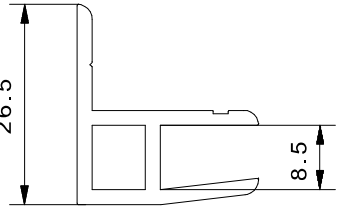
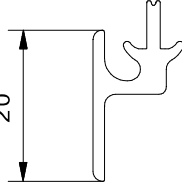
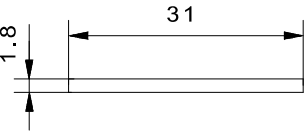
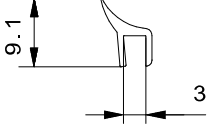
<p>Kantenprofil</p>  <p>E 521</p>	<p>Keder</p>  <p>E 522</p>	<p>Rundschnur</p>  <p>E 523</p>
<p>Winkelprofil</p>  <p>E 524</p>	<p>Butylband</p>  <p>E 525</p>	<p>Sonderprofil</p>  <p>E 526</p>
<p>Ausfallsicherung</p>  <p>E 527</p>	<p>Kabelkanal</p>  <p>E 528</p>	<p>Kabelkanal</p>  <p>E 529</p>
<p>Flachband</p>  <p>E 530</p>	<p>Leistenfüller</p>  <p>E 531</p>	<p>Unterlegprofil</p>  <p>E 532</p>
<p>Butylband</p>  <p>E 533</p>	<p>Schlauch</p>  <p>E 534</p>	<p>Keder</p>  <p>E 535</p>
<p>Ausfallsicherung</p>  <p>E 536</p>	<p>Dichtprofil</p>  <p>E 537</p>	<p>Gelenkdichtung</p>  <p>E 538</p>
<p>Gelenkdichtung</p>  <p>E 539</p>	<p>Winkelprofil</p>  <p>E 540</p>	<p>Sonderprofil</p>  <p>E 541</p>

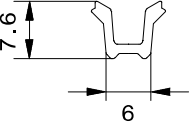
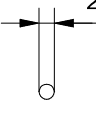
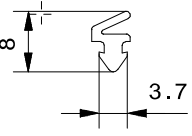
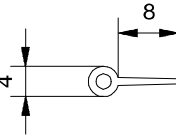
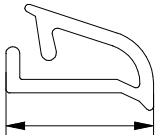
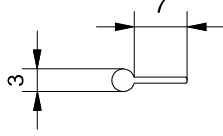
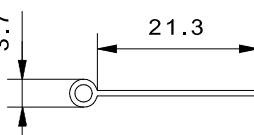
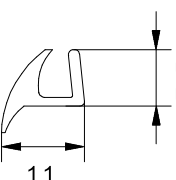
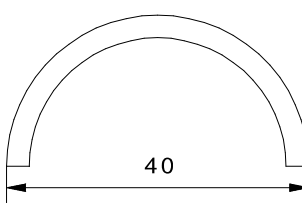
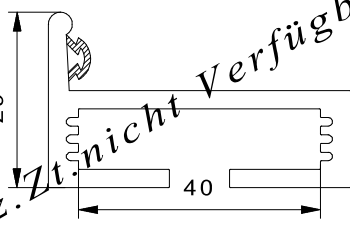
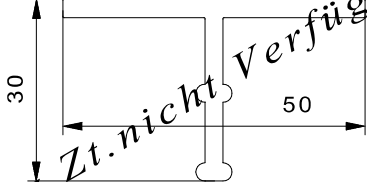
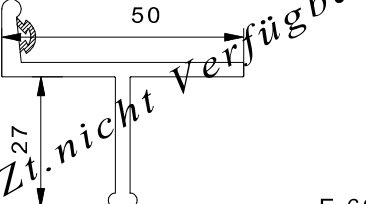
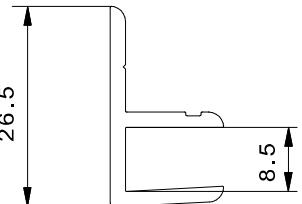
<p>Schlauch</p>  <p>E 542</p>	<p>Stegumleimer</p>  <p>E 543</p>	<p>Winkelprofil</p>  <p>E 544</p>
<p>Unterlegprofil</p>  <p>E 545</p>	<p>Butylband</p>  <p>E 546</p>	<p>Leistenfüller</p>  <p>E 547</p>
<p>Flachband</p>  <p>E 548</p>	<p>Stegumleimer</p>  <p>E 549</p>	<p>Butylband</p>  <p>E 550</p>
<p>Butylband</p>  <p>E 551</p>	<p>Stegumleimer</p>  <p>E 552</p>	<p>Keder</p>  <p>E 553</p>
<p>Abschlußprofil</p>  <p>E 554</p>	<p>Keder</p>  <p>E 555</p>	<p>Vierkantprofil</p>  <p>E 556</p>
<p>Eckverbinder 90°</p>  <p>E 557</p>	<p>Kantenprofil</p>  <p><i>Verkleinert</i></p> <p>E 558</p>	<p>Hohlbiese</p>  <p>E 559</p>
<p>Abdeckprofil</p>  <p>E 560</p>	<p>Kabelkanal</p>  <p>E 561</p>	<p>Gelenkdichtung</p>  <p>E 562</p>

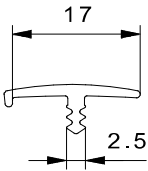
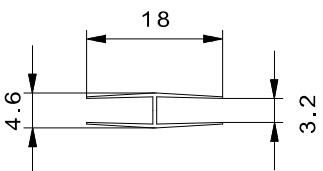
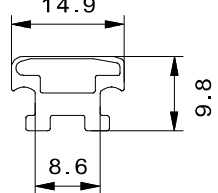
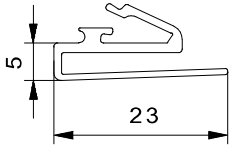
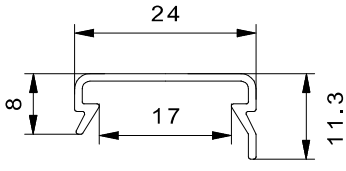
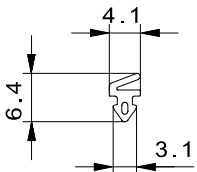
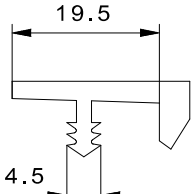
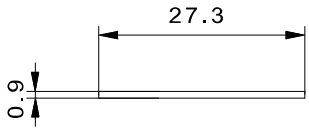
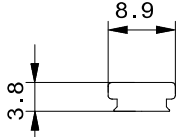
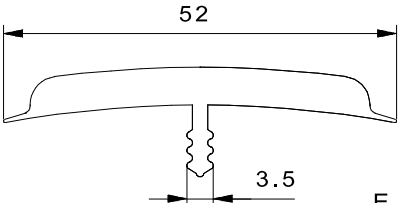
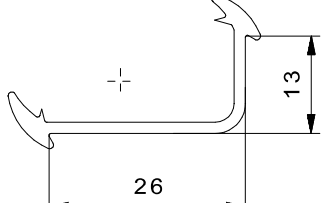
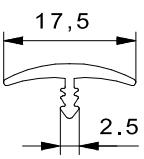
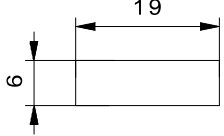
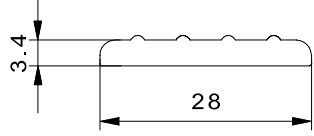
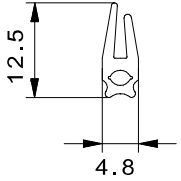
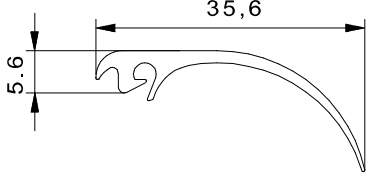
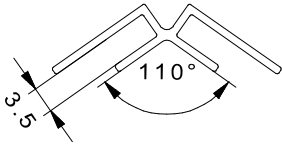
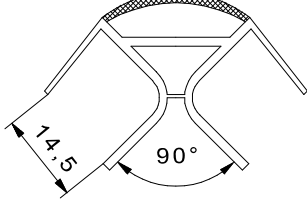
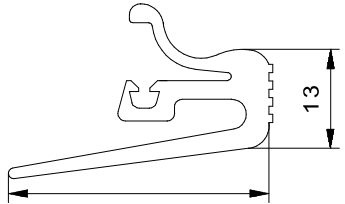
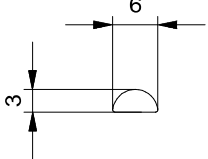
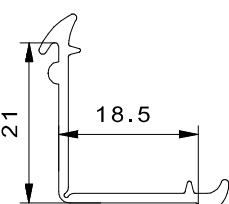

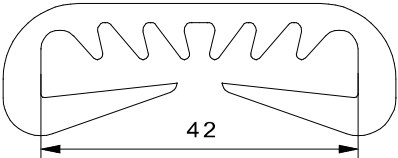

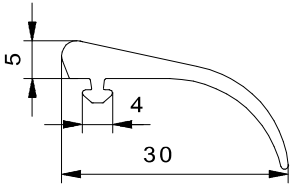
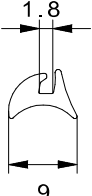
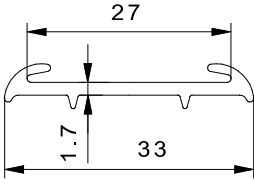
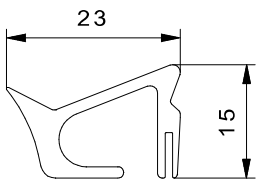
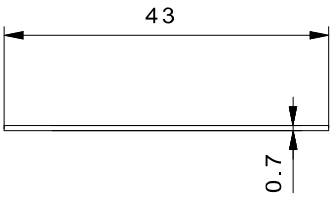
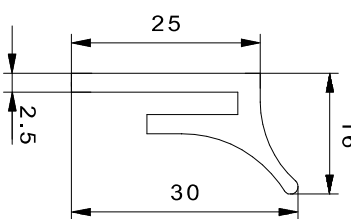
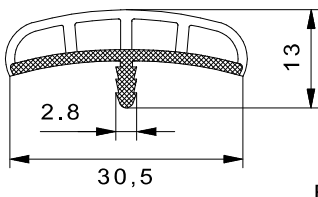
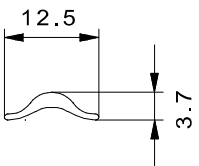
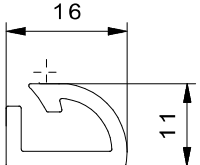
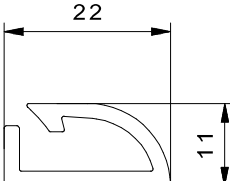
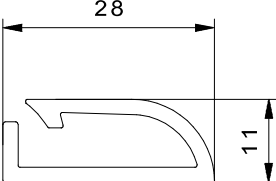
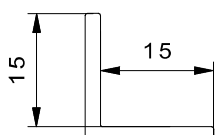
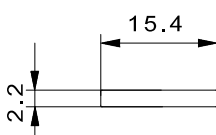
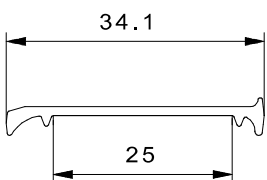

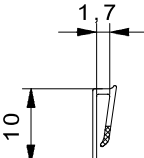
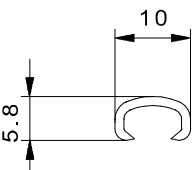
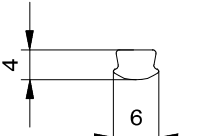
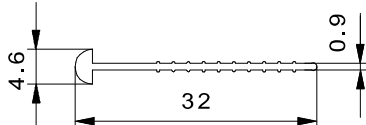
<p>Kantenschutz</p>  <p>E 563</p>	<p>Butylband</p>  <p>E 564</p>	<p>Winkelprofil</p>  <p>E 565</p>
<p>Butylband</p>  <p>E 566</p>	<p>Dichtungsprofil</p>  <p>E 567</p>	<p>Dichtungsprofil</p>  <p>E 568</p>
<p>Sonderprofil</p> <p><i>Verkleinert</i></p>  <p>E 569</p>	<p>Sonderprofil</p>  <p>E 570</p>	<p>Ausfallsicherung</p>  <p>E 571</p>
<p>Winkelprofil</p>  <p>E 572</p>	<p>Butylband</p>  <p>E 573</p>	<p>Sonderprofil</p>  <p>E 574</p>
<p>Türrahmenprofil</p>  <p>E 575</p>	<p>Türabdeckung</p>  <p>E 576</p>	<p>Sonderprofil</p>  <p>E 577</p>
<p>Sonderprofil</p>  <p>E 578</p>	<p>Dichtungsprofil</p>  <p>E 579</p>	<p>Sonderprofil</p>  <p>E 580</p>
<p>Dichtungsprofil</p>  <p>E 581</p>	<p>Winkelprofil</p>  <p>E 582</p>	<p>Stegumleimer</p>  <p>E 583</p>

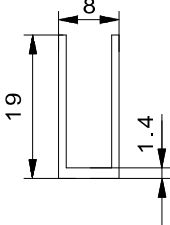
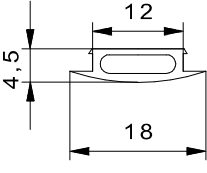
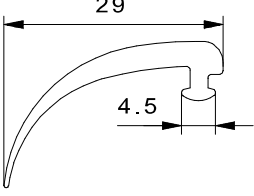
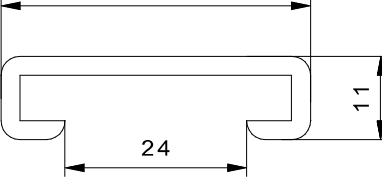
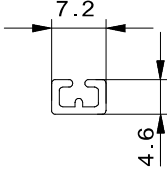
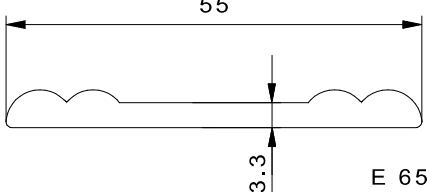
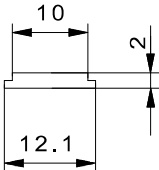
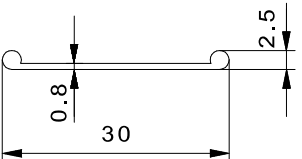
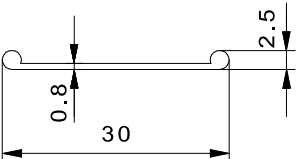
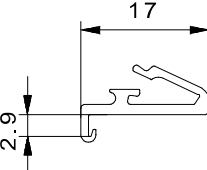
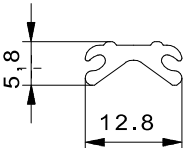
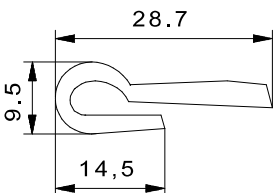
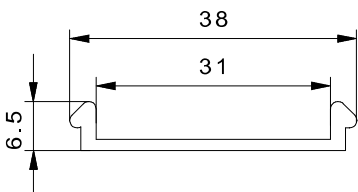
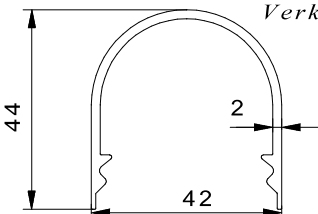
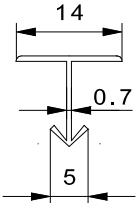
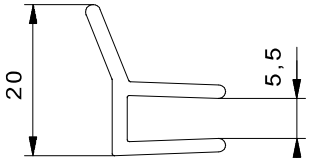
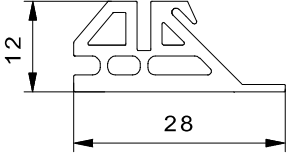
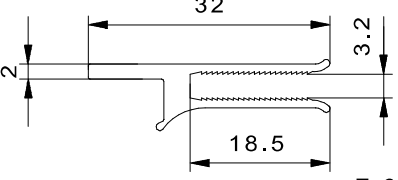
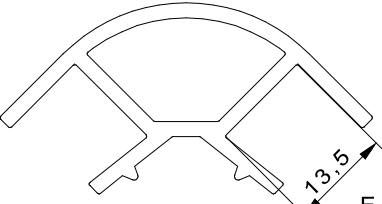
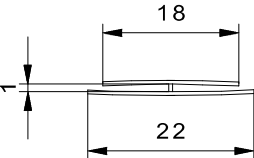
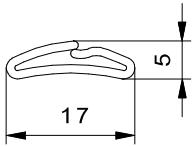
<p>Abstandshalter</p>  <p>E 584</p>	<p>Sonderprofil</p>  <p>E 585</p>	<p>Flachband</p>  <p>E 586</p>
<p>Abdeckprofil</p>  <p>E 587</p>	<p>Butylband</p>  <p>E 588</p>	<p>Klemmprofil</p>  <p>E 589</p>
<p>Rundschnur</p>  <p>E 590</p>	<p>Dichtungsprofil</p>  <p>E 593</p>	<p>Hohlbiese</p>  <p>E 591</p>
<p>Radkastenabdeckung</p>  <p>E 596</p>	<p>Biese</p>  <p>E 597</p>	<p>Hohlbiese</p>  <p>E 594</p>
<p>Unterlegprofil</p>  <p>E 599</p>	<p>Halbschale</p>  <p>E 600</p>	<p>Sonderprofil</p>  <p>E 601</p>
<p>Sonderprofil</p>  <p>E 602</p>	<p>Sonderprofil</p>  <p>E 603</p>	<p>Ausfallsicherung</p>  <p>E 604</p>

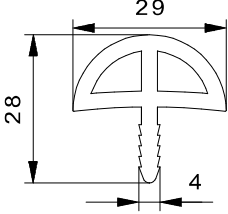
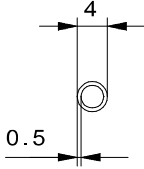
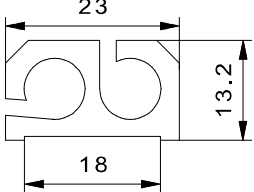
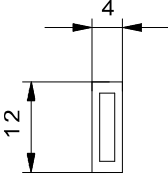
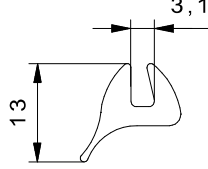
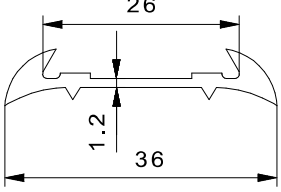
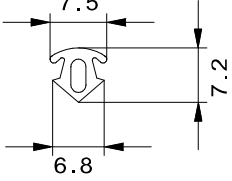
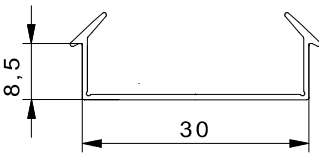
<p>Stegumleimer</p>  <p>E 605</p>	<p>Plattenverbinder</p>  <p>E 606</p>	<p>Sonderprofil</p>  <p>E 607</p>
<p>Sonderprofil</p>  <p>E 608</p>	<p>Abdeckprofil</p>  <p>E 609</p>	<p>Dichtprofil</p>  <p>E 610</p>
<p>Stegumleimer</p>  <p>E 611</p>	<p>Flachband</p>  <p>E 612</p>	<p>Leistenfüller</p>  <p>E 613</p>
<p>Stegumleimer</p>  <p>E 614</p>	<p>Winkelprofil</p>  <p>E 615</p>	<p>Stegumleimer</p>  <p>E 616</p>
<p>Flachband</p>  <p>E 617</p>	<p>Bodenleiste</p>  <p>E 618</p>	<p>Dichtprofil</p>  <p>E 619</p>
<p>Abdeckprofil</p>  <p>E 620</p>	<p>Plattenverbinder 110°</p>  <p>E 621</p>	<p>Eckverbinder 90°</p>  <p>E 622</p>
<p>Sonderprofil</p>  <p>E 623</p>	<p>Halbrundprofil</p>  <p>E 624</p>	<p>Winkelprofil</p>  <p>E 625</p>

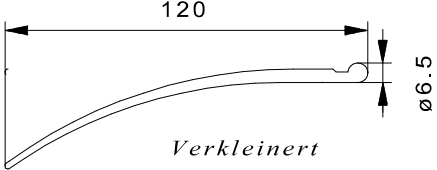
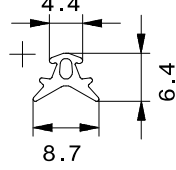
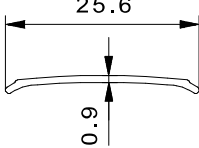
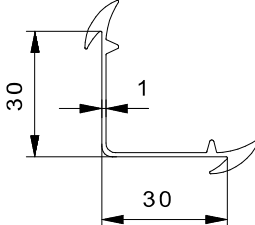
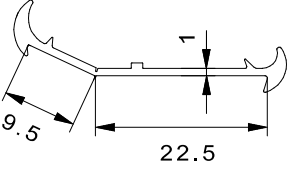
<p>Handlauf</p>  <p>E 626</p>	<p>Butylband</p>  <p>E 627</p>	<p>Abdeckprofil</p>  <p>E 628</p>
<p>Unterlegprofil</p>  <p>E 629</p>	<p>Unterlegprofil</p>  <p>E 630</p>	<p>Sonderprofil</p>  <p>E 631</p>
<p>Flachband</p>  <p>E 632</p>	<p>Abdeckprofil</p>  <p>E 633</p>	<p>Stegumleimer</p>  <p>E 634</p>
<p>Leistenfüller</p>  <p>E 635</p>	<p>Radkastenabdeckung</p>  <p>E 636</p>	<p>Radkastenabdeckung</p>  <p>E 637</p>
<p>Radkastenabdeckung</p>  <p>E 638</p>	<p>Winkelprofil</p>  <p>E 639</p>	<p>Flachband</p>  <p>E 640</p>
<p>Unterlegprofil</p>  <p>E 641</p>	<p>Butylband</p>  <p>E 642</p>	<p>Kantenschutz</p>  <p>E 643</p>
<p>Zierleiste</p>  <p>E 644</p>	<p>Leistenfüller</p>  <p>E 645</p>	<p>Keder</p>  <p>E 646</p>

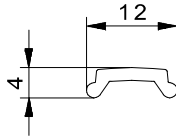
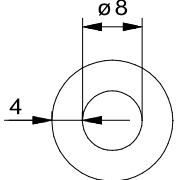
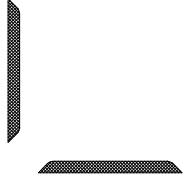
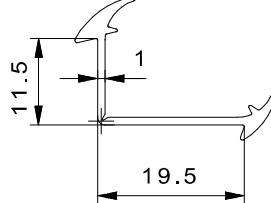

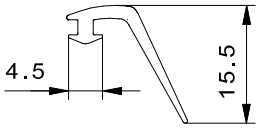
<p>Kantenschutz</p>  <p>E 647</p>	<p>Leistenfüller</p>  <p>E 648</p>	<p>Abdeckprofil</p>  <p>E 649</p>
<p>Handlauf</p>  <p>E 650</p>	<p>Sonderprofil</p>  <p>E 651</p>	<p>Gurtband</p>  <p>E 652</p>
<p>Leistenfüller</p>  <p>E 653</p>	<p>Butylband</p>  <p>E 654</p>	<p>Doppelwulstkeder</p>  <p>E 655</p>
<p>Sonderprofil</p>  <p>E 656</p>	<p>Leistenfüller</p>  <p>E 657</p>	<p>Kantenschutz</p>  <p>E 658</p>
<p>Kabelkanal</p>  <p>E 659</p>	<p>Kabelkanal <i>Verkleinert</i></p>  <p>E 660</p>	<p>Eindrückprofil</p>  <p>E 661</p>
<p>Staukastenprofil</p>  <p>E 662</p>	<p>Sonderprofil</p>  <p>E 663</p>	<p>Sonderprofil</p>  <p>E 664</p>
<p>Eckverbinder 90°</p>  <p>E 665</p>	<p>Plattenverbinder</p>  <p>E 666</p>	<p>Sonderprofil</p>  <p>E 667</p>

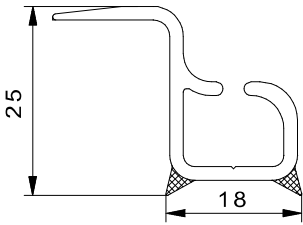
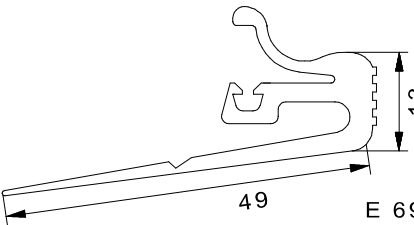
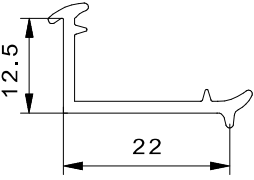
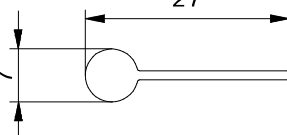
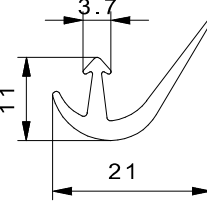
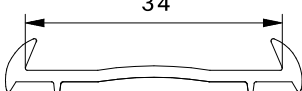
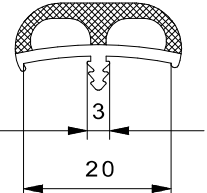
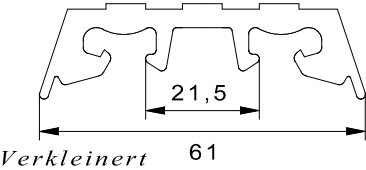
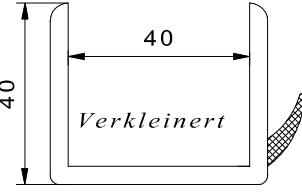
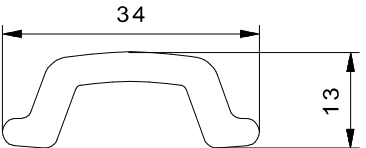
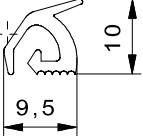
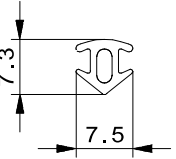
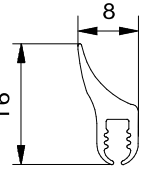
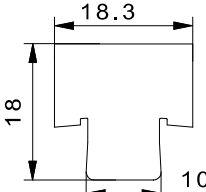
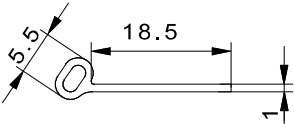
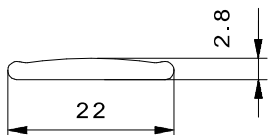
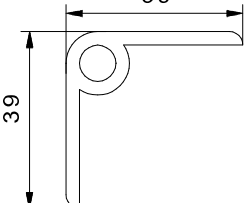
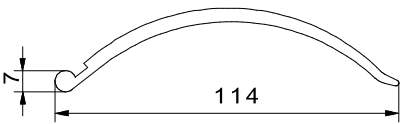
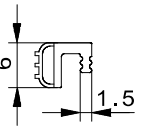
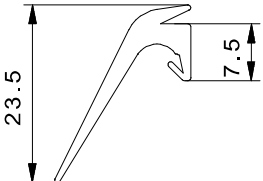
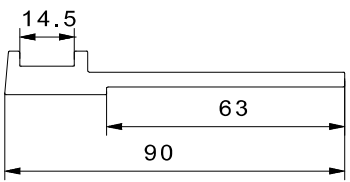

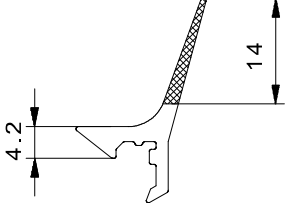
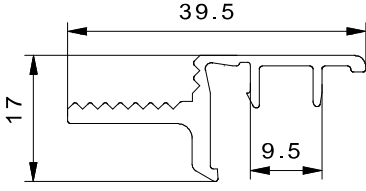
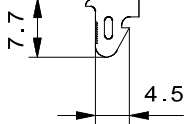
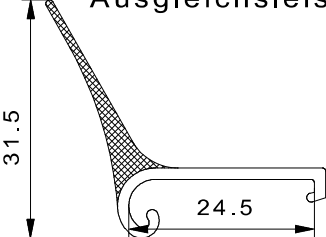
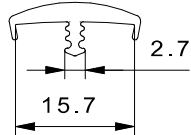
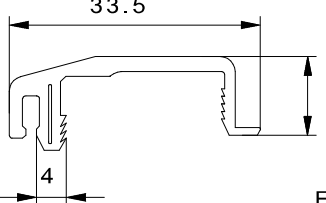
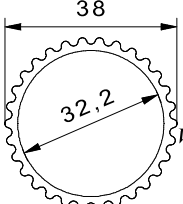
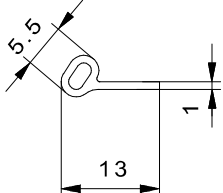
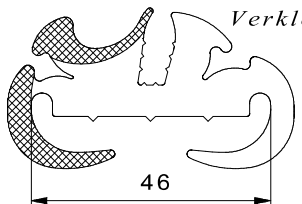
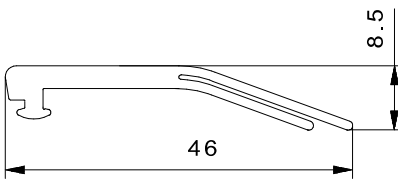
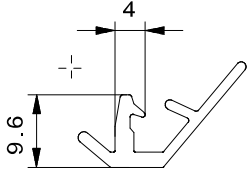
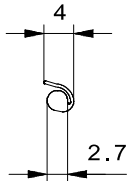
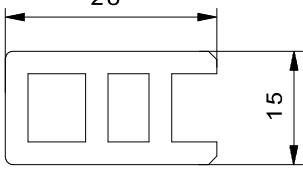
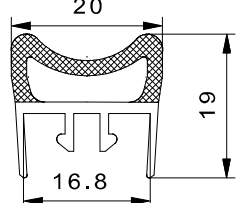
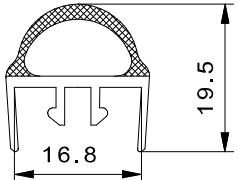
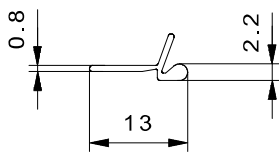
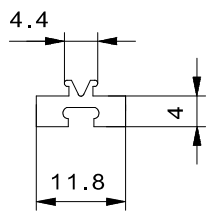
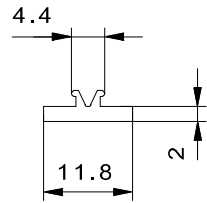
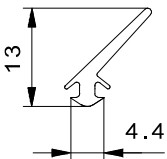
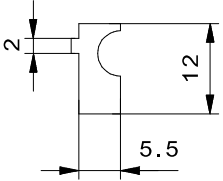
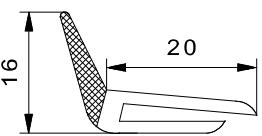
<p>Stegumleimer</p>  <p>E 668</p>	<p>Schlauch</p>  <p>E 669</p>	<p>Einzugleiste</p>  <p>E 670</p>
<p>Vierkantrohr</p>  <p>E 671</p>	<p>Unterlegprofil</p>  <p>E 672</p>	<p>Unterlegprofil</p>  <p>E 673</p>
<p>Nutabdeckung</p>  <p>E 674</p>	<p>Unterlegprofil</p>  <p>E 675</p>	<p>Butylband</p>  <p>E 676</p>
<p>Abdichtprofil</p>  <p>E 677</p>	<p>Dichtprofil</p>  <p>E 678</p>	<p>Leistenfüller</p>  <p>E 679</p>
<p>Winkelprofil</p>  <p>E 680</p>	<p>Winkelprofil</p>  <p>E 681</p>	<p>Butylband</p>  <p>E 682</p>
<p>Leistenfüller</p>  <p>E 683</p>	<p>Schlauch</p>  <p>E 684</p>	<p>Butylband</p>  <p>E 685</p>
<p>Winkelprofil</p>  <p>E 686</p>	<p>Butylband</p>  <p>E 687</p>	<p>Abdeckprofil</p>  <p>E 688</p>

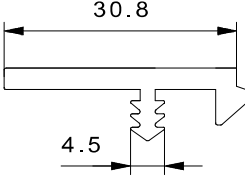
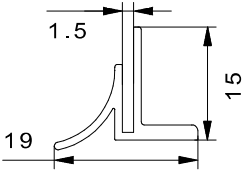
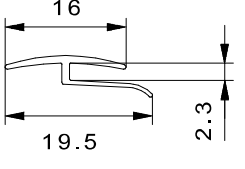
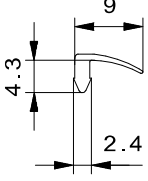
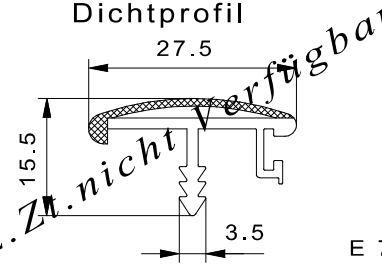
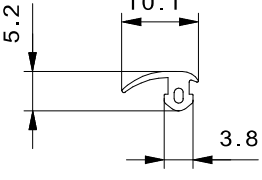
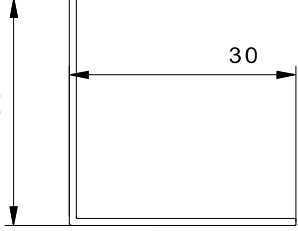
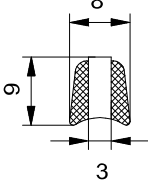
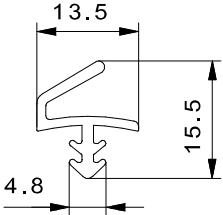
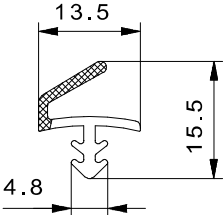
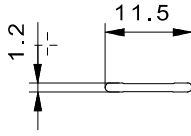
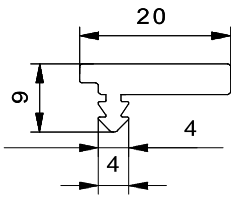
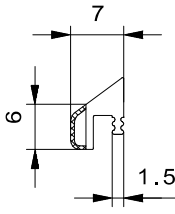
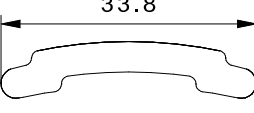
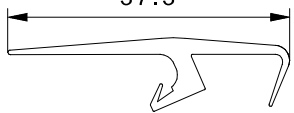
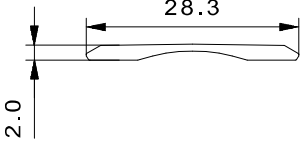
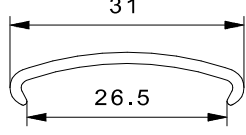
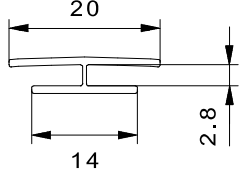
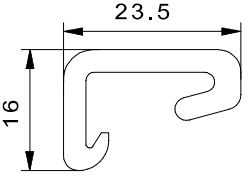
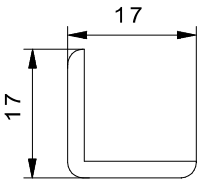
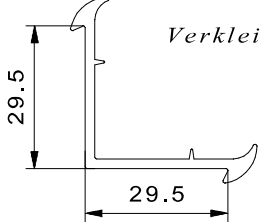
<p>Regenrinne</p>  <p>E 689</p>	<p>Sonderprofil</p>  <p>E 690</p>	<p>Winkelprofil</p>  <p>E 691</p>
<p>Keder</p>  <p>E 692</p>	<p>Abdeckprofil</p>  <p>E 693</p>	<p>Unterlegprofil</p>  <p>E 694</p>
<p>Stegumleimer</p>  <p>E 695</p>	<p>Rammschutzleiste <i>Verkleinert</i></p>  <p><i>Verkleinert</i> E 696</p>	<p>U-Profil</p>  <p><i>Verkleinert</i> E 697</p>
<p>Leistenfüller</p>  <p>E 698</p>	<p>Sonderprofil</p>  <p>E 699</p>	<p>Nutabdeckprofil</p>  <p>E 700</p>
<p>Kantenschutz</p>  <p>E 701</p>	<p>Auflageprofil</p>  <p>E 702</p>	<p>Hohlbiege</p>  <p>E 703</p>
<p>Flachband</p>  <p>E 704</p>	<p>Rahmenprofil</p>  <p>E 705</p>	<p>Abdichtprofil</p>  <p><i>Verkleinert</i> E 706</p>
<p>Türdichtung</p>  <p>E 707</p>	<p>Rahmendichtprofil</p>  <p>E 708</p>	<p>Sonderprofil</p>  <p><i>Verkleinert</i> E 709</p>

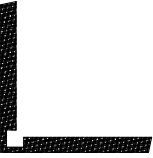
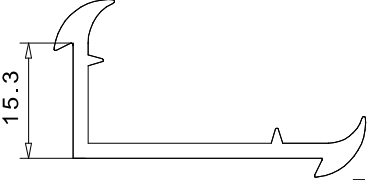
<p>Wandanschluß</p>  <p>E 710</p>	<p>Wandanschluß</p>  <p>E 711</p>	<p>Fliegengazeprofil</p>  <p>E 712</p>
<p>Ausgleichsleiste</p>  <p>E 713</p>	<p>Stegumleimer</p>  <p>E 714</p>	<p>Abdeckprofil</p>  <p>E 715</p>
<p>Riffelrohr</p>  <p>E 716</p>	<p>Hohlbiege</p>  <p>E 717</p>	<p>Fensterrahmenprofil</p>  <p>E 718</p>
<p>Rahmenabdeckung</p>  <p>E 719</p>	<p>Abdichtprofil</p>  <p>E 720</p>	<p>Dämpfprofil</p>  <p>E 721</p>
<p>Distanzprofil</p>  <p>E 722</p>	<p>Dichtungsprofil</p>  <p>E 723</p>	<p>Dichtungsprofil</p>  <p>E 724</p>
<p>Dämpfprofil</p>  <p>E 725</p>	<p>Distanzprofil</p>  <p>E 726</p>	<p>Distanzprofil</p>  <p>E 727</p>
<p>Abdichtprofil</p>  <p>E 728</p>	<p>Klemmprofil</p>  <p>E 729</p>	<p>Wandanschluß</p>  <p>E 730</p>

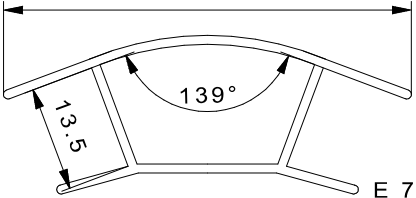
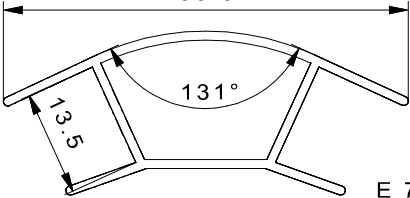
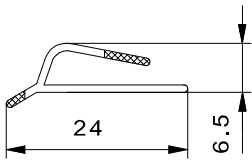
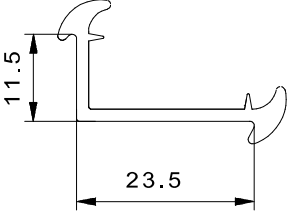
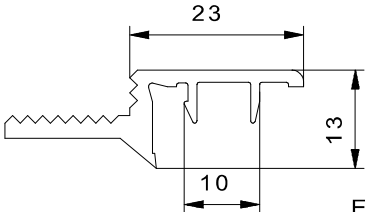
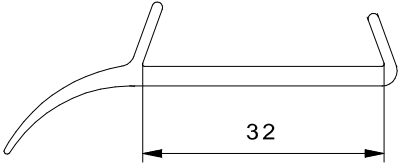
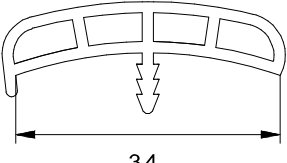
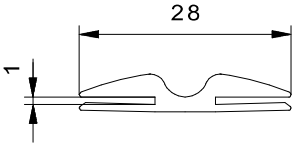
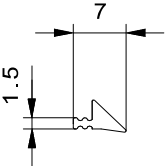
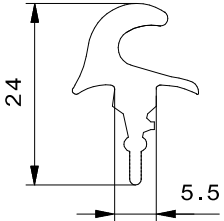
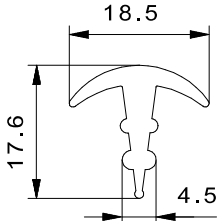
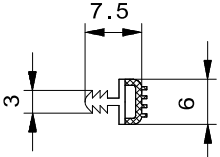
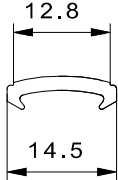
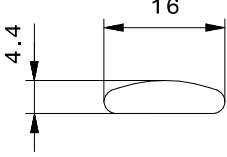
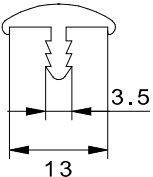
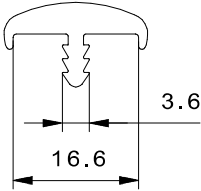
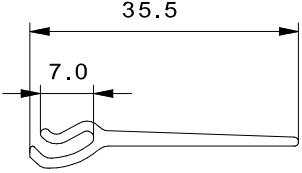

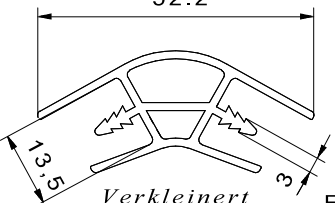
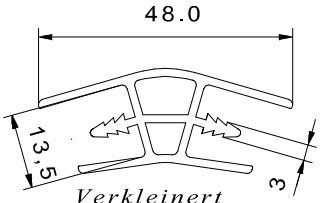
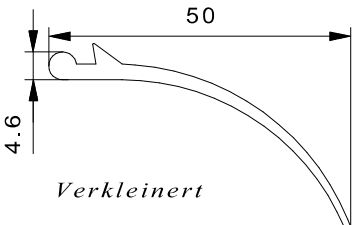
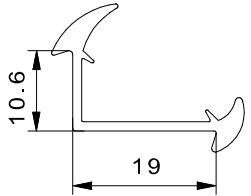
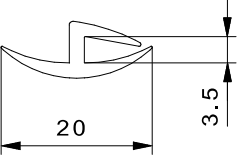
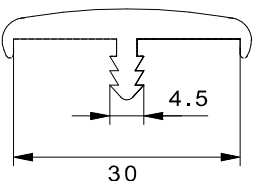
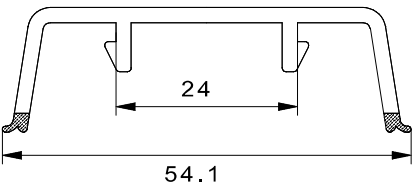
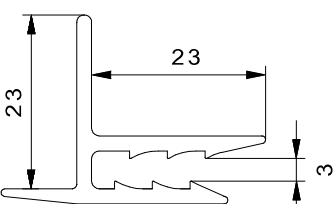
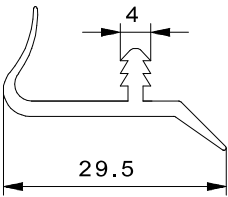
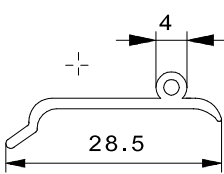
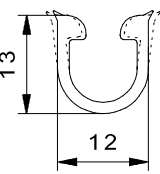
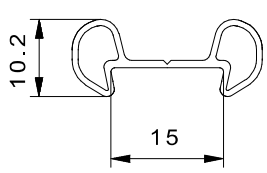
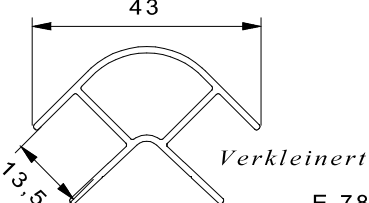
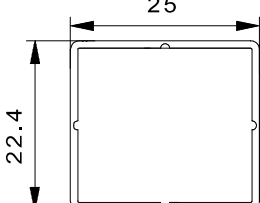
<p>Stegumleimer</p>  <p>E 731</p>	<p>Anschlußprofil</p>  <p>E 732</p>	<p>Verbindungsprofil</p>  <p>E 733</p>
<p>Dekorprofil</p>  <p>E 734</p>	<p>Dichtprofil</p>  <p>E 735</p>	<p>Abdeckprofil</p>  <p>E 736</p>
<p>Winkelprofil</p>  <p>E 737</p>	<p>Beckenabdichtung</p>  <p>E 738</p>	<p>Zargendichtung</p>  <p>E 739</p>
<p>Zargendichtung</p>  <p>E 740</p>	<p>Leistenfüller</p>  <p>E 741</p>	<p>Anschlagleiste</p>  <p>E 742</p>
<p>Anschlagdichtung</p>  <p>E 743</p>	<p>Leistenfüller</p>  <p>E 744</p>	<p>Rahmendichtung</p>  <p>E 745</p>
<p>Leistenfüller</p>  <p>E 746</p>	<p>Abdeckprofil</p>  <p>E 747</p>	<p>Plattenverbinder</p>  <p>E 748</p>
<p>Kantenschutz</p>  <p>E 749</p>	<p>Winkelprofil</p>  <p>E 750</p>	<p>Winkelprofil</p>  <p>E 751</p>

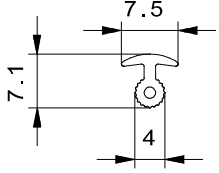
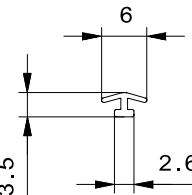
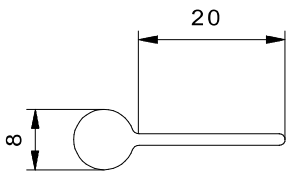
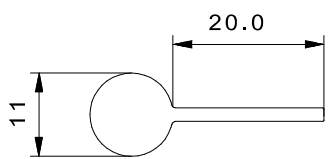
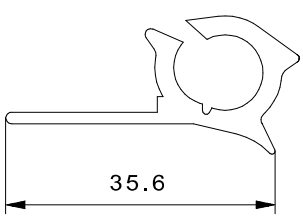

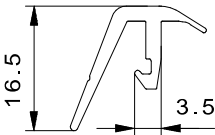
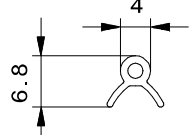
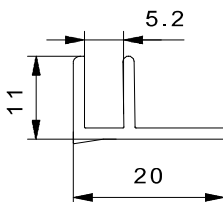
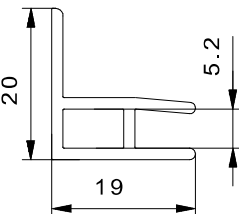
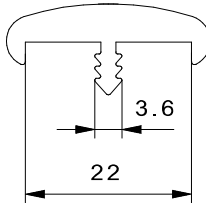
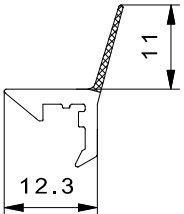
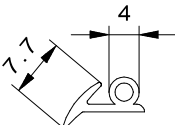
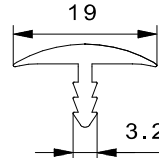
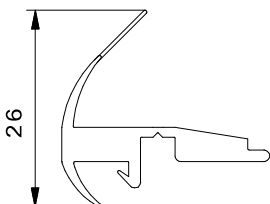
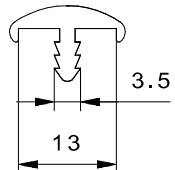
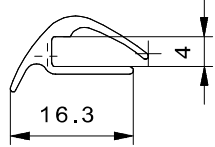
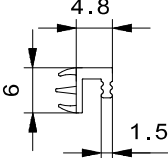
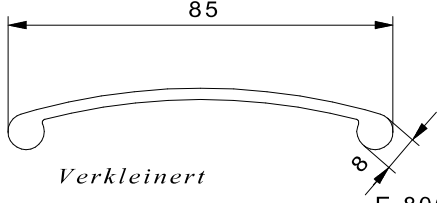
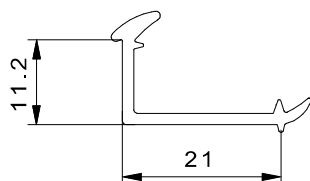
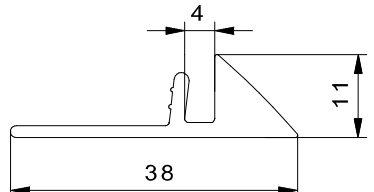
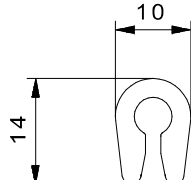
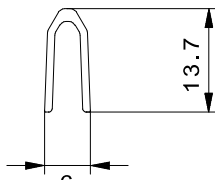
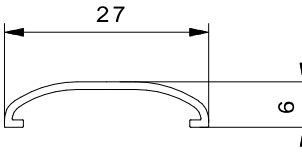
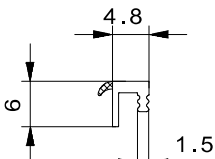
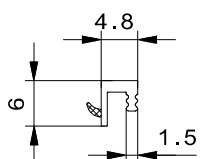
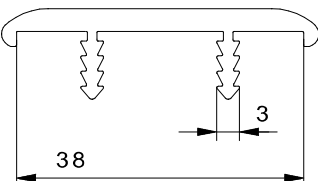
<p>Butylband</p>  <p>E 752</p>	<p>Winkelprofil</p>  <p>E 753</p>	<p>Butylband</p>  <p>E 754</p>
<p>Eckverbinder 139°</p>  <p>E 755</p>	<p>Eckverbinder 131°</p>  <p>E 756</p>	<p>Abschlußprofil</p>  <p>E 757</p>
<p>Winkelprofil</p>  <p>E 758</p>	<p>Wandanschluß</p>  <p>E 759</p>	<p>Wandanschluß</p>  <p>E 760</p>
<p>Stegumleimer</p>  <p>E 761</p>	<p>Aufstellband</p> <p>E 762</p>	<p>Plattenverbinder</p>  <p>E 763</p>
<p>Abdichtprofil</p>  <p>E 764</p>	<p>Regenrinne</p>  <p>E 765</p>	<p>Fugenabdeckung</p>  <p>E 766</p>
<p>Dichtprofil</p>  <p>E 767</p>	<p>Leistenfüller</p>  <p>E 768</p>	<p>Einschubleiste</p>  <p>E 769</p>
<p>Stegumleimer</p>  <p>E 770</p>	<p>Stegumleimer</p>  <p>E 771</p>	<p>Aufsteckprofil</p>  <p>E 772</p>

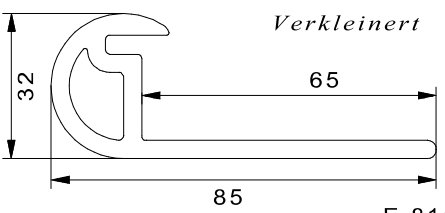
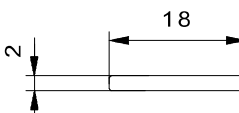
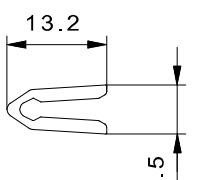
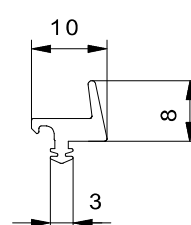
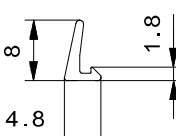
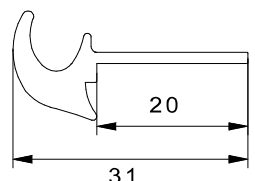
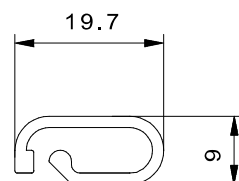
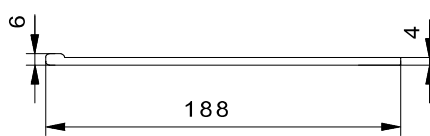
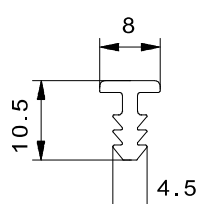
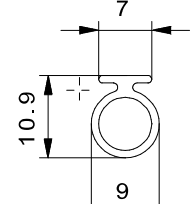
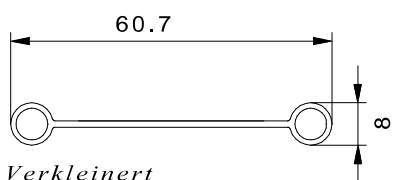
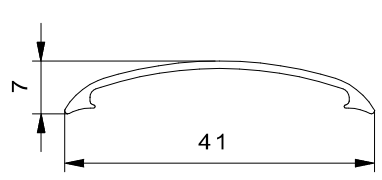
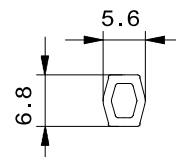
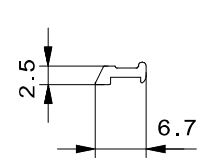
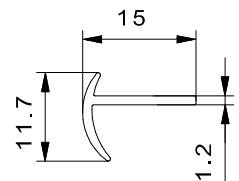
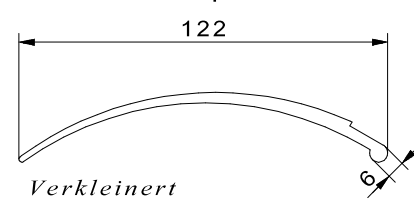
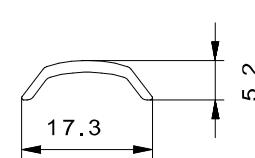
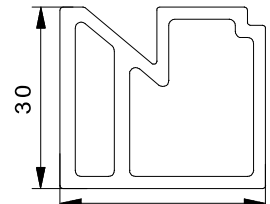
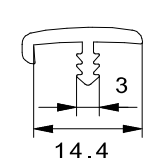

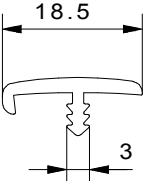
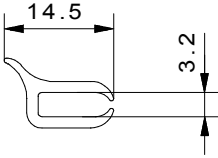
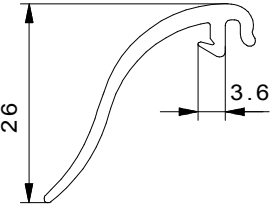
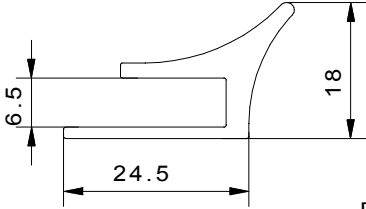
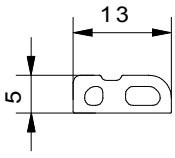
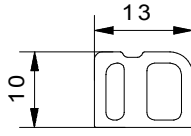
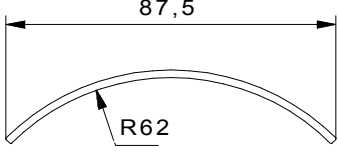
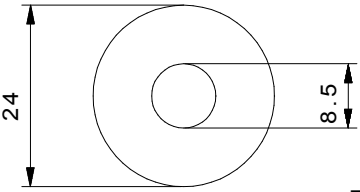
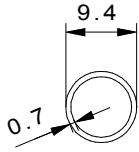
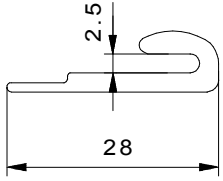
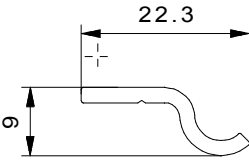
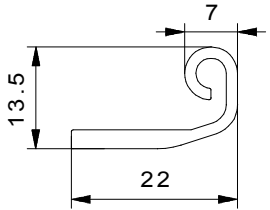
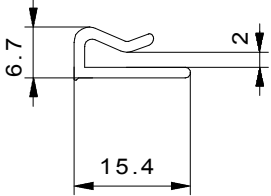
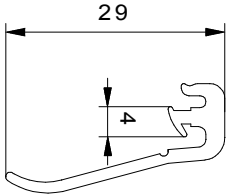
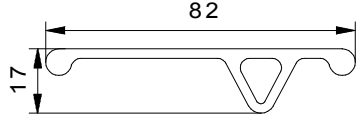
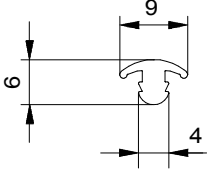
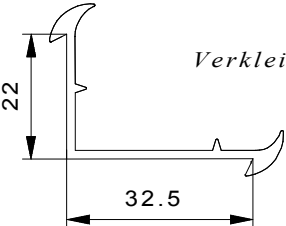
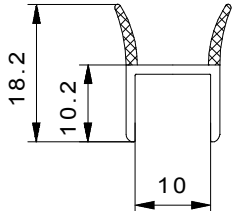
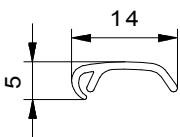
<p>Butylband</p>  <p>E 773</p>	<p>Eckverbinder 122°</p> <p>52.2</p>  <p><i>Verkleinert</i></p> <p>E 774</p>	<p>Eckverbinder 148°</p> <p>48.0</p>  <p><i>Verkleinert</i></p> <p>E 775</p>
<p>Dichtprofil</p> <p>50</p>  <p><i>Verkleinert</i></p> <p>E 776</p>	<p>Winkelprofil</p>  <p>E 777</p>	<p>Fugenabdeckung</p>  <p>E 778</p>
<p>Stegumleimer</p>  <p>E 779</p>	<p>Rammschutz</p>  <p>E 780</p>	<p>Plattenaufnahme</p>  <p>E 781</p>
<p>Einfäßleiste</p>  <p>E 782</p>	<p>Unterlegprofil</p>  <p>E 783</p>	<p>Gleitbuchse</p>  <p>E 784</p>
<p>Hohlbiege</p>  <p>E 785</p>	<p>Eckverbinder 90°</p> <p>43</p>  <p><i>Verkleinert</i></p> <p>E 786</p>	<p>Leerrohr</p> <p>25</p>  <p>E 787</p>
<p>Butylband</p>  <p>E 788</p>	<p>Klemmprofil</p>  <p>E 789</p>	<p>Dämpfungsprofil</p>  <p>E 790</p>
<p>Keder</p> <p>20</p>  <p>E 791</p>	<p>Keder</p> <p>20.0</p>  <p>E 792</p>	<p>Sonderprofil</p> <p>35.6</p>  <p>E 793</p>

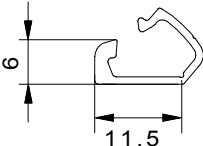

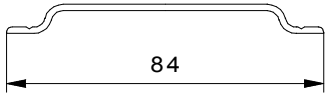
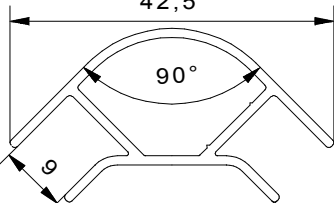
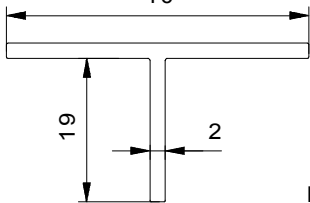
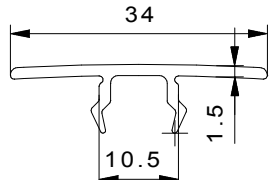
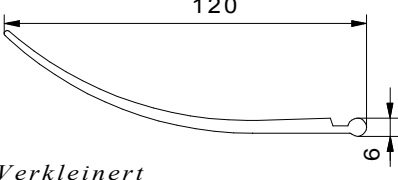
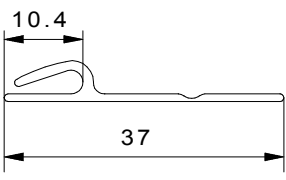
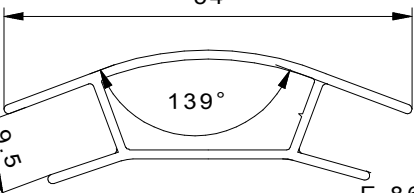
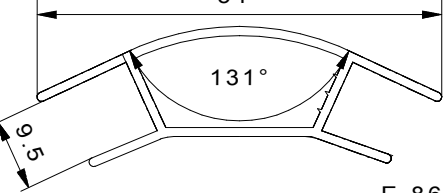
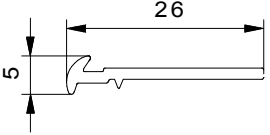
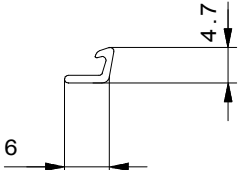
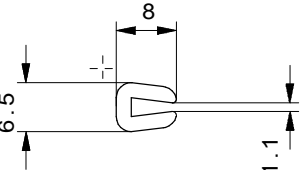
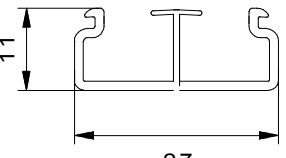
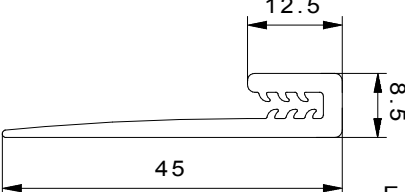
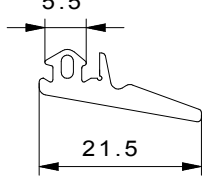
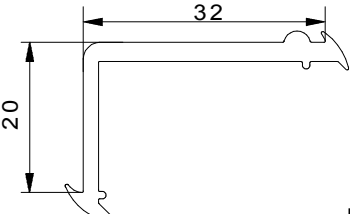
<p>Abdichtprofil</p>  <p>E 794</p>	<p>Scheibendichtung</p>  <p>E 795</p>	<p>Staukastenprofil</p>  <p>E 796</p>
<p>Staukastenprofil</p>  <p>E 797</p>	<p>Stegumleimer</p>  <p>E 798</p>	<p>Wandanschluß</p>  <p>E 799</p>
<p>Unterlegprofil</p>  <p>E 800</p>	<p>Stegumleimer</p>  <p>E 801</p>	<p>Türprofil</p>  <p>E 802</p>
<p>Stegumleimer</p>  <p>E 803</p>	<p>Abdichtprofil</p>  <p>E 804</p>	<p>Anschlagdichtung</p>  <p>E 805</p>
<p>Aufstellband</p>  <p><i>Verkleinert</i></p> <p>E 806</p>	<p>Winkelprofil</p>  <p>E 807</p>	<p>Dachprofil</p>  <p>E 808</p>
<p>Kantenschutz</p>  <p>E 809</p>	<p>Dübelprofil</p>  <p>E 810</p>	<p>Abdeckleiste</p>  <p>E 811</p>
<p>Anschlagdichtung</p>  <p>E 812</p>	<p>Anschlagdichtung</p>  <p>E 813</p>	<p>Stegumleimer</p>  <p>E 814</p>

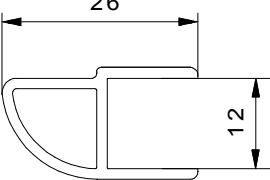
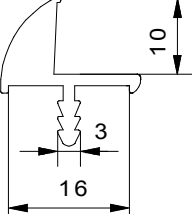
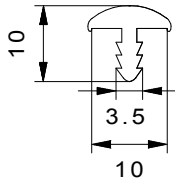
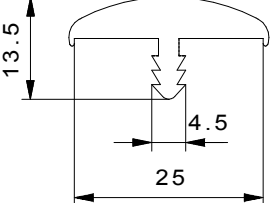
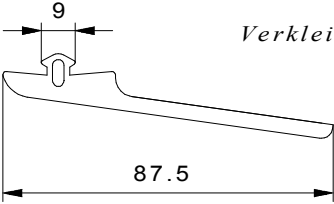

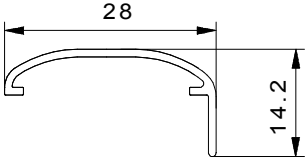
<p>Abdeckprofil <i>Verkleinert</i></p>  <p>E 815</p>	<p>E 816</p>	<p>Flachband</p>  <p>E 817</p>
<p>Dübelprofil</p>  <p>E 818</p>	<p>Glashalteleiste</p>  <p>E 819</p>	<p>Glashalteleiste</p>  <p>E 820</p>
<p>Regenrinne</p>  <p>E 821</p>	<p>Kantenschutz</p>  <p>E 822</p>	<p>Flachprofil <i>Verkleinert</i></p>  <p>E 823</p>
<p>Dichtprofil</p>  <p>E 824</p>	<p>Dichtprofil</p>  <p>E 825</p>	<p>E 826</p>
<p>Hohlbiege <i>Verkleinert</i></p>  <p>E 827</p>	<p>Abdeckprofil</p>  <p>E 828</p>	<p>Nutabdeckprofil</p>  <p>E 829</p>
<p>Unterlegprofil</p>  <p>E 830</p>	<p>Fugenabdeckprofil</p>  <p>E 831</p>	<p>Abdichtprofil <i>Verkleinert</i></p>  <p>E 832</p>
<p>Leistenfüller</p>  <p>E 833</p>	<p>Schutzleiste <i>Verkleinert</i></p>  <p>E 834</p>	<p>Stegumleimer</p>  <p>E 835</p>

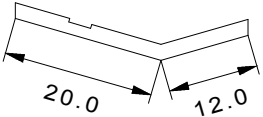
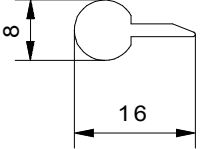
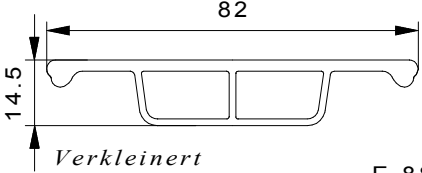
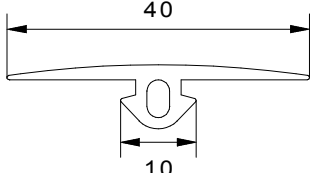
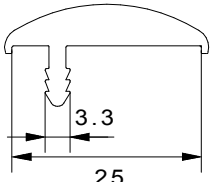
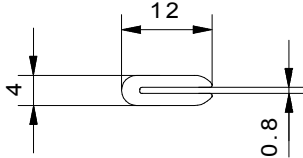
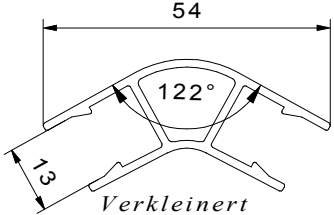
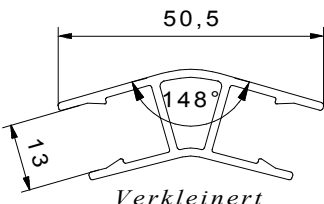
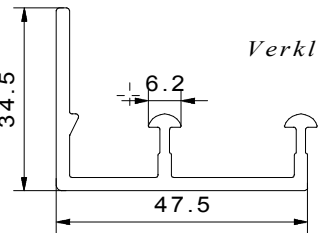
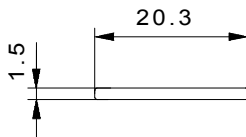
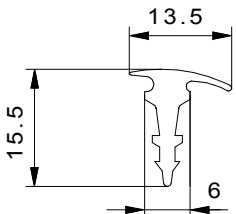
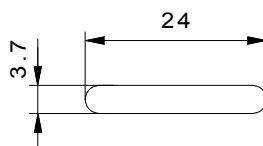
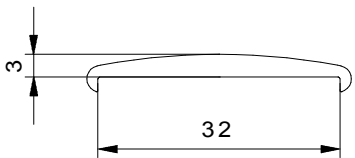
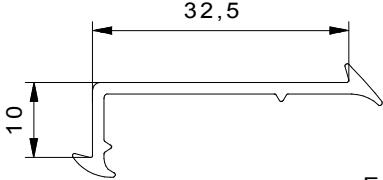
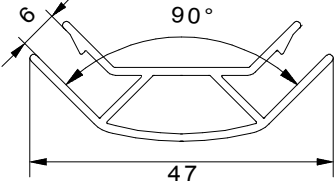
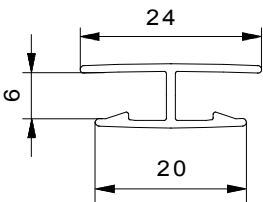
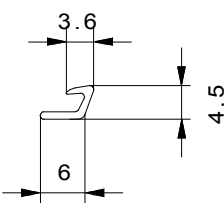
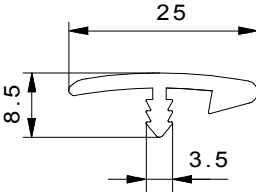
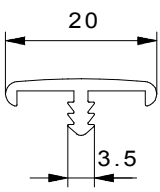

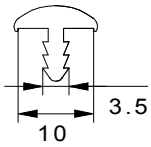
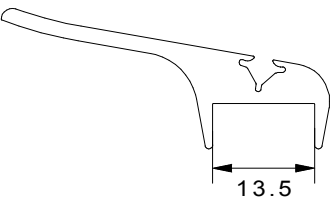
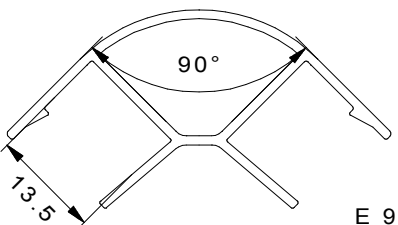
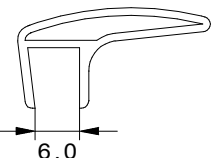
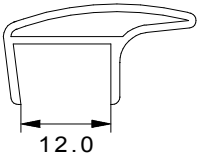
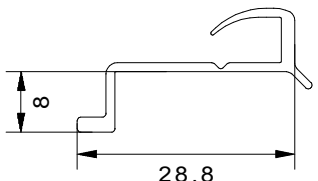
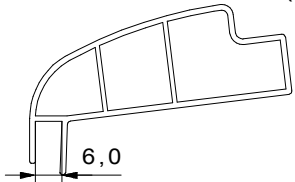
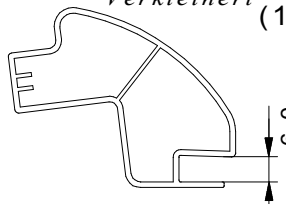
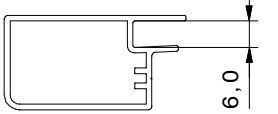
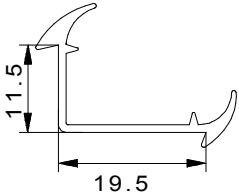
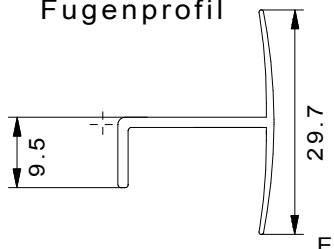
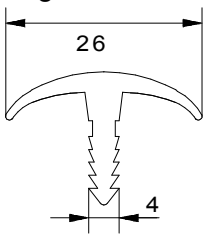
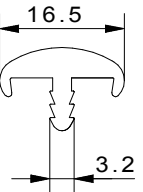
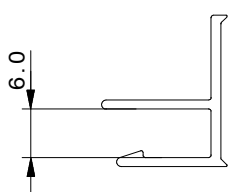
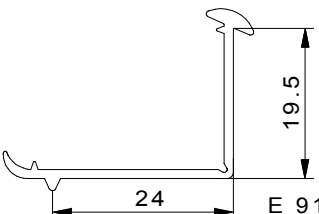

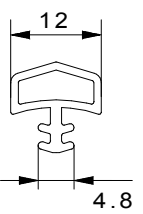
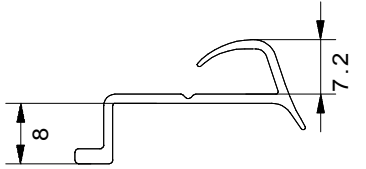
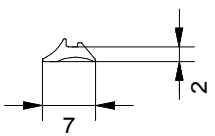
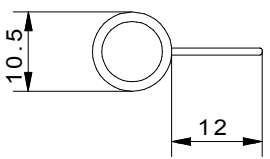
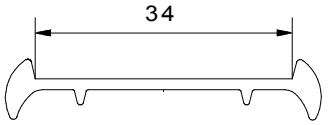
<p>Stegumleimer</p>  <p>E 836</p>	<p>Abschlußprofil</p>  <p>E 837</p>	<p>Abdeckprofil</p>  <p>E 838</p>
<p>Abdeckprofil</p>  <p>E 839</p>	<p>Distanzleiste</p>  <p>E 840</p>	<p>Distanzleiste</p>  <p>E 841</p>
<p>Rundschale</p>  <p><i>Verkleinert</i></p> <p>E 842</p>	<p>Schlauch</p>  <p>E 843</p>	<p>Schlauch</p>  <p>E 844</p>
<p>Einhängekeder</p>  <p>E 845</p>	<p>Halteleiste</p>  <p>E 846</p>	<p>Scharnierleiste</p>  <p>E 847</p>
<p>Abschlußprofil</p>  <p>E 848</p>	<p>Abdeckprofil</p>  <p>E 849</p>	<p>Sonderprofil</p>  <p><i>Verkleinert</i></p> <p>E 850</p>
<p>Nutabdeckung</p>  <p>E 851</p>	<p>Winkelprofil</p>  <p><i>Verkleinert</i></p> <p>E 852</p>	<p>Abschlußprofil</p>  <p>E 853</p>
<p>Abdeckprofil</p>  <p>E 854</p>	<p>Kabelkanal</p>  <p><i>Verkleinert</i></p> <p>E 855</p>	<p>Kabelkanal</p>  <p>E 856</p>

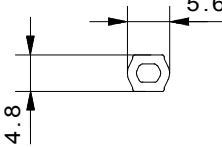
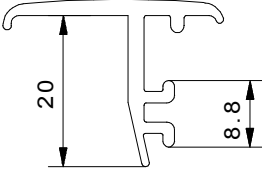
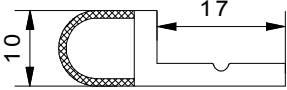
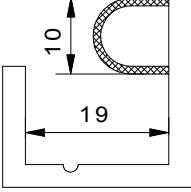
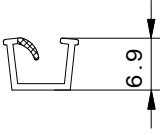
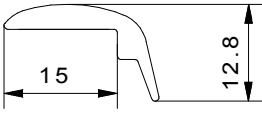
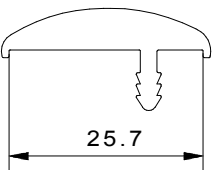
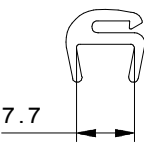
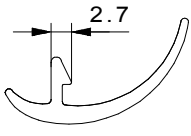
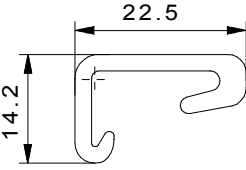
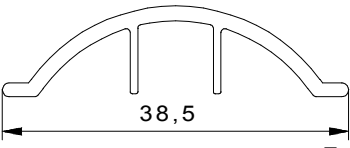

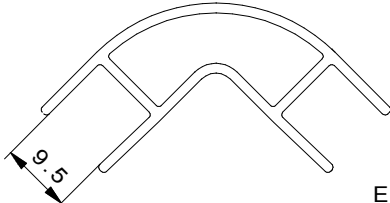
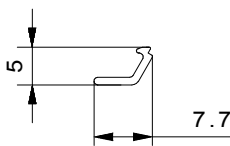
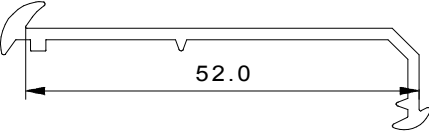
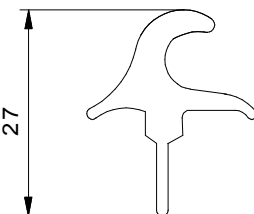
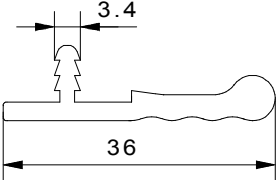
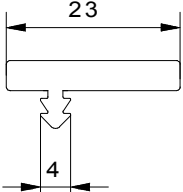
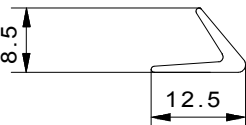
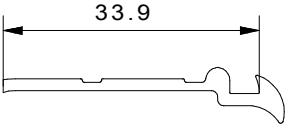
<p>Gurtabdeckung</p>  <p>84</p> <p><i>Verkleinert</i></p> <p>E 857</p>	<p>Eckverbinder 90°</p>  <p>42,5</p> <p>90°</p> <p>9</p> <p>E 858</p>	<p>T-Profil</p>  <p>40</p> <p>19</p> <p>2</p> <p>E 859</p>
<p>Nutabdeckung</p>  <p>34</p> <p>10,5</p> <p>1,5</p> <p>E 860</p>	<p>Abdichtprofil</p>  <p>120</p> <p>6</p> <p><i>Verkleinert</i></p> <p>E 861</p>	<p>Einhängekeder</p>  <p>10,4</p> <p>37</p> <p>E 862</p>
<p>Eckverbinder 139°</p>  <p>54</p> <p>139°</p> <p>5,6</p> <p>E 863</p>	<p>Eckverbinder 131°</p>  <p>54</p> <p>131°</p> <p>5,6</p> <p>E 864</p>	<p>Unterlegprofil</p>  <p>26</p> <p>5</p> <p>E 865</p>
<p>Klapperschutz</p>  <p>4,7</p> <p>6</p> <p>E 866</p>	<p>U-Profil</p>  <p>8</p> <p>6,5</p> <p>1,1</p> <p>E 867</p>	<p>Kabelkanal</p>  <p>11</p> <p>27</p> <p>E 868</p>
<p>Bodenleiste</p>  <p>12,5</p> <p>5,8</p> <p>45</p> <p>E 869</p>	<p>Abdeckprofil</p>  <p>5,5</p> <p>21,5</p> <p>E 870</p>	<p>Winkelprofil</p>  <p>32</p> <p>20</p> <p>E 871</p>
<p>Butylband</p>  <p>E 872</p>	<p>Zierleiste</p>  <p>26</p> <p>12</p> <p>E 873</p>	<p>Stegumleimer</p>  <p>10</p> <p>10</p> <p>3</p> <p>16</p> <p>E 874</p>
<p>Stegumleimer</p>  <p>10</p> <p>3,5</p> <p>10</p> <p>E 875</p>	<p>Stegumleimer</p>  <p>13,5</p> <p>4,5</p> <p>25</p> <p>E 876</p>	<p>Abdeckprofil</p>  <p>9</p> <p><i>Verkleinert</i></p> <p>87,5</p> <p>E 877</p>

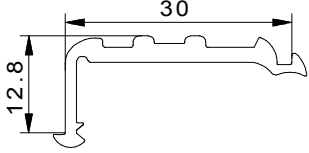
<p>Abdeckleiste</p>  <p>E 878</p>	<p>Anschlagleiste</p>  <p>E 879</p>	<p>Anschlagleiste</p>  <p>E 880</p>
<p>Keder</p>  <p>E 881</p>	<p>Sonderprofil</p>  <p>E 882</p>	<p>Nutabdeckung</p>  <p>E 883</p>
<p>Stegumleimer</p>  <p>E 884</p>	<p>Kantenschutz</p>  <p>E 885</p>	<p>Eckverbinder 122°</p>  <p>E 886</p>
<p>Eckverbinder 148°</p>  <p>E 887</p>	<p>Gardinenschine</p>  <p>E 888</p>	<p>Flachband</p>  <p>E 889</p>
<p>Fugenabdeckung</p>  <p>E 890</p>	<p>Flachband</p>  <p>E 891</p>	<p>Abdeckprofil</p>  <p>E 892</p>
<p>Winkelprofil</p>  <p>E 893</p>	<p>Eckverbinder 90°</p>  <p>E 894</p>	<p>Plattenverbinder</p>  <p>E 895</p>
<p>Klapperschutz</p>  <p>E 896</p>	<p>Stegumleimer</p>  <p>E 897</p>	<p>Stegumleimer</p>  <p>E 898</p>

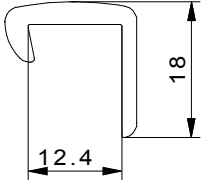
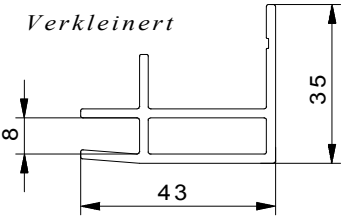
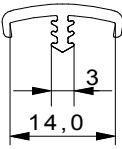
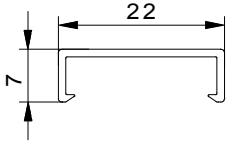
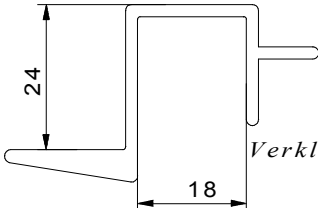
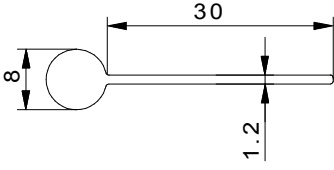
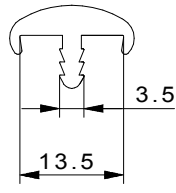
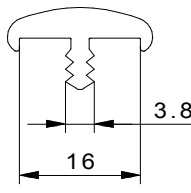
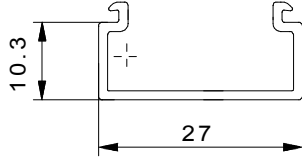
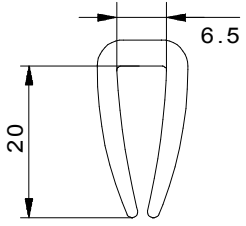
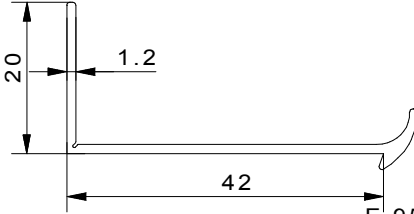
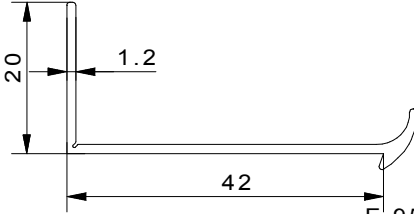
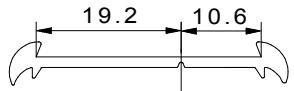

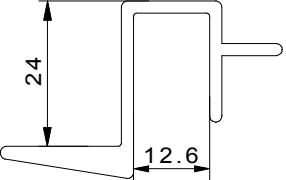
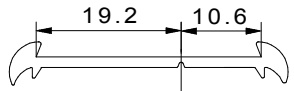
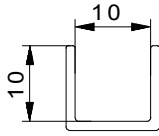
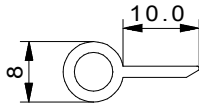
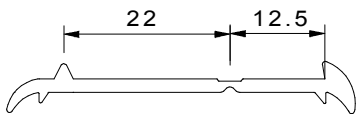

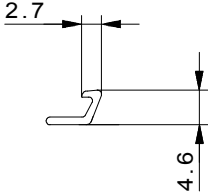
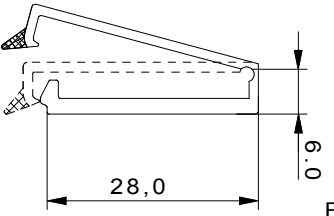
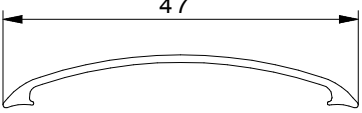
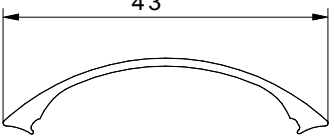
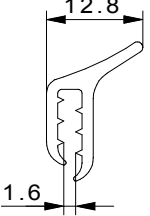
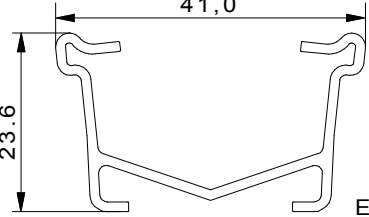
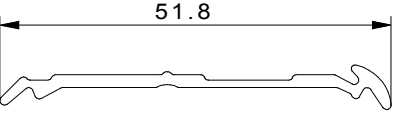
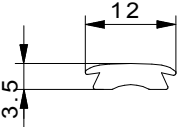
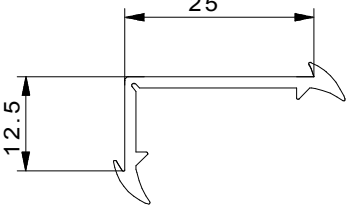
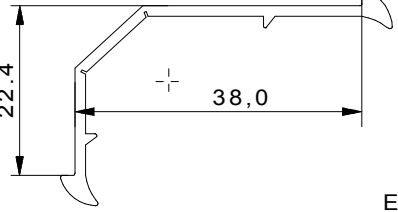
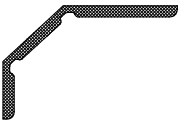
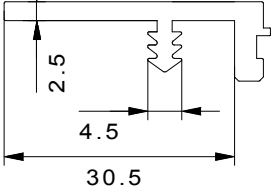
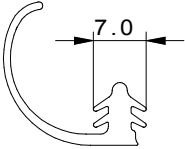
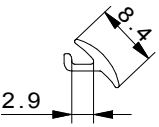
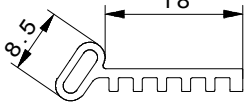
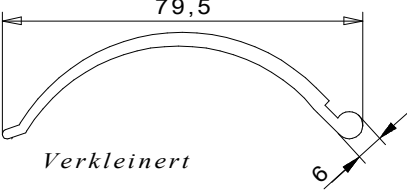
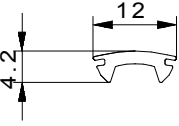
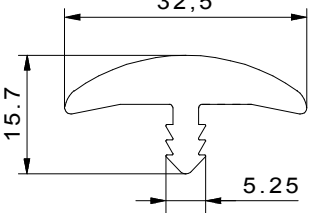
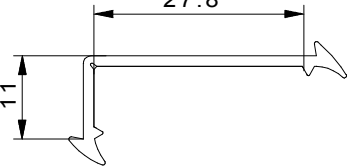
<p>Stegumleimer</p>  <p>E 899</p>	<p>Abdichtprofil</p>  <p>E 900</p>	<p>Eckverbinder 90°</p>  <p>E 901</p>
<p>Ausfallsicherung</p>  <p>E 902</p>	<p>Ausfallsicherung</p>  <p>E 903</p>	<p>Fugenabdeckung</p>  <p>E 904</p>
<p>Möbelleiste <i>Verkleinert (1:2)</i></p>  <p>E 905</p>	<p>Möbelleiste <i>Verkleinert (1:2)</i></p>  <p>E 906</p>	<p>Möbelleiste <i>(1:2) Verkleinert</i></p>  <p>E 907</p>
<p>Winkelprofil</p>  <p>E 908</p>	<p>Fugenprofil</p>  <p>E 909</p>	<p>Stegumleimer</p>  <p>E 910</p>
<p>Stegumleimer</p>  <p>E 911</p>	<p>Wandverbinder</p>  <p>E 912</p>	<p>Winkelprofil</p>  <p>E 913</p>
<p>Butylband</p>  <p>E 914</p>	<p>Zargendichtung</p>  <p>E 915</p>	<p>Fugenabdeckung</p>  <p>E 916</p>
<p>Unterlegprofil</p>  <p>E 917</p>	<p>Hohlbiese</p>  <p>E 918</p>	<p>Unterlegprofil</p>  <p>E 919</p>



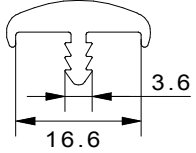
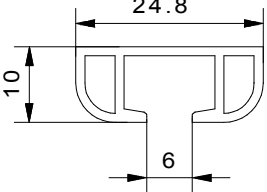
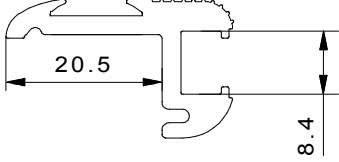
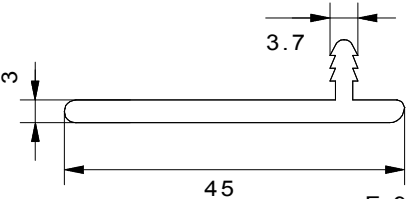
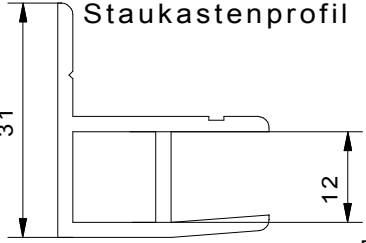
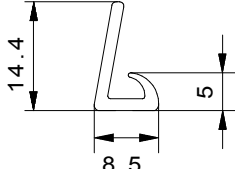
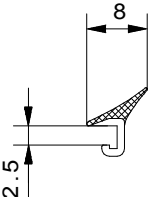
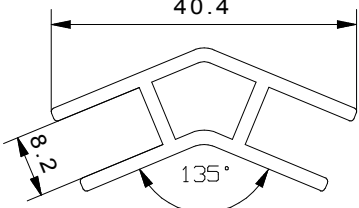
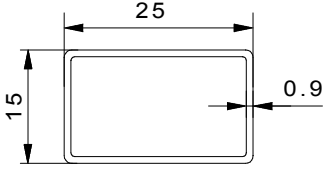
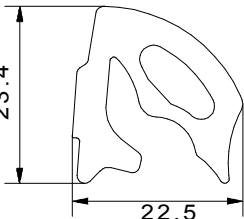
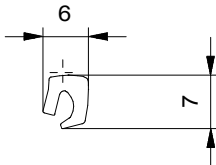
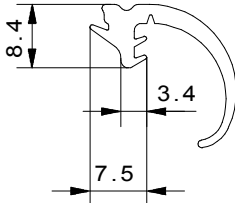
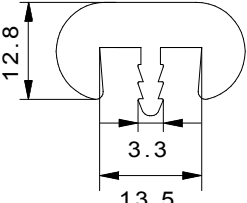
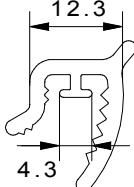
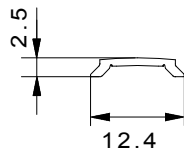
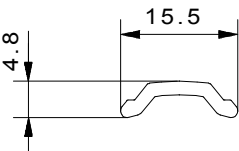
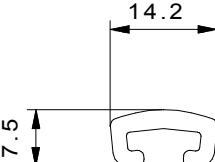
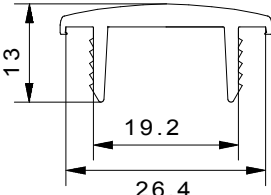
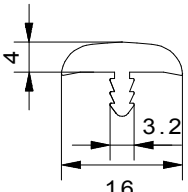
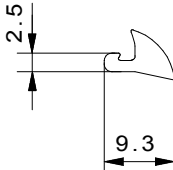
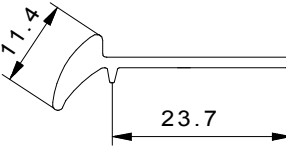

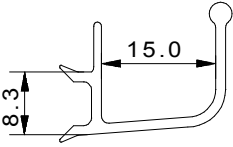
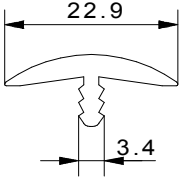
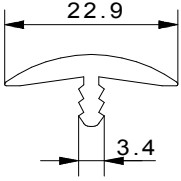
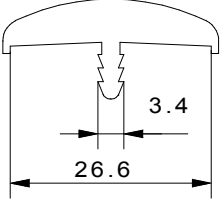
<p>Butylband</p>  <p>E 920</p>	<p>Nutabdeckprofil</p>  <p>E 921</p>	<p>Türprofil</p>  <p>E 922</p>
<p>Anschlagdichtung</p>  <p>E 923</p>	<p>Anschlagdichtung</p>  <p>E 924</p>	<p>Sonderprofil</p>  <p>E 925</p>
<p>Abdichtprofil</p>  <p>E 926</p>	<p>Stegumleimer</p>  <p>E 927</p>	<p>Klemmprofil</p>  <p>E 928</p>
<p>Abdeckprofil</p>  <p>E 929</p>	<p>Kantenschutz</p>  <p>E 930</p>	<p>Leistenfüller</p>  <p>E 931</p>
<p>Butylband</p>  <p>E 932</p>	<p>Eckverbinder 90°</p>  <p>E 933</p>	<p>Klapperschutz</p>  <p>E 934</p>
<p>Winkelprofil</p>  <p>E 935</p>	<p>Regenrinne</p>  <p>E 936</p>	<p>Ausfallsicherung</p>  <p>E 937</p>
<p>Stegumleimer</p>  <p>E 938</p>	<p>Y-Profil</p>  <p>E 939</p>	<p>Unterlegprofil</p>  <p>E 940</p>

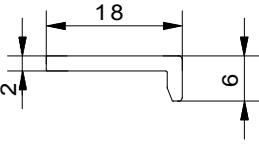
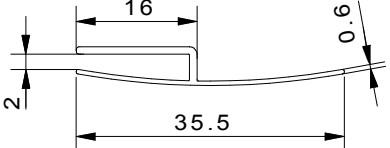
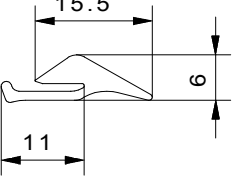
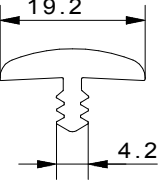
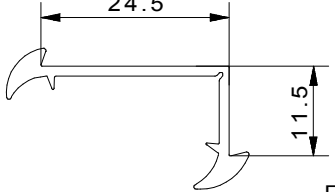
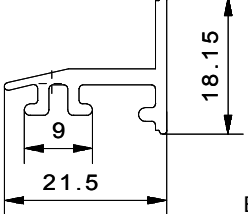
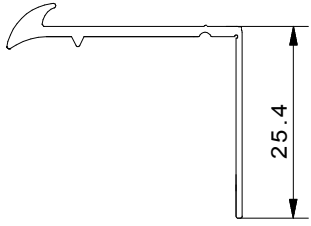
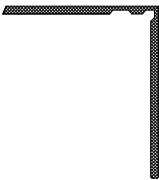
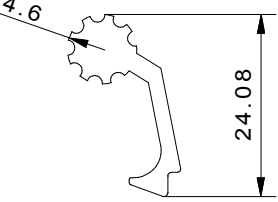
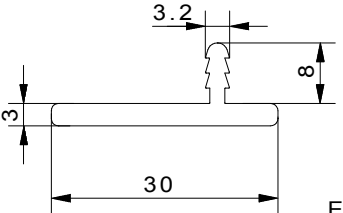
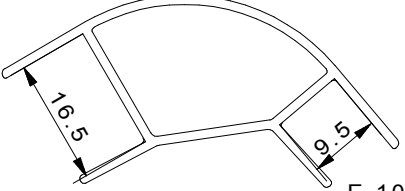
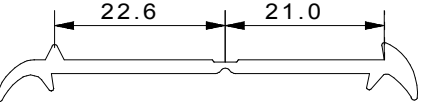

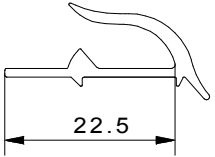
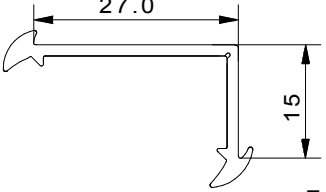
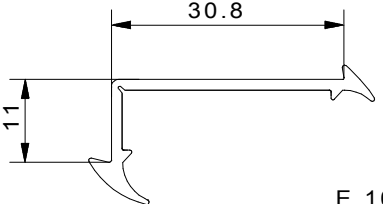

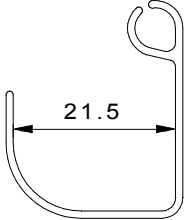
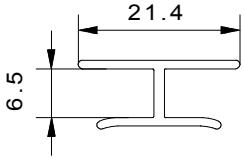
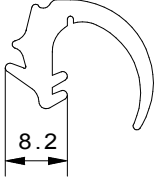
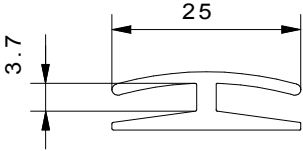

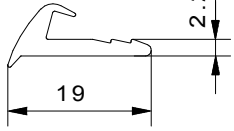
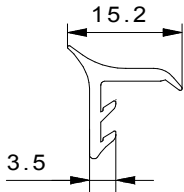
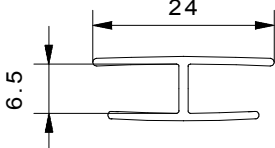
<p>Winkelprofil</p>  <p>E 941</p>	<p>Butylband</p>  <p>E 942</p>	<p>Kantenschutz</p>  <p>E 943</p>
<p>Abstandshalter</p> <p><i>Verkleinert</i></p>  <p>E 944</p>	<p>Stegumleimer</p>  <p>E 945</p>	<p>Isolierschiene</p>  <p>E 946</p>
<p>Tischhalteleiste</p>  <p><i>Verkleinert</i></p> <p>E 947</p>	<p>Keder</p>  <p>E 948</p>	<p>Stegumleimer</p>  <p>E 949</p>
<p>Stegumleimer</p>  <p>E 950</p>	<p>Kabelkanal</p>  <p>E 951</p>	<p>Kantenschutz</p>  <p>E 952</p>
<p>Winkelprofil</p>  <p>E 953</p>	<p>Winkelprofil</p>  <p>E 954</p>	<p>Winkelprofil</p>  <p>E 955</p>
<p>Butylband</p>  <p>E 956</p>	<p>Tischhalteleiste</p>  <p>E 957</p>	<p>Winkelprofil</p>  <p>E 958</p>
<p>Kantenschutz</p>  <p>E 959</p>	<p>Hohlbiese</p>  <p>E 960</p>	<p>Winkelprofil</p>  <p>E 961</p>

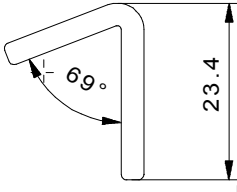
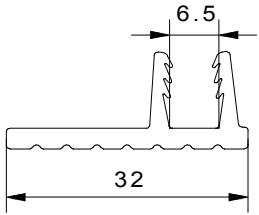
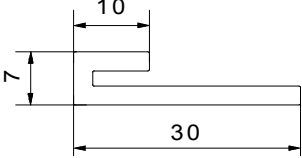
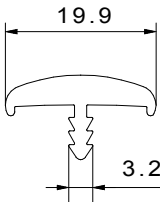
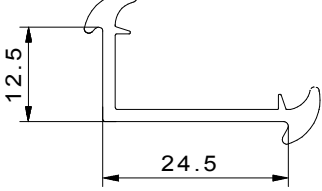
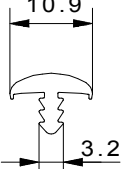
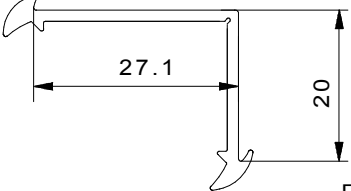
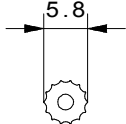
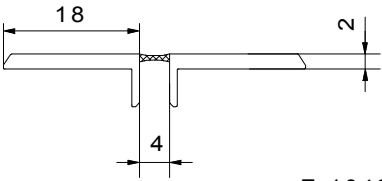
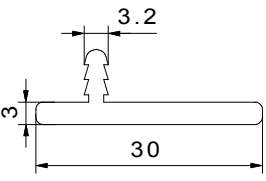
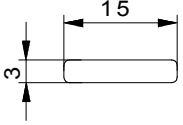
<p>Butylband</p>  <p>E 962</p>	<p>Klapperschutz</p>  <p>E 963</p>	<p>Abdeckprofil</p>  <p>E 964</p>
<p>Abdeckleiste</p>  <p>E 965</p>	<p>Abdeckleiste</p>  <p>E 966</p>	<p>Kantenschutz</p>  <p>E 967</p>
<p>Schutzleiste</p>  <p>E 968</p>	<p>Winkelprofil</p>  <p>E 969</p>	<p>Leistenfüller</p>  <p>E 970</p>
<p>Winkelprofil</p>  <p>E 971</p>	<p>Winkelprofil</p>  <p>E 972</p>	<p>Butylband</p>  <p>E 973</p>
<p>Stegumleimer</p>  <p>E 974</p>	<p>Abdeckprofil</p>  <p>E 975</p>	<p>Unterlegprofil</p>  <p>E 976</p>
<p>Hohlbiese</p>  <p>E 977</p>	<p>Abdichtprofil</p>  <p>E 978</p>	<p>Leistenfüller</p>  <p>E 979</p>
<p>Stegumleimer</p>  <p>E 980</p>	<p>Winkelprofil</p>  <p>E 981</p>	<p>Butylband</p>  <p>E 982</p>

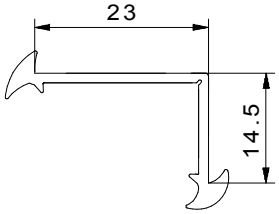
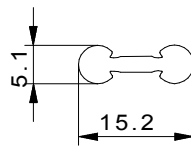
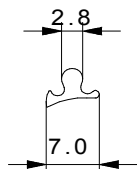
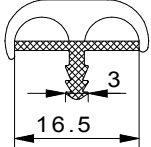
<p>Stegumleimer</p>  <p>E 983</p>	<p>Gardinienschiene</p>  <p>E 984</p>	<p>Einstiegsleiste</p>  <p>E 985</p>
<p>Ausfallsicherung</p>  <p>E 986</p>	<p>Staukastenprofil</p>  <p>E 987</p>	<p>Kantenschutz</p>  <p>E 988</p>
<p>Kantenschutz</p>  <p>E 989</p>	<p>Eckverbinder</p>  <p>E 990</p>	<p>Leerrohr</p>  <p>E 991</p>
<p>Kantenschutz</p>  <p>E 992</p>	<p>Kantenschutz</p>  <p>E 993</p>	<p>Abdeckprofil</p>  <p>E 994</p>
<p>Stegumleimer</p>  <p>E 995</p>	<p>Rolltorprofil</p>  <p>E 996</p>	<p>Leistenfüller</p>  <p>E 997</p>
<p>Leistenfüller</p>  <p>E 998</p>	<p>Kantenschutz</p>  <p>E 999</p>	<p>Kantenumleimer</p>  <p>E 1000</p>
<p>Stegumleimer</p>  <p>E 1001</p>	<p>Unterlegprofil</p>  <p>E 1002</p>	<p>Unterlegprofil</p>  <p>E 1003</p>

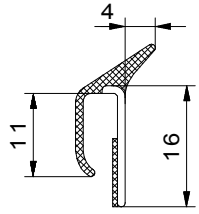

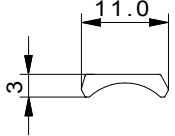

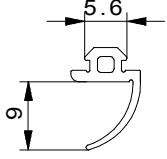
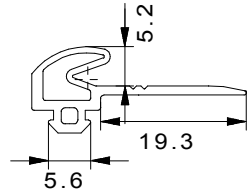
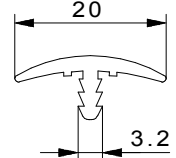
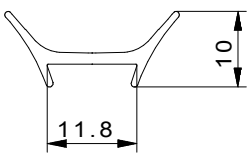
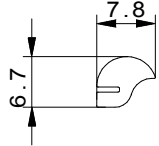
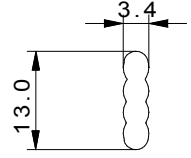
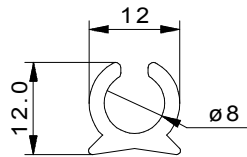
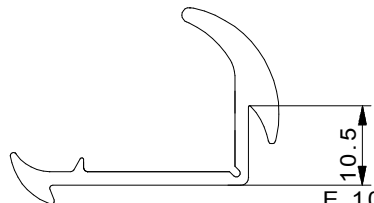
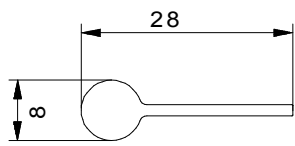
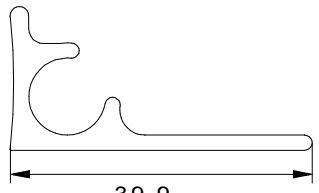
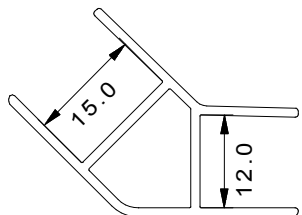
<p>Regenrinne</p>  <p>E 1004</p>	<p>Stegumleimer</p>  <p>E 1005</p>	<p>Stegumleimer</p>  <p>E 1006</p>
<p>Stegumleimer</p>  <p>E 1007</p>	<p>Abdeckprofil</p>  <p><i>Verkleinert</i></p> <p>E 1008</p>	<p>Anschlagprofil</p>  <p>E 1009</p>
<p>Nutabdeckung</p>  <p>E 1010</p>	<p>Kantenabdeckung</p>  <p>E 1011</p>	<p>Stegumleimer</p>  <p>E 1012</p>
<p>Winkelprofil</p>  <p>E 1013</p>	<p>Türprofil</p>  <p>E 1014</p>	<p>Winkelprofil</p>  <p>E 1015</p>
<p>Butylband</p>  <p>E 1016</p>	<p>Scharnierleiste</p>  <p>E 1017</p>	<p>Ausfallsicherung</p>  <p>E 1018</p>
<p>Eckverbinder 100°</p>  <p>E 1019</p>	<p>Winkelprofil</p>  <p>E 1020</p>	<p>Butylband</p>  <p>E 1021</p>
<p>Kantenabdeckung</p>  <p>E 1022</p>	<p>Winkelprofil</p>  <p>E 1023</p>	<p>Winkelprofil</p>  <p>E 1024</p>

<p>Butylband</p>  <p>E 1025</p>	<p>Regenrinne</p>  <p>E 1026</p>	<p>Plattenverbinder</p>  <p>E 1027</p>
<p>Abdeckprofil</p>  <p>E 1028</p>	<p>Plattenverbinder</p>  <p>E 1029</p>	<p>Butylband</p>  <p>E 1030</p>
<p>Fugenabdeckung</p>  <p>E 1031</p>	<p>Wandanschluß</p>  <p>E 1032</p>	<p>Plattenverbinder</p>  <p>E 1033</p>
<p>Butylband</p>  <p>E 1034</p>	<p>Einhängewinkel</p>  <p>E 1035</p>	<p>Ausfallsicherung</p>  <p>E 1036</p>
<p>Kantenschutz</p>  <p>E 1037</p>	<p>Stegumleimer</p>  <p>E 1038</p>	<p>Winkelprofil</p>  <p>E 1039</p>
<p>Stegumleimer</p>  <p>E 1040</p>	<p>Winkelprofil</p>  <p>E 1041</p>	<p>Rundschnur</p>  <p>E 1042</p>
<p>Sonderprofil</p>  <p>E 1043</p>	<p>Ausfallsicherung</p>  <p>E 1044</p>	<p>Flachband</p>  <p>E 1045</p>

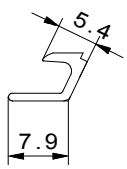
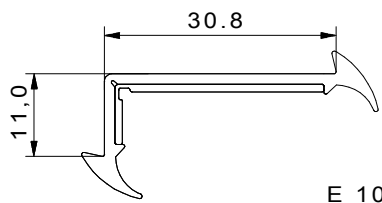
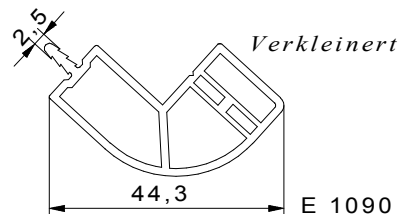
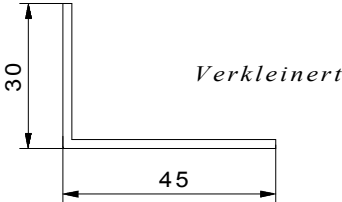
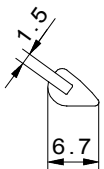
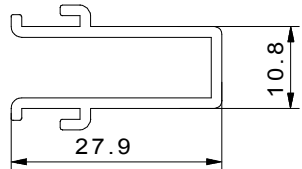
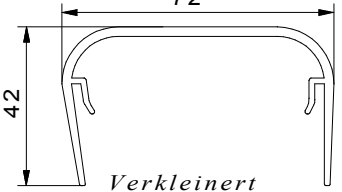
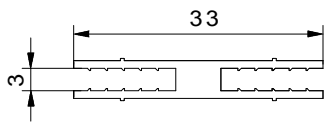
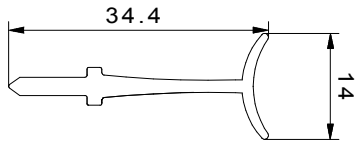
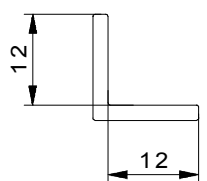
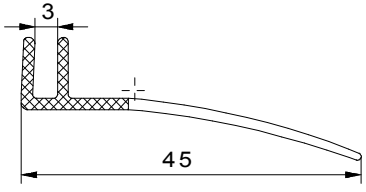
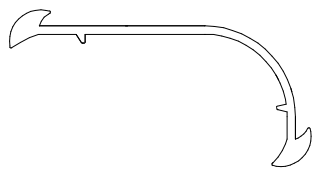
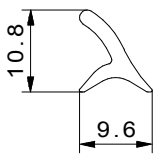
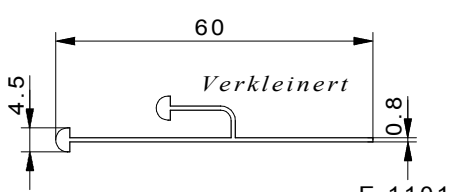
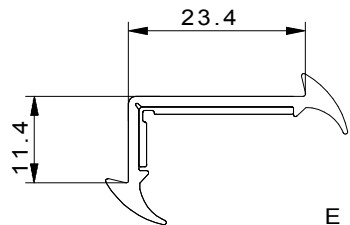
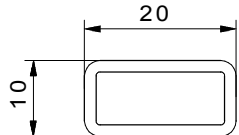
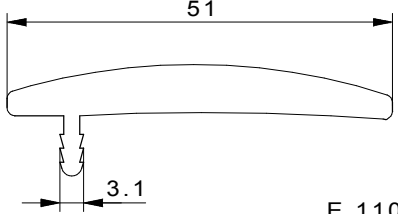
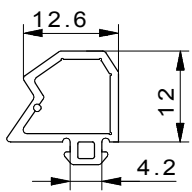
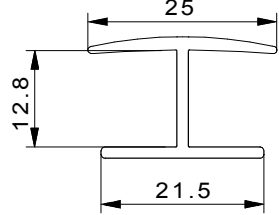
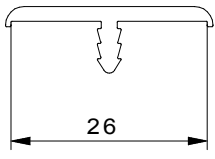
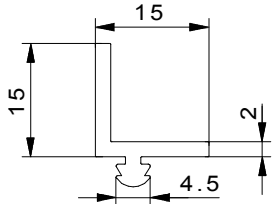

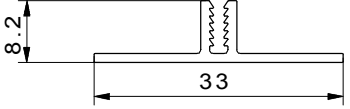
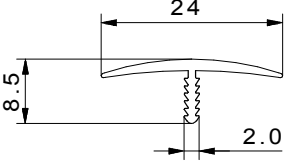
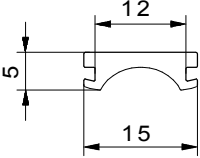
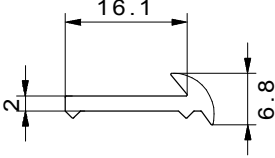
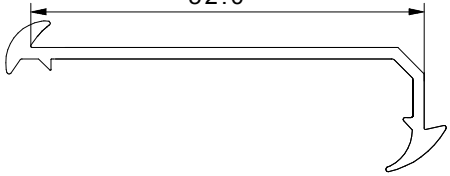
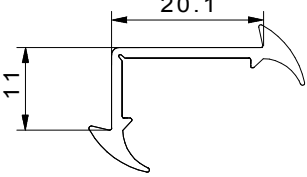
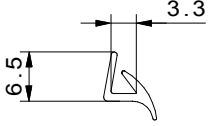
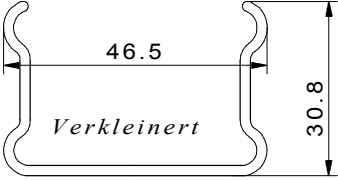
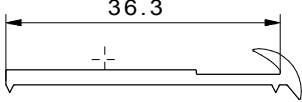
<p>Winkelprofil</p>  <p>E 1046</p>	<p>Doppelkeder</p>  <p>E 1047</p>	<p>Nutfüller</p>  <p>E 1048</p>
<p>Stegumleimer</p>  <p>E 1049</p>	<p>Butylband</p>  <p>E 1050</p>	<p>Kantenabdeckung</p>  <p>E 1051</p>
<p>Butylband</p>  <p>E 1052</p>	<p>Leistenfüller</p>  <p>E 1053</p>	<p>Butylband</p>  <p>E 1054</p>
<p>Zargendichtung</p>  <p>E 1055</p>	<p>Zargendichtung</p>  <p>E 1056</p>	<p>Stegumleimer</p>  <p>E 1057</p>
<p>Abschlußprofil</p>  <p>E 1058</p>	<p>Dichtprofil</p>  <p>E 1059</p>	<p>Relingprofil</p>  <p>E 1060</p>
<p>Kederschiene</p>  <p>E 1061</p>	<p>Winkelprofil</p>  <p>E 1062</p>	<p>Keder</p>  <p>E 1063</p>
<p>Schlauchhalter</p>  <p>E 1064</p>	<p>+</p> <p>E 1065</p>	<p>Eckverbinder</p>  <p>E 1066</p>



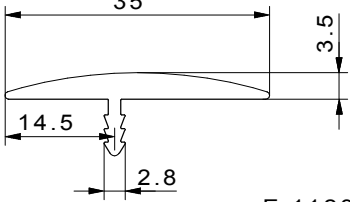
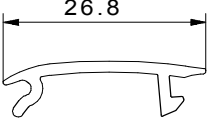
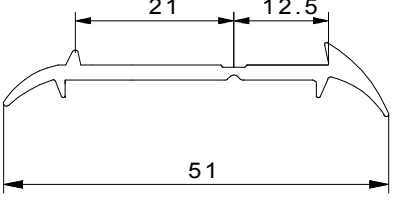
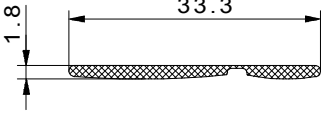
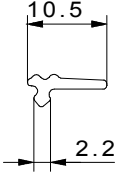
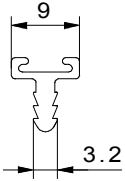

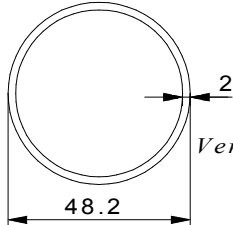
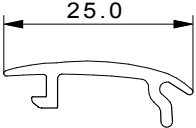
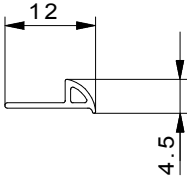
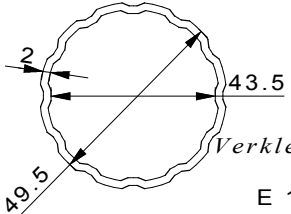
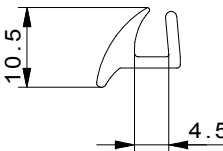
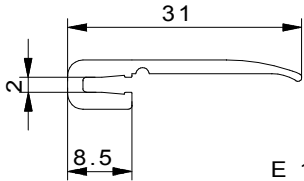
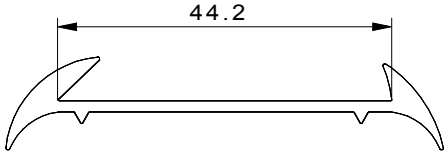
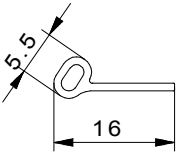
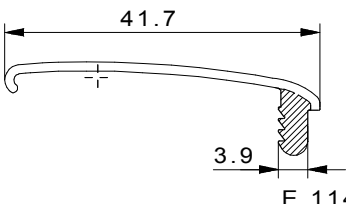
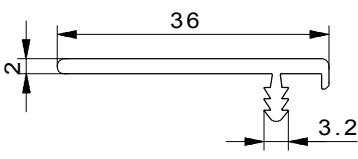
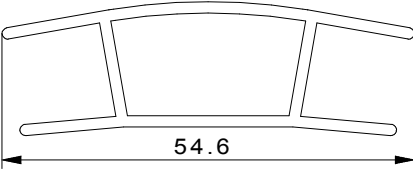
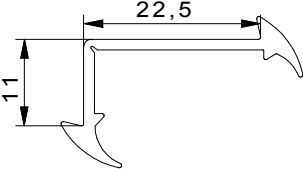
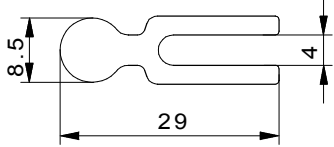
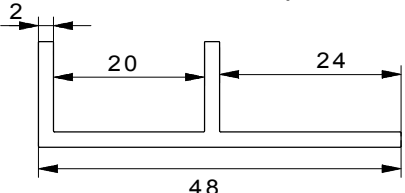
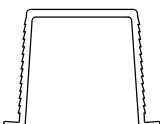
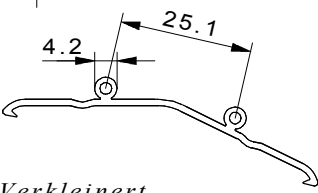
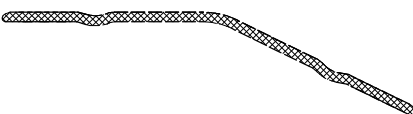
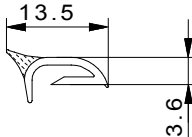
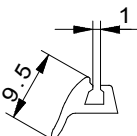

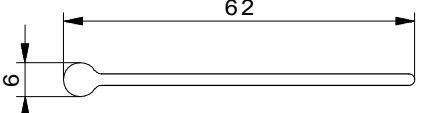
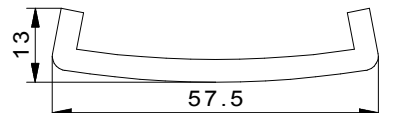
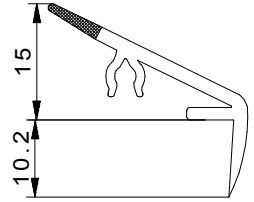
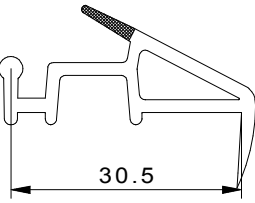
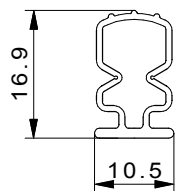
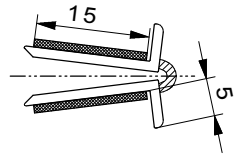
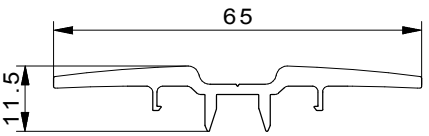
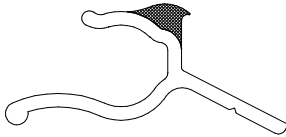
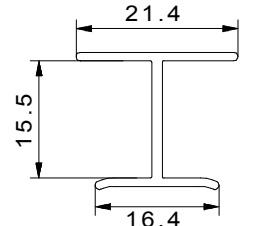
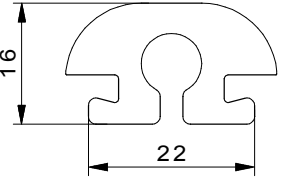
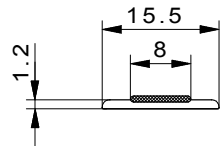
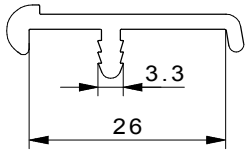
<p>Winkelprofil</p> <p>E 1067</p>	<p>Anschlagdichtung</p> <p>E 1068</p>	<p>Kantenschutz</p> <p>E 1069</p>
<p>Dichtprofil</p> <p>E 1070</p>	<p>Butylband</p> <p>E 1071</p>	<p>Rechteckprofil</p> <p>E 1072</p>
<p>Übergangprofil</p> <p>E 1073</p>	<p>Stegumleimer</p> <p>E 1074</p>	<p>U-Profil</p> <p>E 1075</p>
<p>Kantenschutz</p> <p>E 1076</p>	<p>+</p> <p>+</p>	<p>+</p>
<p>Schlauch</p> <p><i>Verkleinert</i></p> <p>E 1079</p>	<p>+</p>	<p>Einfußprofil</p> <p>E 1081</p>
<p>Unterlegprofil</p> <p>E 1082</p>	<p>Einfußprofil</p> <p>E 1083</p>	<p>Abdeckprofil</p> <p>E 1084</p>
<p>Dichtprofil</p> <p>E 1085</p>	<p>Kantenschutz</p> <p>E 1086</p>	<p>Klapperschutz</p> <p>E 1087</p>

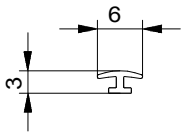
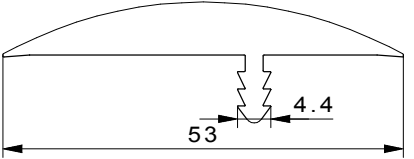
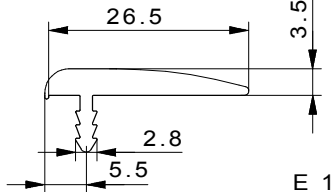
<p>Klapperschutz</p>  <p>E 1088</p>	<p>Winkelprofil</p>  <p>E 1089</p>	<p>Eckverbinder</p>  <p>E 1090</p>
<p>Winkelprofil</p>  <p>E 1091</p>	<p>Kantenabdeckung</p>  <p>E 1092</p>	<p>Scheibeneinfassprofil</p>  <p>E 1093</p>
<p>Displayprofil 72</p>  <p>E 1094</p>	<p>Distanzprofil</p>  <p>E 1095</p>	<p>Abdichtprofil</p>  <p>E 1096</p>
<p>Anschlagprofil</p>  <p>E 1097</p>	<p>Abdichtprofil</p>  <p>E 1098</p>	<p>Winkelprofil</p>  <p>E 1099</p>
<p>Leistenfüller</p>  <p>E 1100</p>	<p>Vorhangkeder</p>  <p>E 1101</p>	<p>Winkelprofil</p>  <p>E 1102</p>
<p>Vierkantrohr</p>  <p>E 1103</p>	<p>Stegumleimer</p>  <p>E 1104</p>	<p>Dichtprofil</p>  <p>E 1105</p>
<p>Plattenverbinder</p>  <p>E 1106</p>	<p>Stegumleimer</p>  <p>E 1107</p>	<p>Anschlagprofil</p>  <p>E 1108</p>

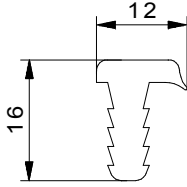
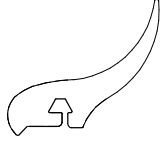
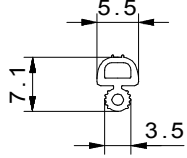
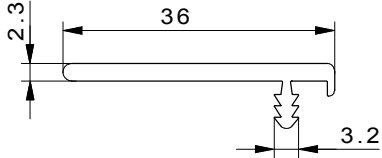
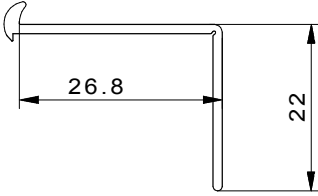
<p>Plattenverbinder</p>  <p>E 1109</p>	<p>Plattenverbinder</p>  <p>E 1110</p>	<p>Leistenfüller</p>  <p>E 1111</p>
<p>Unterlegprofil</p>  <p>E 1112</p>	<p>+</p> <p>E 1113</p>	<p>Winkelprofil</p>  <p>E 1114</p>
<p>+</p> <p>E 1115</p>	<p>Winkelprofil</p>  <p>E 1116</p>	<p>Kantenabdeckung</p>  <p>E 1117</p>
<p>Schutzleiste</p>  <p>E 1118</p>	<p>Unterlegprofil</p>  <p>E 1119</p>	<p>Butylband</p>  <p>E 1120</p>
<p>Butylband</p>  <p>E 1121</p>	<p>Butylband</p>  <p>E 1122</p>	<p>Stegumleimer</p>  <p>E 1123</p>
<p>Leistenfüller Hart-PVC</p>  <p>E 1124</p>	<p>Winkelprofil</p>  <p>E 1125</p>	<p>Butylband</p>  <p>E 1126</p>
<p>Leistenfüller</p>  <p>E 1127</p>	<p>Bürstenprofil</p>  <p>E 1128</p>	<p>+</p> <p>E 1129</p>

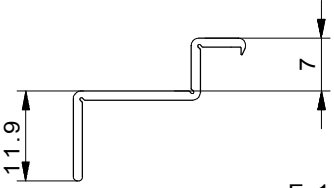
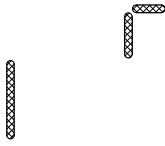
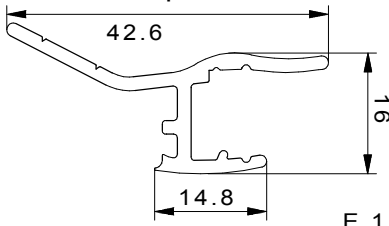
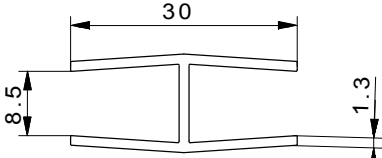
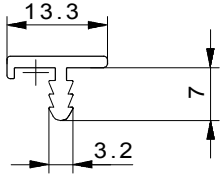
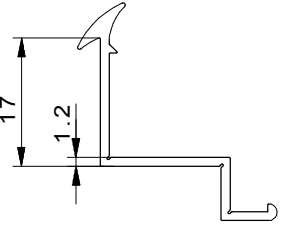
<p>Butylband</p>  <p>E 1130</p>	<p>+</p> <p>E 1131</p>	<p>Schlauch</p>  <p>48.2</p> <p>2</p> <p><i>Verkleinert</i></p> <p>E 1132</p>
<p>Leistenfüller Hart-PVC</p>  <p>25.0</p> <p>E 1133</p>	<p>Hohlbiege</p>  <p>12</p> <p>4.5</p> <p>E 1134</p>	<p>Schlauch</p>  <p>2</p> <p>43.5</p> <p><i>Verkleinert</i></p> <p>E 1135</p>
<p>Unterlegprofil</p>  <p>10.5</p> <p>4.5</p> <p>E 1136</p>	<p>Abdeckprofil</p>  <p>31</p> <p>2</p> <p>8.5</p> <p>E 1137</p>	<p>Unterlegprofil</p>  <p>44.2</p> <p>E 1138</p>
<p>Hohlbiege</p>  <p>5.5</p> <p>16</p> <p>E 1139</p>	<p>Abdeckprofil</p>  <p>41.7</p> <p>3.9</p> <p>E 1140</p>	<p>Stegumleimer</p>  <p>36</p> <p>2</p> <p>3.2</p> <p>E 1141</p>
<p>Eckverbinder 160°</p>  <p>54.6</p> <p>E 1142</p>	<p>Winkelprofil</p>  <p>22,5</p> <p>11</p> <p>E 1143</p>	<p>Keder</p>  <p>8.5</p> <p>29</p> <p>4</p> <p>E 1144</p>
<p>Schiebetürprofil</p>  <p>2</p> <p>20</p> <p>24</p> <p>48</p> <p>E 1145</p>	<p>+</p>  <p>E 1146</p>	<p>+</p>  <p>4.2</p> <p>25.1</p> <p><i>Verkleinert</i></p> <p>E 1147</p>
<p>+</p>  <p>E 1148</p>	<p>+</p>  <p>13.5</p> <p>3.6</p> <p>E 1149</p>	<p>+</p>  <p>9.5</p> <p>1</p> <p>E 1150</p>

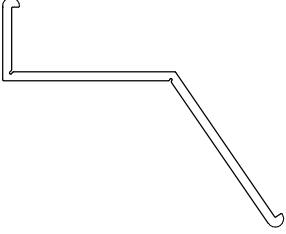
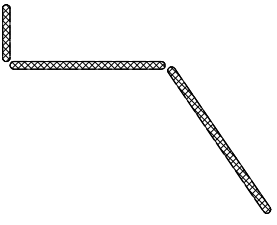
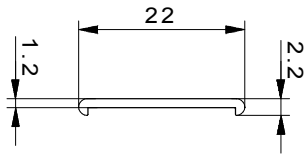
<p>Keder</p>  <p><i>Verkleinert</i> E 1151</p>	<p>Abdeckprofil</p>  <p><i>Verkleinert</i> E 1152</p>	<p>Glashalteprofil</p>  <p>E 1153</p>
<p>Glashalteprofil</p>  <p>E 1154</p>	<p>Dichtprofil</p>  <p>E 1155</p>	<p>Sonderprofil</p>  <p>E 1156</p>
<p>Abdeckprofil</p>  <p><i>Verkleinert</i> E 1157</p>	<p>Lampenhalter</p>  <p>E 1158</p>	<p>+</p> <p>E 1159</p>
<p>Plattenverbinder</p>  <p>E 1160</p>	<p>+</p> <p>+</p> <p>E 1161</p>	<p>+</p> <p>E 1162</p>
<p>Rammschutz</p>  <p>E 1163</p>	<p>+</p>  <p>E 1164</p>	<p>Stegumleimer</p>  <p>E 1165</p>
<p>Butylband</p>  <p>E 1166</p>	<p>Dämpfungsprofil</p>  <p>E 1167</p>	<p>+</p> <p>E 1168</p>
<p>+</p> <p>E 1169</p>	<p>Stegumleimer</p>  <p>E 1170</p>	<p>Stegumleimer</p>  <p>E 1171</p>

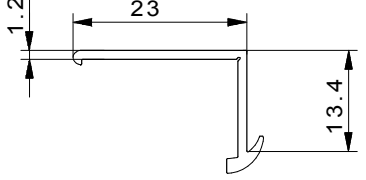
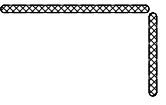
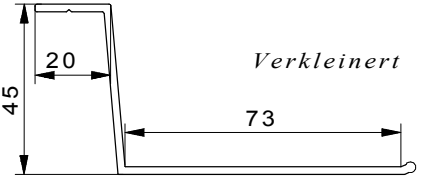
<p>Dichtprofil</p>  <p>E 1172</p>	<p>Abdichtprofil</p>  <p>E 1173</p>	<p>Dichtprofil</p>  <p>E 1174</p>
<p>Stegumleimer</p>  <p>E 1175</p>	<p>Winkelprofil</p>  <p>E 1176</p>	<p>Butylband</p>  <p>E 1177</p>
<p>Winkelprofil</p>  <p>E 1178</p>	<p>Butylband</p>  <p>E 1179</p>	<p>Lampenhalter</p>  <p>E 1180</p>
<p>Plattenverbinder</p>  <p>E 1181</p>	<p>Stegumleimer</p>  <p>E 1182</p>	<p>Winkelprofil</p>  <p>E 1183</p>
<p>Butylband</p>  <p>E 1184</p>	<p>Winkelprofil</p>  <p>E 1185</p>	<p>Butylband</p>  <p>E 1186</p>
<p>Unterlegprofil</p>  <p>E 1187</p>	<p>Butylband</p>  <p>E 1188</p>	<p>Winkelprofil</p>  <p>E 1189</p>
<p>Butylband</p>  <p>E 1190</p>	<p>Kabelabdeckung</p>  <p>E 1191</p>	<p>+</p> <p>E 1192</p>