

# SEFAR® PHARMA GMP solutions

Life Science

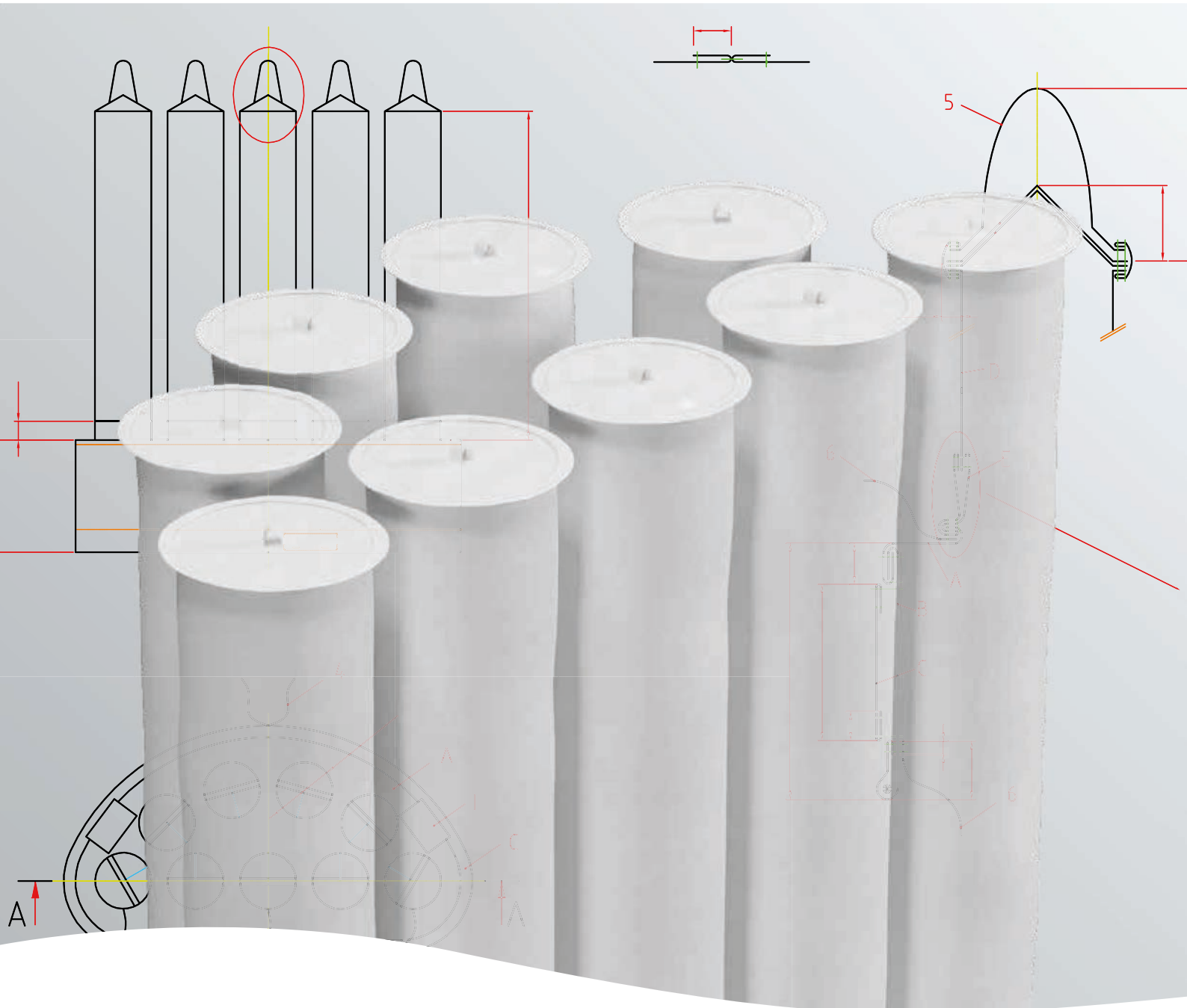

**S E F A R**  
■ ■ ■ ■

# Sefar Life Science Solutions

Sefar responded to the stringent requirements of the pharmaceutical industry by creating the highest quality standards available. Developed in partnership with the world's top pharmaceutical manufacturers SEFAR® PHARMA GMP products represent the highest level of security available on the market today.



## **Specially made for life science industries**

Sefar controls every crucial production step from yarn production to the ready-to-use filters making possible a complete traceability of all critical parts. Our unique market position enables us to supply products to our customers that meet all required quality levels and compliances.



Sefar has perfected its manufacturing processes to meet the needs of the pharmaceutical industry. Our exclusive GMP compliant filter products are manufactured in our cleanroom following strict GMP guidelines.

	Available quality levels		
	PHARMA GMP	PHARMA	Standard
<b>Food and Drug conformity for complete filter</b>	✓	✗	✗
FDA and EC regulation compliance for all components	✓	✗	✗
All production processes and fabrication according to EC 2023/2006 or corresponding cGMP	✓	✗	✗
Fabrication processes in dedicated cleanroom (GMP class D or ISO class 8)	✓	✗	✗
<b>Food and drug conformity for filter media</b>	✓	✓	✗
Tested for extractables and migration values according to EC 10/2011	✓	✓	✗
<b>Food and drug conformity for filter media polymers</b>	✓	✓	✓
ISO 9001 Quality control procedures	✓	✓	✓
Dedicated sales staff, including on-site sales support	✓	✓	✓
Products backed by engineering support staff	✓	✓	✓
PHARMA labels (where applicable)	✓	optional	optional
Conductivity certificate for complete filter (where applicable)	✓	optional	optional



# Fluid Bed Dryer Bags

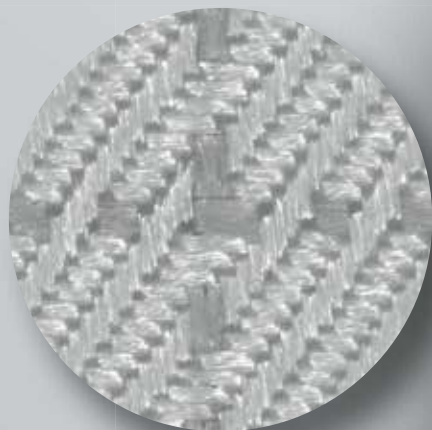

## The industry reference fabric choice

SEFAR **TETEX® MULTI**

- Conductive fabrics
- Best retention at highest permeability



## All skirt options available for easy installation

- Cord
- Zipper







**Caps tailor made to fit your requirements**



**Sefar unique welding technology**

No particle loss through stitching holes



**Sefar unique label technology**

- Excellent identification and traceability
- Customer defined text
- No contamination
- No fading and shedding

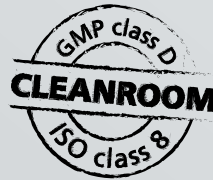

EC 1935/2004	✓
EC 10/2011	✓
GMP EC 2023/2006 or cGMP	✓
FDA CFR 177	✓
ISO 9001	✓
Conductivity tested	✓
Single packaging	✓
Customized labeling	✓
Traceability	✓

	Material	Antistatic	Air permeability [cfm]	Air permeability [l/(m <sup>2</sup> · s)]	Air permeability [l/(dm <sup>2</sup> · min)]	Weight [g/m <sup>2</sup> ]
<b>03-110-168 WA PHARMA</b>	PA	✓	13,8	110	66	168
<b>07-65-180 WA PHARMA</b>	PET	✓	8,1	65	39	180
<b>07-100-150 WA PHARMA</b>	PET	✓	12,5	100	60	150
<b>07-200-150 WA PHARMA</b>	PET	✓	25,0	200	120	150
<b>07-300-150 WA PHARMA</b>	PET	✓	37,5	300	180	150
<b>07-430-140 WA</b>	PET	✓	53,8	430	258	140

# Filter Bags

The certified filter bag solution

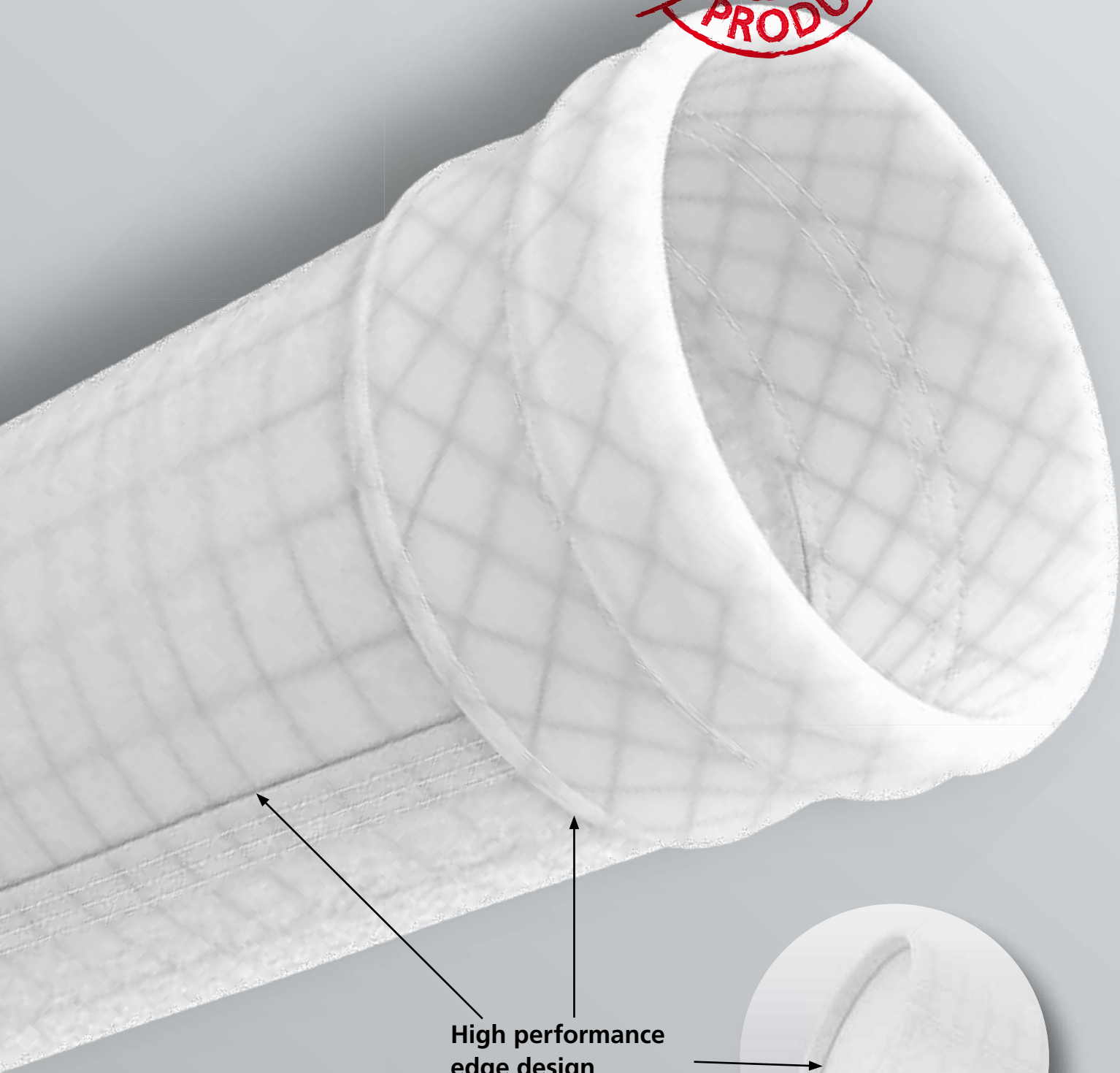

**High performance  
edge design**

to avoid product contamination  
from needle felt fibres

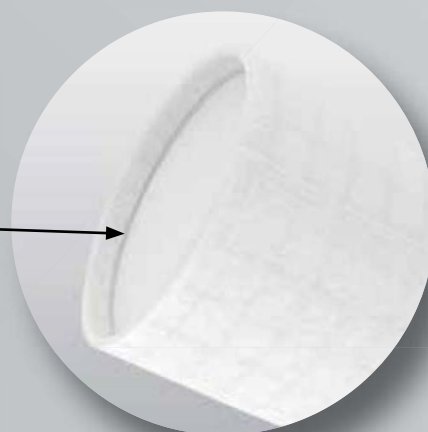

**High conductivity stainless steel matrix**

to provide excellent protection against explosion

**ePTFE membrane**

to avoid contamination and provide high filtration efficiency

**PET or PTFE scrim**

for high mechanical resistance and stability

**EC compliant polyester or PTFE needle felt**

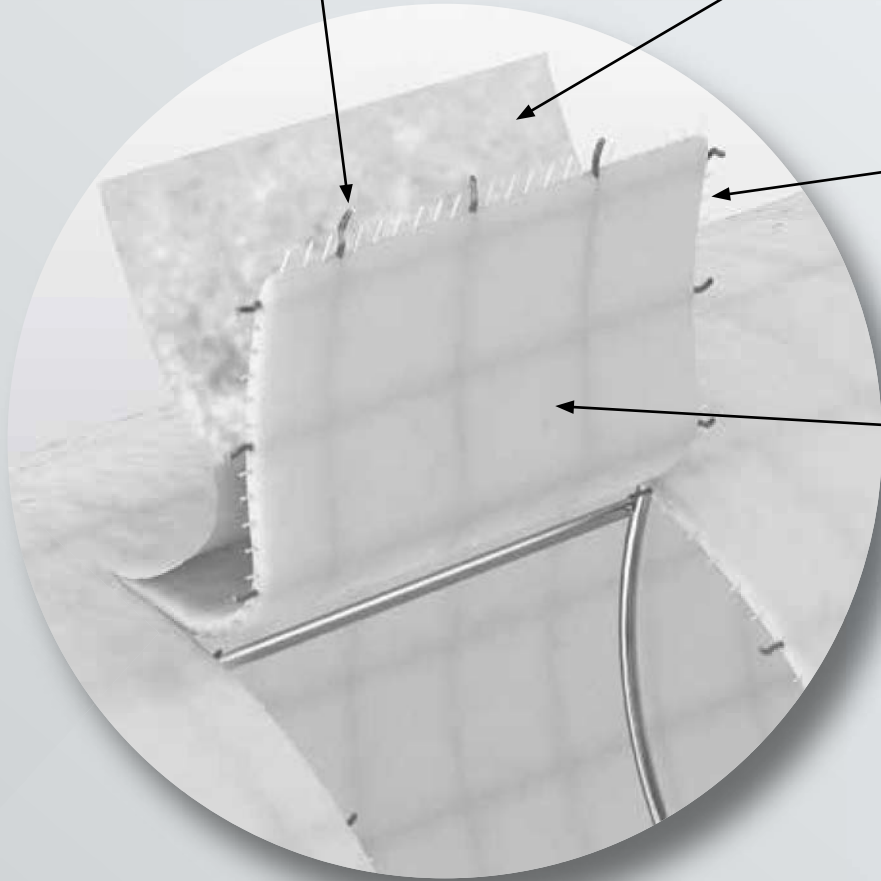

EC 1935/2004	✓
EC 10/2011	✓
GMP EC 2023/2006 or cGMP	✓
FDA CFR 177	✓
ISO 9001	✓
ATEX (EC 94/9)	✓
Single packaging	✓
Customized labeling	✓
Traceability	✓
Test report	✓

	Material	PTFE Membrane	Antistatic	Weight [g/m <sup>2</sup> ]
<b>NEW</b> 07-400-50 NFMA PHARMA	PET	✓	✓	400
07-550-50 NFMA PHARMA	PET	✓	✓	550
07-550-50 NFM PHARMA	PET	✓	-	550
24-750-50 NFM PHARMA	PTFE	✓	-	750

# Centrifuge Bags

**Excellent mechanical  
resistance and easy  
installation**

Sefar unique fabric design

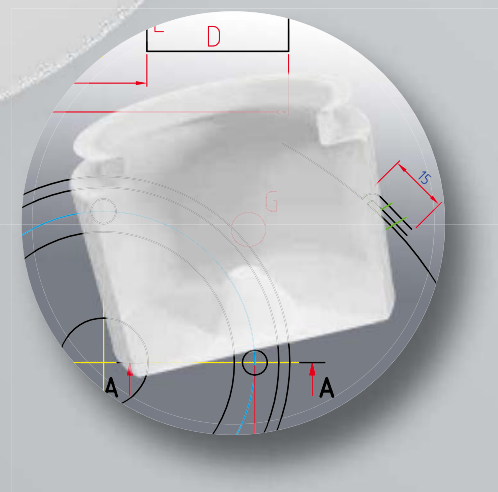

**Customized design  
to fit your equipment**





## The industry reference fabric choice

### SEFAR® TETEX DLW

- Best particle retention
- Best cake release
- Reduced installation and maintenance time



## Sefar unique label technology

- Excellent identification and traceability
- No contamination
- No fading
- No shedding

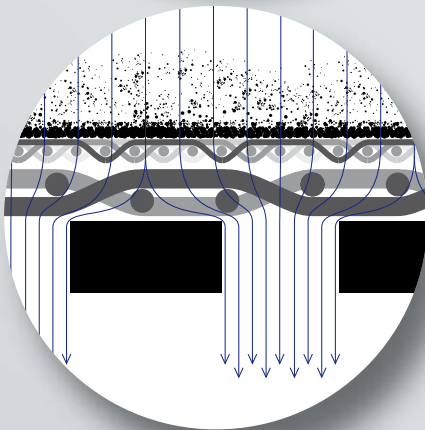

## DLW integrated drainage layer

Improved production capacity



EC 1935/2004	✓
EC 10/2011	✓
GMP EC 2023/2006 or cGMP	✓
FDA CFR 177	✓
ISO 9001	✓
Single packaging	✓
Labeling options	✓
Traceability	✓

	Material	Air permeability [cfm]	Air permeability [l/(m <sup>2</sup> · s)]	Air permeability [l/(dm <sup>2</sup> · min)]	Nominal pore size [µm]	Weight [g/m <sup>2</sup> ]
05-8000-SK 007 PHARMA	PP	3,8	30	18	7	420
05-8000-SK 008 PHARMA	PP	5,0	40	24	8	420
05-8000-SK 012 PHARMA	PP	6,3	50	30	12	455
05-8000-K 020 PHARMA	PP	12,5	100	60	20	425
05-8000-SK 030 PHARMA	PP	25,0	200	120	30	440
05-8000-K 050 PHARMA	PP	50,0	400	240	50	440
05-8000-K 085 PHARMA	PP	75,0	600	360	85	440
05-8000-W 120 PHARMA	PP	212,5	1700	1020	120	425
17-8000-SK 008 PHARMA	PEEK	5,6	45	27	8	586
17-8000-SK 020 PHARMA	PEEK	12,5	100	60	20	586
17-8000-K 040 PHARMA	PEEK	37,5	300	180	40	586
17-8000-SK 085 PHARMA	PEEK	100,0	800	480	85	512

# Inverting Centrifuge Bags

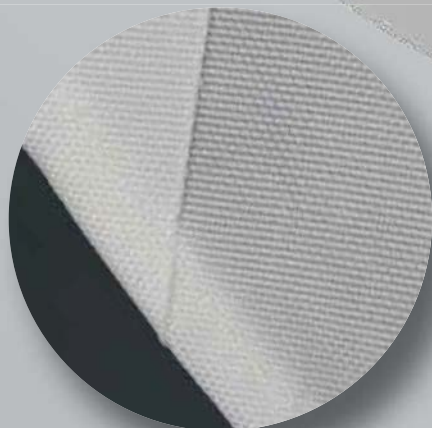
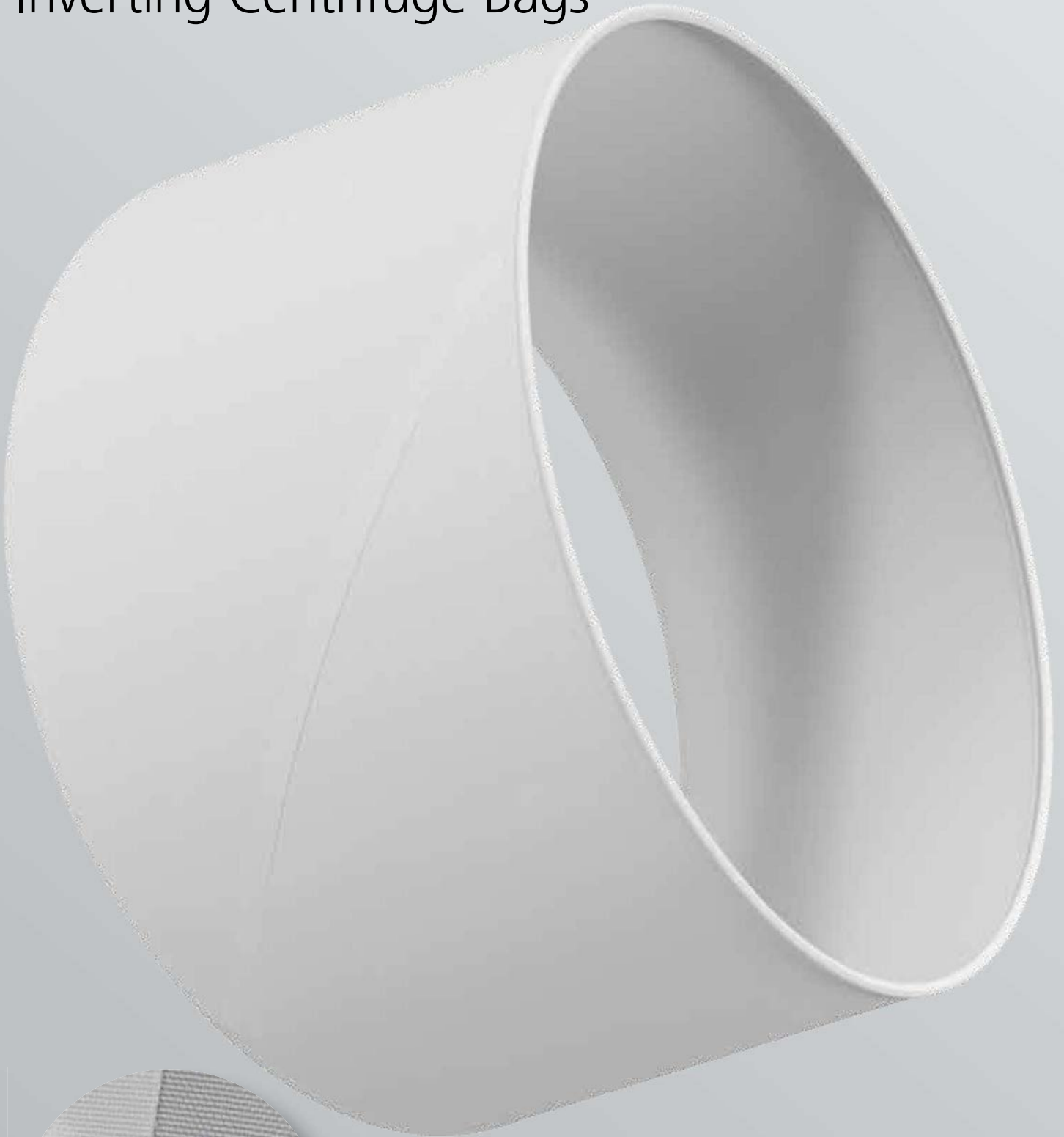

## **Sefar unique welding technology**

No particle loss through stitching holes



## The industry reference fabric choice

### SEFAR **TETEX® MULTI**

- Maximal particle retention
- Good strength
- Flexibility



## Sefar unique marking technology

- Excellent identification and traceability
- No contamination
- No fading
- No shedding

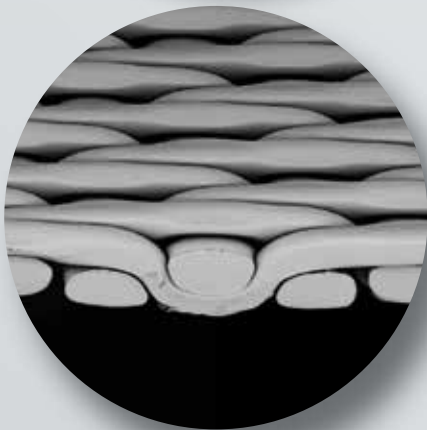

### SEFAR **TETEX® MONO**

- Maximal particle retention with maximal permeability
- Optimal cleaning properties

EC 1935/2004	✓
EC 10/2011	✓
GMP EC 2023/2006 or cGMP	✓
FDA CFR 177	✓
ISO 9001	✓
Single packaging	✓
Customized marking	✓
Traceability	✓



	Material	Air permeability [cfm]	Air permeability [l/(m <sup>2</sup> · s)]	Air permeability [l/(dm <sup>2</sup> · min)]	Nominal pore size [µm]	Weight [g/m <sup>2</sup> ]
Monofilament fabric						
<b>05-1001-SK 025</b>	PP	3,8	30	18	25	272
<b>05-1100-SK 014 PHARMA</b>	PP	12,5	100	60	14	136
<b>05-1050-SK 025 PHARMA</b>	PP	11,9	95	57	25	210
Multifilament fabric						
<b>05-4-660 K PHARMA</b>	PP	0,5	4	2,4	–	660
<b>05-11-360 SK PHARMA</b>	PP	1,4	11	6,6	–	360
<b>05-12-330 W PHARMA</b>	PP	1,5	12,5	7,5	–	320
<b>05-22-300 W PHARMA</b>	PP	2,8	22	13,2	–	300
<b>17-10-240 K PHARMA</b>	PEEK	1,3	10	6	–	235
<b>17-25-240 W PHARMA</b>	PEEK	3,1	25	15	–	235

# Centrifuge Liner

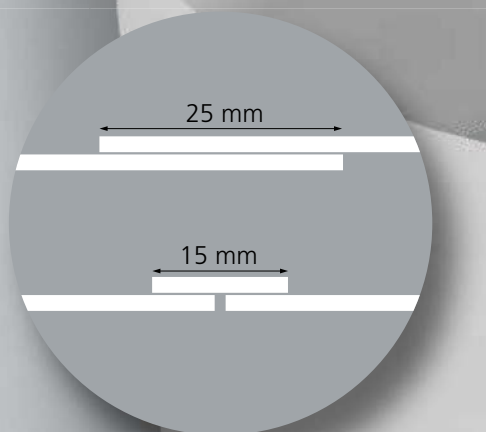
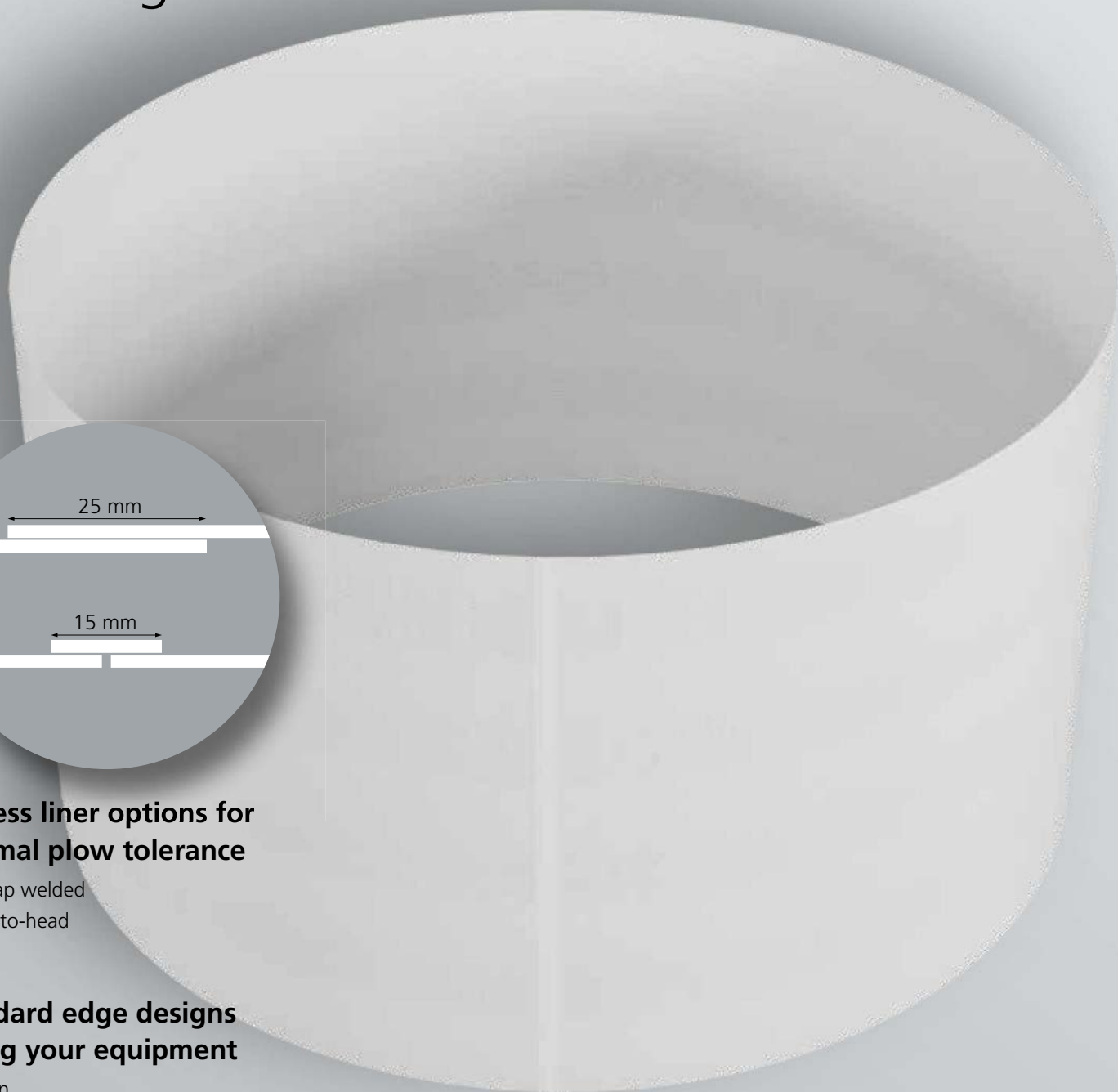

## Endless liner options for minimal plow tolerance

- Overlap welded
- Head-to-head

## Standard edge designs fitting your equipment

- Ribbon
- Taped
- Cut

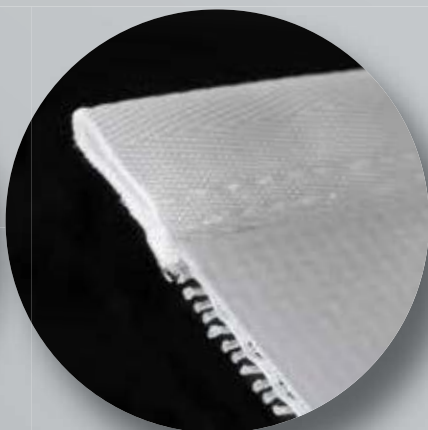





## The industry reference fabric choice

### SEFAR® TETEX DLW

- Best particle retention
- Best cake release
- Reduced installation and maintenance time



## Sefar unique marking technology

- Excellent identification and traceability
- No contamination
- No fading
- No shedding

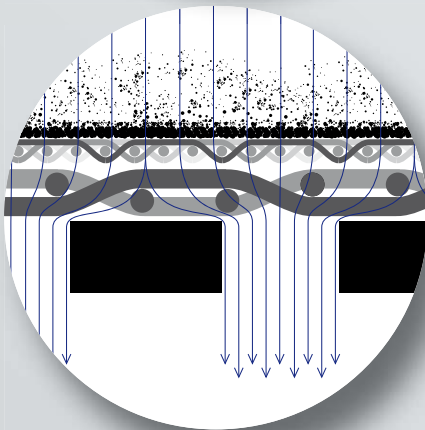

## DLW integrated drainage layer

Improved production capacity



EC 1935/2004	✓
EC 10/2011	✓
GMP EC 2023/2006 or cGMP	✓
FDA CFR 177	✓
ISO 9001	✓
Single packaging	✓
Customized marking	✓
Traceability	✓

	Material	Air permeability [cfm]	Air permeability [l/(m <sup>2</sup> · s)]	Air permeability [l/(dm <sup>2</sup> · min)]	Nominal pore size [µm]	Weight [g/m <sup>2</sup> ]
05-8000-SK 007 PHARMA	PP	3,8	30	18	7	420
05-8000-SK 008 PHARMA	PP	5	40	24	8	420
05-8000-SK 012 PHARMA	PP	6,3	50	30	12	455
05-8000-K 020 PHARMA	PP	12,5	100	60	20	425
05-8000-SK 030 PHARMA	PP	25	200	120	30	440
05-8000-K 050 PHARMA	PP	50	400	240	50	440
05-8000-K 085 PHARMA	PP	75	600	360	85	440
05-8000-W 120 PHARMA	PP	212,5	1700	1020	120	425
17-8000-SK 008 PHARMA	PEEK	5,6	45	27	8	586
17-8000-SK 020 PHARMA	PEEK	12,5	100	60	20	586
17-8000-K 040 PHARMA	PEEK	37,5	300	180	40	586
17-8000-SK 085 PHARMA	PEEK	100	800	480	85	512

# Filter Nutches and Horizontal Filter Discs

## Sefar unique PEEK polymer fabrics

- Resistance to high temperature
- High chemical resistance



## The industry reference fabric choice

### SEFAR® TETEX DLW

- Best particle retention
- Best cake release
- Reduced installation and maintenance time

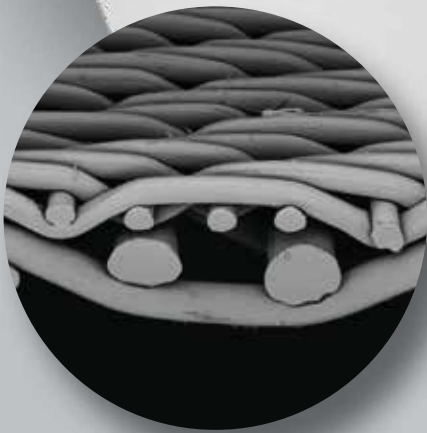

### SEFAR TETEX® MULTI

- Maximal particle retention
- Good strength
- Flexibility



### SEFAR TETEX® MONO

- Maximal particle retention with maximal permeability
- Optimal cleaning properties

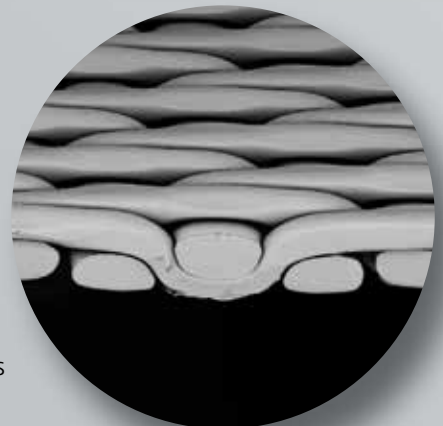

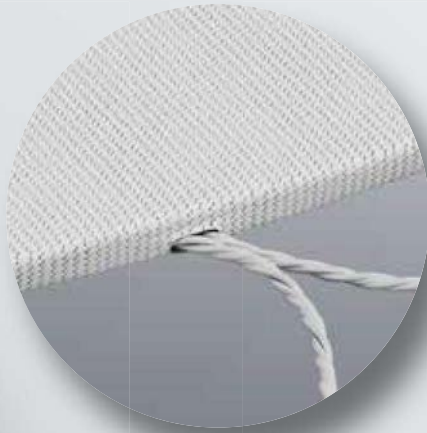

### All options available for easy installation

- Hemmed
- Taped
- Cord
- Laser cut



### Sefar unique marking technology

- Excellent identification and traceability
- No contamination
- No fading
- No shedding

EC 1935/2004	✓
EC 10/2011	✓
GMP EC 2023/2006 or cGMP	✓
FDA CFR 177	✓
ISO 9001	✓
Single packaging	✓
Customized marking	✓
Traceability	✓



	Material	Air permeability [cfm]	Air permeability [l/(m <sup>2</sup> · s)]	Air permeability [l/(dm <sup>2</sup> · min)]	Nominal pore size [µm]	Weight [g/m <sup>2</sup> ]
Double layer fabric						
<b>05-8000-SK 007 PHARMA</b>	PP	3,8	30	18	7	420
<b>05-8000-SK 008 PHARMA</b>	PP	5,0	40	24	8	420
<b>05-8000-SK 012 PHARMA</b>	PP	6,3	50	30	12	455
<b>05-8000-K 020 PHARMA</b>	PP	12,5	100	60	20	425
<b>05-8000-SK 030 PHARMA</b>	PP	25,0	200	120	30	440
<b>05-8000-K 050 PHARMA</b>	PP	50,0	400	240	50	440
<b>05-8000-K 085 PHARMA</b>	PP	75,0	600	360	85	440
<b>05-8000-W 120 PHARMA</b>	PP	212,5	1700	1020	120	425
<b>17-8000-SK 008 PHARMA</b>	PEEK	5,6	45	27	8	586
<b>17-8000-SK 020 PHARMA</b>	PEEK	12,5	100	60	20	586
<b>17-8000-K 040 PHARMA</b>	PEEK	37,5	300	180	40	586
<b>17-8000-SK 085 PHARMA</b>	PEEK	100,0	800	480	85	512
Multifilament fabric						
<b>05-4-660 K PHARMA</b>	PP	0,5	4	2,4	–	660
<b>05-11-360 SK PHARMA</b>	PP	1,4	11	6,6	–	360
<b>17-10-240 K PHARMA</b>	PEEK	1,3	10	6	–	235
<b>17-25-240 W PHARMA</b>	PEEK	3,1	25	15	–	235
Monofilament fabric						
<b>05-1100-SK 014 PHARMA</b>	PP	12,5	100	60	14	136
<b>05-1050-SK 025 PHARMA</b>	PP	11,9	95	57	25	210
<b>05-1550-K 053 PHARMA</b>	PP	21,3	170	102	53	300

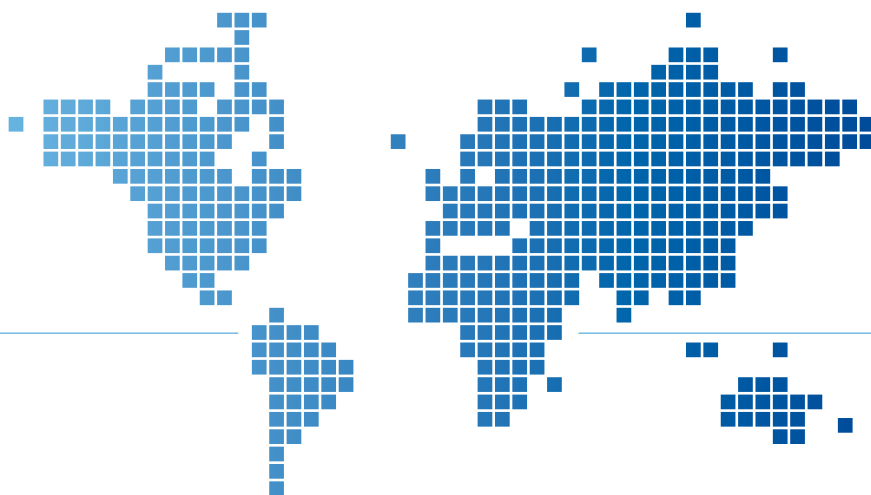

## Sefar worldwide

Sefar is the leading manufacturer of precision fabrics from monofilaments for the screen printing and filtration market. Sefar products are used in a wide variety of industries, reaching from electronics, graphics, medical, automotive, food and pharmaceutical applications to aerospace, mining & refining and architecture. With its profound understanding of the applications, Sefar helps its customers to achieve optimum results in their industrial processes. Subsidiaries and fabrications centers around the world provide local technical service for the broad range of solutions offered by Sefar.

### Headquarters

**Sefar AG**  
Hinterbissastrasse 12  
9410 Heiden – Switzerland  
Phone +41 71 898 57 00  
Fax +41 71 898 57 21  
filtration@sefar.com  
[www.sefar.com](http://www.sefar.com)

### Subsidiaries Africa

**South Africa** – Kya Sand  
Phone +27 11 708-2485  
info@sefarfilterpure.com

**Morocco** – Casablanca  
Phone +212 522 66 14 66  
info@sefar.ma

### Subsidiaries Americas

**USA** – Buffalo  
Phone +1 800 995 0531  
sales@sefar.us

**Canada** – Saguenay  
Phone +1 418 690 0888  
info.bd@sefar.com

**Brazil** – São Bernardo do Campo  
Phone +55 11 4390 6300  
contato.brasil@sefar.com

**Mexico** – Cuautitlan Izcalli  
Phone +52 55 2291 0652  
info.mexico@sefar.com

### Subsidiaries Australia & New Zealand

**Australia** – Huntingwood  
Phone +61 2 8822 1700  
oceania@sefar.com

**New Zealand** – MT Wellington  
Phone +64 9 527 4409  
salesnz@sefar.com

### Subsidiaries Asia

**China** – Suzhou  
Phone +86 512 6283 6383  
info.cn@sefar.com

**India** – District Thane  
Phone +91 2522 2940-34 /35 /36  
info.in@sefar.com

**Korea** – Seoul  
Phone +82 2 713 9134  
info.kr@sefar.com

**Malaysia** – Johor  
Phone +60 7 861 0023  
info.my@sefar.com

**Singapore**  
Phone +65 6299 9092  
info.sg@sefar.com

**Thailand** – Bangkok  
Phone +662 6670-024  
info.th@sefar.com

**Vietnam** – Ho Chi Minh City  
Phone +84 862 925 562/3  
info.vn@sefar.com

### Subsidiaries Europe

**England** – Bury  
Phone +44 161 765 3530  
sales@sefar.co.uk

**France** – Lyon  
Phone +33 472 13 14 15  
vente@sefar.com

**Germany** – Edling  
Phone +49 8071 90400 0  
info@sefar.de

**Italy** – Collegno  
Phone +39 011 42 001  
info@sefar.it

**Netherlands** – Lochem  
Phone +31 573 25 82 50  
info@sefar.nl

**Poland** – Poznan  
Phone +48 511 467 467  
biuro.pl@sefar.com

**Spain** – Cardedeu  
Phone +34 93 844 47 10  
info.maissa@sefar.com

**Turkey** – Ankara  
Phone +90 312 287 34 14  
info.tr@sefar.com

Our current general sales conditions shall apply.  
Please consult the current local product data sheet prior to any use.

