

Die Welt der Spannzangen

The World of Collets



Online-Shop
mit aktuellem
Artikelbestand



Online Shop
with Current
Stock
Quantities



REVOTEC®
Online Shop

Prüfen Sie einfach und schnell Preise und Verfügbarkeit und bestellen Sie unter <https://revotec-shop.de>
For a simple and fast check of prices and availability and ordering, go to our website <https://revotec-shop.de>

Schritt/Step

1

Selektieren Sie die gesuchte Spannzange nach Kategorie, dann nach Typ und zuletzt nach Profil.

Select the required collet by category, then by type and finally by profile.



Oder geben Sie den Spannzangentyp (z.B. 386E oder K32) ein und klicken Sie auf SUCHE.

Or enter the collet type (f.e 386E or K32) into the search field and click on SEARCH.

Schritt/Step

2

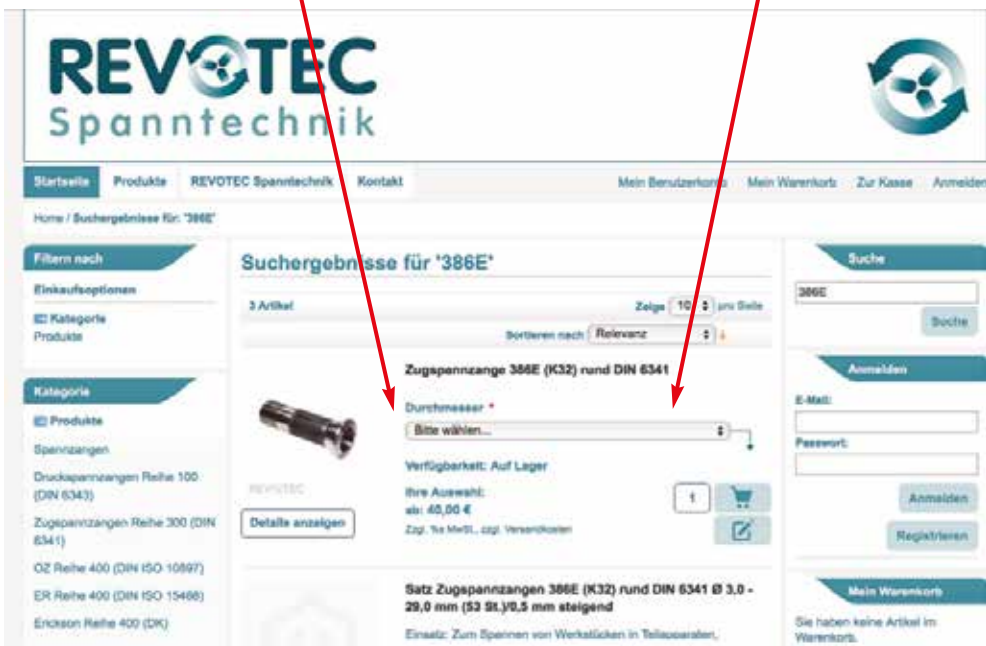

Wählen Sie den Durchmesser und der Preis und die Lagermenge werden angezeigt.
Pick the required diameter and the price and stock quantity will be displayed.

Ausschleifservice im Haus (Sondermaße)
In-House Grinding Service (Special Diameters)

Umfangreiche
Lagerhaltung
*Extensive Stock
Holding*

Spannzangen
für den Handel, OEM
und gewerbliche
Abnehmer
*Collets
for Distributors, OEM
and Business
Customers*

Günstige Preise
zur Stärkung Ihrer
Wettbewerbsfähigkeit
*Favourable prices to
raise your competitiveness*



Online-Shop mit aktuellem Artikelbestand
Online-Shop with Current Stock Quantities

- Lieferung neutraler Produkte in neutraler Verpackung
 - Streckengeschäft >
Direkte Lieferung im Kundenauftrag
 - Ausschleifen von Spannzangen auf Sondermaß (im Haus)
 - Volumenabhängige Leistungen/Artikel:
 - Private Label
 - Spannzangen mit Sonderprofil
 - Rahmenvereinbarungen mit Lagerbevorratung (Abruf)
 - Spannzangen in Zollmaßen auf Anfrage lieferbar
- *Delivery of neutral collets in neutral packaging*
 - *Drop-Shipping >*
Goods are delivered directly to your customer
 - *Grinding of special diameters (In-House)*
 - *Volume-Based Services/Items:*
 - *Private label*
 - *Collets with special profile*
 - *Framework agreement incl. stock inventory (on demand)*
 - *Collets in imperial sizes are available on request*



Inhaltsverzeichnis	Table of Content	Seite Page
Werkstückspannung	Workpiece Clamping	5-24
> Druckspannzangen DIN 6343 (Reihe 100) Rund, Sechs- und Vierkant	<i>Dead-length Collets Round DIN 6343 (Series 100)</i> <i>Round, Hexagon and Square</i>	5-9
> Notfall-Druckspannzangen	<i>Emergency Dead-Length Collets</i>	9
> Vorbau-Druckspannzangen	<i>Extended Nose Dead-Length Collets</i>	10
> Mehrbereichs-Spannzangen (Rubberflex©)	<i>Multirange Collets (Rubberflex©)</i>	10
> Führungsbuchsen und Spannhülsen	<i>Guide Bushes and Bar Feed Collets</i>	11-13
> Spannköpfe für Ein- und Mehrspindel-Drehautomaten	<i>Clamping Heads for Single and Multi-Spindle Automatics</i>	14-15
> Spannzangen für Mehrspindel-Drehautomaten	<i>Collets for Multi-Spindle Automatics</i>	16-18
> Vorschubzangen (Reihe 200)	<i>Feed Fingers (Series 200)</i>	19
> Zugspannzangen DIN 6341 (Reihe 300) Rund, Sechs- und Vierkant	<i>Draw-in Collets DIN 6341 (Series 300)</i> <i>Round, Hexagon and Square</i>	20-22
> Vorbau, Hydromat- und Notfallzugspannzangen	<i>Extended Nose, Hydromat and Emergency Draw-In Collets</i>	23-24
Werkzeugspannung (Reihe 400/600)	Tool Clamping (Series 400/600)	25-34
> OZ-Spannzangen DIN ISO 10897 A und B Form A und B, Sätze	<i>OZ Collets DIN ISO 10897 A and B</i> <i>Form A and B, Sets</i>	25-27
> ER-Spannzangen DIN ISO 15488 B Standard, HP, UP, 2μ, übergroß (> DIN), Sätze	<i>ER Collets DIN ISO 15488 B</i> <i>Standard, HP, UP, 2μ, oversize (> DIN), Sets</i>	28-30
> Abgedichtete ER-Spannzangen / mit Spritzdüsen	<i>Sealed ER Collets / with Jet Holes</i>	31
> ER-Gewindebohrzangen ähnl. DIN ISO 15488 A	<i>ER Tap Collets sim. to DIN ISO 15488 A</i>	32
> Erickson-Spannzangen und -halter DK- und DF-Spannzangen, Spannzangenhalter	<i>Erickson Collets and Holders</i> <i>DA and TG Collets, Extension Holders</i>	33
> Spannzangen für Mehrspindel-Bohrköpfe (Reihe 600)	<i>Collets for Multispindle Drill Heads (Series 600)</i>	34
Impressum	Legal Notice / Disclaimer	35
> © 2018 Andreas Hauck Industrietechnik REVOTEC Spanntechnik ist eine eingetragene Marke der Andreas Hauck Industrietechnik	© 2018 Andreas Hauck Industrietechnik REVOTEC Spanntechnik is a registered trademark of Andreas Hauck Industrietechnik.	

Druckspannzangen DIN 6343 (Reihe 100)

Zum Spannen von Werkstücken
(Futter- oder Stangenbearbeitung)
in Drehmaschinen (konventionell oder CNCgesteuert)
in der Spindel oder im Spannzangenfutter.

Dead-Length Collets DIN 6343 (Series 100)

For spindle clamping of workpieces
(chucking or bar work)
in conventional or CNC lathes or clamping inside
a collet chuck.

Rundlaufgenauigkeit nach DIN 6343

Ø d	l	Rundlauf Standard	erhöhter Rundlauf
		Run-out Standard	Run-out High Acc.
mm	mm	mm	mm
1,0 - 1,6	6	0,02	0,015
1,6 - 3,0	10		
3,0 - 6,0	16		
6,0 - 10,0	25		
10,0 - 18,0	40	0,03	0,020
18,0 - 24,0	50		
24,0 - 30,0	60	0,04	0,030
30,0 - 50,0	80		
> 50,0	100		

Run-Out Accuracy acc. to DIN 6343

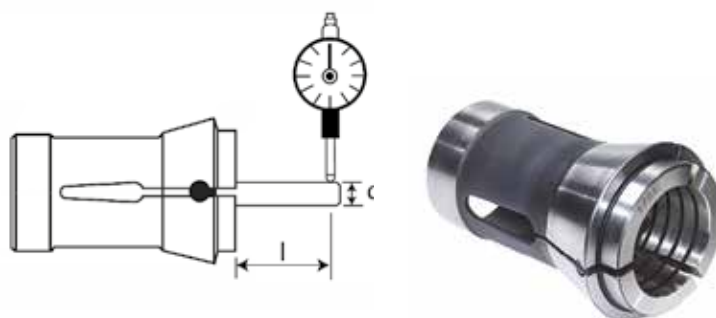

Technische Daten

Technical Data

Typ	Spannbereich	Steigung	d	D	L	α
Type	Clamp. Range	Increment	mm	mm	mm	
100E	1,0 - 4,5	0,5	6,0	10,0	30,0	15°
101E	1,0 - 6,0	0,5	8,0	12,0	42,0	16°
109E	1,0 - 7,0	0,5	10,0	15,5	47,5	20°
110E	1,0 - 7,0	0,5	10,0	16,0	43,0	15°
111E	1,0 - 7,0	0,5	10,0	16,0	46,0	20°
1155E	1,0 - 10,0	0,5	12,0	18,1	44,5	15°
116E	1,0 - 10,0	0,5	13,0	19,0	63,5	16°
117E	1,0 - 10,0	0,5	14,0	18,0	46,0	13°
120E	1,0 - 12,0	0,5	15,0	21,0	64,0	16°
1212E	1,0 - 13,0	0,5	16,0	21,0	64,0	16°
125E	1,0 - 14,0	0,5	17,5	22,0	51,0	15°
136E	1,0 - 16,0	0,5	20,0	26,0	54,0	15°
138E	1,0 - 16,0	0,5	20,0	28,0	67,0	16°
140E	1,0 - 16,0	0,5	22,0	33,0	55,0	15°
143E	1,0 - 20,0	0,5	25,0	31,0	54,0	15°
145E	1,0 - 20,0	0,5	25,0	35,0	77,0	16°
147E	1,0 - 24,0	0,5	27,0	38,0	72,7	15°
148E	1,0 - 24,0	0,5	28,0	38,0	70,0	15°
1446E	1,0 - 26,0	0,5	30,0	38,0	65,0	15°
157E	2,0 - 25,0	0,5	30,0	42,0	80,0	16°
161E	1,0 - 26,0	0,5	32,0	45,0	75,0	15°
162E	2,0 - 25,0	0,5	35,0	43,0	70,0	15°
163E	1,0 - 30,0	0,5	35,0	48,0	80,0	15°
1536E	1,0 - 32,0	0,5	37,0	47,0	92,0	16°
164E	1,0 - 32,0	0,5	38,1	49,2	108,0	15°
171E	1,0 - 37,0	0,5	42,0	55,0	94,0	15°
173E	1,0 - 42,0	0,5	48,0	60,0	94,0	15°
177E	6,0 - 52,0	1,0	58,0	70,0	94,0	15°
185E	2,0 - 60,0	1,0	66,0	84,0	110,0	15°
190E	60,0 - 80,0	1,0	88,0	106,0	115,0	15°
193E	20,0 - 80,0	1,0	90,0	107,0	130,0	15°

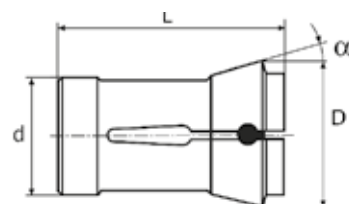

Alle nicht gelisteten
Druckspannzangentypen
sind auf Anfrage lieferbar.
Zwischenabmessungen
auf Anfrage (Ausschleif-
service im Haus).

Not listed types of
dead-length collets
are available upon
request.
Intermediate sizes
upon request
(in-house grinding
service).



Druckspannzangen Rund DIN 6343

Dead-Length Collets Round DIN 6343

Typ Type	Bezeichnung Description	Innenprofil Ins. Shape	Spannbereich Clamp. Range	Steigung* Increment*	Verfügbar. Availability	Preisgruppe/Price Group	
						Artikelnr. Part Number	Preis/St. Price/pc.
						A001.	PG 100
						mm	€
100E	F6 76-599	○	1,0	0,5	■	0100.0010	32,00
			1,5 - 2,5			0100.0015 - .0025	30,00
			3,0 - 4,5			0100.0030 - .0045	23,00
101E	F8 76-577	○	1,0	0,5	■	0101.0010	32,00
			1,5 - 2,5			0101.0015 - .0025	30,00
			3,0 - 6,0			0101.0030 - .0060	23,00
109E	F10 76-86	○	1,0	0,5	□	0109.0010	39,50
			1,5 - 2,5			0109.0015 - .0025	36,50
			3,0 - 7,0			0109.0030 - .0070	25,50
110E	F10 76-720	○	1,0	0,5	■	0110.0010	36,00
			1,5 - 2,5			0110.0015 - .0025	34,00
			3,0 - 7,0			0110.0030 - .0070	28,00
111E	F10 76-1178	○	1,0	0,5	■	0111.0010	36,00
			1,5 - 2,5			0111.0015 - .0025	34,00
			3,0 - 7,0			0111.0030 - .0070	28,00
1155E	F12 76-78	○	1,0	0,5	■	1155.0010	36,75
			1,5 - 2,5			1155.0015 - .0025	35,00
			3,0 - 10,0			1155.0030 - .0100	29,50
116E	F13 76-357	○	1,0	0,5	■	0116.0010	36,50
			1,5 - 2,5			0116.0015 - .0025	35,00
			3,0 - 10,0			0116.0030 - .0100	23,00
117E	F14 76-98	○	1,0	0,5	■	0117.0010	34,00
			1,5 - 2,5			0117.0015 - .0025	30,75
			3,0 - 10,0			0117.0030 - .0100	23,50
120E	F15 76-580	○	1,0	0,5	■	0120.0010	29,00
			1,5 - 2,5			0120.0015 - .0025	27,50
			3,0 - 12,0			0120.0030 - .0120	20,50
1212E	F16 76-1076	○	1,0	0,5	■	1212.0010	34,00
			1,5 - 2,5			1212.0015 - .0025	32,00
			3,0 - 13,0			1212.0030 - .0130	25,75
125E	F17,46 76-79	○	1,0	0,5	■	0125.0010	38,75
			1,5 - 2,5			0125.0015 - .0025	36,00
			3,0 - 14,0			0125.0030 - .0140	28,75
136E	F20 76-201	○	1,0	0,5	■	0136.0010	36,00
			1,5 - 2,5			0136.0015 - .0025	33,00
			3,0 - 16,0			0136.0030 - .0160	26,00
138E	F20 76-87	○	1,0	0,5	■	0138.0010	36,00
			1,5 - 2,5			0138.0015 - .0025	33,00
			3,0 - 16,0			0138.0030 - .0160	26,00
140E	F22 76-71	○	1,0	0,5	■	0140.0010	34,75
			1,5 - 2,5			0140.0015 - .0025	31,75
			3,0 - 16,0			0140.0030 - .0160	24,00
143E	F25 76-581	○	1,0	0,5	□	0143.0010	46,75
			1,5 - 2,5			0143.0015 - .0025	43,75
			3,0 - 20,0			0143.0030 - .0200	38,00
145E	F25 76-64	○	1,0	0,5	■	0145.0010	35,75
			1,5 - 2,5			0145.0015 - .0025	33,50
			3,0 - 20,0			0145.0030 - .0200	26,75



Ausführung Bohrung:
Design of Bore Hole:



Glatte Bohrung ≤ 8,0 mm
Smooth Bore ≤ 8,0 mm



Querrillen > 8,0 mm
Horiz. Grooves > 8,0 mm

Alle nicht gelisteten Druckspannzagentypen sind auf Anfrage lieferbar.
* Zwischenabmessungen auf Anfrage (Ausschleifservice im Haus).

Not listed types of dead-length collets are available upon request.

* Intermediate sizes upon request (inhouse grinding service).

Fortsetzung auf Seite 7 / continued on page 7

Bestellbeispiel: Druckspannzange 145 E Ø 11,0 mm
▷ Artikel nr. **A001.0145.0110**

Ordering Example: Dead-Length Collet 145 E Ø 11,0 mm
▷ Part No. **A001.0145.0110**

Druckspannzangen Rund DIN 6343

Dead-Length Collets Round DIN 6343

Fortsetzung von Seite 6 / continued from page 6

Typ	Bezeichnung	Innenprofil	Spannbereich	Steigung*	Verfügbark.	Preisgruppe/Price Group	PG 100
						Artikelnr.	Preis/St.
Type	Description	Ins. Shape	Clamp. Range	Increment*	Availability	Part Number	Price/pc.
			mm	mm		A001.	€
147E	F27 76-22	○	1,0	0,5	☐	0147.0010	46,50
			1,5 - 2,5			0147.0015 - .0025	42,50
			3,0 - 24,0			0147.0030 - .0240	37,00
148E	F28 76-93	○	1,0	0,5	■	0148.0010	35,00
			1,5 - 2,5			0148.0015 - .0025	32,50
			3,0 - 24,0			0148.0030 - .0240	27,50
1446E	F30 76-101	○	1,0	0,5	■	1446.0010	52,00
			1,5 - 2,5			1446.0015 - .0025	47,50
			3,0 - 26,0			1446.0030 - .0260	37,50
157E	F30 76-63	○	2,0 - 2,5	0,5	■	0157.0020 - .0025	59,00
			3,0 - 25,0			0157.0030 - .0250	47,50
161E	F32 76-221	○	1,0 - 1,5	0,5	■	0161.0010 - .0015	35,00
			2,0 - 2,5			0161.0020 - .0025	31,25
			3,0 - 26,0			0161.0030 - .0260	27,25
162E	F35 76-67	○	2,0 - 2,5	0,5	■	0162.0020 - .0025	50,00
			3,0 - 25,0			0162.0030 - .0250	35,00
163E	F35 76-94	○	1,0 - 1,5	0,5	■	0163.0010 - .0015	42,50
			2,0 - 2,5			0163.0020 - .0025	39,00
			3,0 - 30,0			0163.0030 - .0300	32,50
1536E	F37 76-740	○	1,0 - 1,5	0,5	■	1536.0010 - .0015	57,50
			2,0 - 2,5			1536.0020 - .0025	56,00
			3,0 - 32,0			1536.0030 - .0320	43,00
164E	F38 76-72	○	1,0 - 1,5	0,5	■	0164.0010 - .0015	63,50
			2,0 - 2,5			0164.0020 - .0025	61,50
			3,0 - 32,0			0164.0030 - .0320	46,50
171E	F42 76-99	○	1,0 - 1,5	0,5	■	0171.0010 - .0015	63,50
			2,0 - 2,5			0171.0020 - .0025	60,00
			3,0 - 37,0			0171.0030 - .0370	47,00
173E	F48 76-81	○	1,0 - 1,5	0,5	■	0173.0010 - .0015	60,00
			2,0 - 2,5			0173.0020 - .0025	52,50
			3,0 - 42,0			0173.0030 - .0420	45,50
177E	F58 17-355	○	< 10,0	1,0	☐	0177.00xx - .0090	a.A./POA
			10,0 - 52,0			0177.0100 - .0520	95,00
185E	F66 76-359	○	2,0	1,0	■	0185.0020	110,00
			3,0			0185.0030	103,00
			4,0 - 60,0			0185.0040 - .0600	86,50
190E	F88	○	< 60,0	1,0	☐	0190.00xx - .0590	a.A./POA
			60,0 - 80,0			0190.0600 - .0800	261,00
193E	F90	○	< 20,0	1,0	☐	0193.00xx - .0190	a.A./POA
			20,0 - 80,0			0193.0200 - .0800	261,00



Alle nicht gelisteten Druckspannzangentypen sind auf Anfrage lieferbar. Zwischenabmessungen auf Anfrage (Ausschleifservice im Haus).

Not listed types of dead-length collets are available upon request. Intermediate sizes upon request (in-house grinding service).

Bestellbeispiel:
Druckspannzange 161E rund Ø 10,0 mm
▷ Artikelnr. **A001.0161.0100**

Ordering Example:
Dead-Length Collet 161E round Ø 10,0 mm
▷ Item No. **A001.0161.0100**

Sechs- und Vierkant-Druckspannzangen DIN 6343

Hex and Square Dead-Length Collets DIN 6343

Typ Type	Bezeichnung Description	Innenprofil Ins. Shape	Spannbereich (SW) Clamping Range (WAF) mm	Verfügbark. Availability	Preisgruppe/Price Group	
					Artikelnr. Part Number A001.	Preis/St. Price/pc. €
120E	F15 76-580		4 - 9	■	0120.1040 - .1090	36,00
			4 - 7	■	0120.2040 - .2070	36,00
1212E	F16 76-1076		4 - 10	■	1212.1040 - .1100	49,00
			4 - 8	□	1212.2040 - .2080	49,00
136E	F20 76-201		3 - 14	■	0136.1030 - .1140	42,00
			3 - 10	■	0136.2030 - .2100	42,00
138E	F20 76-87		4 - 6	■	0138.1040 - .1060	44,00
			7 - 14	■	0138.1070 - .1140	41,00
			4 - 6	□	0138.2040 - .1060	44,00
140E	F22 76-71		7 - 11	□	0138.2070 - .2110	41,00
			4 - 6	■	0140.1040 - .1060	42,50
			7 - 14	■	0140.1070 - .1140	39,50
140E	F22 76-71		4 - 6	■	0140.2040 - .2060	42,50
			7 - 11	■	0140.2070 - .2140	39,50
			4 - 6	■	0145.1040 - .1060	46,00
145E	F25 76-64		7 - 17	■	0145.1070 - .1170	42,50
			4 - 6	■	0145.2040 - .2060	46,00
			7 - 14	■	0145.2070 - .2140	42,50
148E	F28 76-93		4 - 6	■	0148.1040 - .1060	43,50
			7 - 17•19•20	■	0148.1070 - .1200	40,50
			4 - 6	■	0148.2040 - .2060	43,50
1446E	F30 76-101		7 - 16	■	0148.2070 - .2160	40,50
			4 - 6	□	1446.1040 - .1060	67,00
			7 - 17•19•20•22	□	1446.1070 - .1220	63,00
161E	F32 76-221		4 - 6	□	1446.2040 - .2060	67,00
			7 - 18	□	1446.2070 - .2180	63,00
			4 - 6	■	0161.1040 - .1060	47,00
161E	F32 76-221		7 - 17•19•22	■	0161.1070 - .1220	43,00
			5 - 6	■	0161.2040 - .2060	47,00
			7 - 16•18	■	0161.2070 - .2180	43,00
163E	F35 76-94		4 - 6	■	0163.1040 - .1060	53,50
			7 - 17•19•21•22•24•27	■	0163.1060 - .1270	49,00
			5 - 6	■	0163.2040 - .2060	53,50
1536E	F37 76-740		7 - 16•18•20•21	■	0163.2070 - .2210	49,00
			4 - 6	□	1536.1040 - .1060	67,00
			7 - 17•19•21•22•24•27	□	1536.1070 - .1270	64,00
164E	F38 76-72		4 - 6	□	1536.2040 - .2060	67,00
			7 - 23	□	1536.2070 - .2230	64,00
			4 - 6	■	0164.1040 - .1060	75,00
171E	F42 76-99		7 - 17•19•21•22•24•27	■	0164.1070 - .1270	69,00
			4 - 6	□	0164.2040 - .2060	75,00
			7 - 23	□	0164.2070 - .2230	69,00
171E	F42 76-99		4 - 6	■	0171.1040 - .1060	74,00
			7 - 19•22•24•27•30•31	■	0171.1070 - .1310	70,00
			4 - 6	■	0171.2040 - .2060	74,00
			7 - 16•18•19•20•22•24•25	■	0171.2070 - .2250	70,00



Ausführung Bohrung
Design of Bore Hole



Glatte Bohrung ≤ 12,0 mm
Smooth Bore ≤ 12,0 mm



Querrillen > 12,0 mm
Horiz. Grooves > 12,0 mm

Andere Schlüsselweiten
auf Anfrage lieferbar!

Different sizes available
on request!

Fortsetzung auf Seite 9 / continued on page 9

Bestellbeispiel:
Vierkant-Druckspannzange
148E SW 10,0 mm
▷ Artikelnr. **A001.0148.2100**

Ordering Example:
Dead Length Square Collet
148E WAF 10 mm
▷ Part No. **A001.0148.2100**

Sechs- und Vierkant-Druckspannzangen DIN 6343

Hex and Square Dead-Length Collets DIN 6343

Fortsetzung von Seite 8 / continued from page 8

Typ	Bezeichnung	Innenprofil	Spannbereich (SW)	Verfügbark.	Preisgruppe/Price Group	
					Artikelnr.	Preis/St.
Type	Description	Ins. Shape	Clamping Range (WAF)	Availability	Part Number	Price/pc.
			mm		A001.	€
173E	F48 76-81		4 - 5,5	■	0173.1040 - .1055	68,00
			6 - 27		0173.1060 - .1270	65,00
			28•30•32•36		0173.1280 - .1360	68,00
177E	F58 17-355		4 - 5	■	0173.2040 - .2050	68,00
			6 - 18		0173.2060 - .2180	64,00
			19 - 22 • 24 - 28 • 30		0173.2190 - .2300	68,00
185E	F66 76-359		8 - 17•19•21•22•24•27	■	0177.1080 - .1270	120,00
			28•30•32•35•36•38 - 42•45		0177.1280 - .1440	130,00
			•46•48•50		0177.2080 - .2270	120,00
190E	F88		8 - 27	□	0177.2300 - .2360	130,00
			28 - 44		0190.10xx - .1690	375,00
			30 - 36		0190.20xx - .2570	375,00
193E	F90		nach Kundenvorgabe/ acc. to customer specifications	□	0193.10xx - .1680	385,00
			nach Kundenvorgabe/ acc. to customer specifications		0193.20xx - .2560	385,00
			nach Kundenvorgabe/ acc. to customer specifications			



Ausführung Bohrung:
Design of Bore Hole:



Glatte Bohrung ≤ 12,0 mm Querrillen > 12,0 mm
Smooth Bore ≤ 12,0 mm Horiz. Grooves > 12,0 mm

Bestellbeispiel:
Sechskant-Druckspannzange
185E SW 36 mm
▷ Artikelnr. **A001.0185.1360** ▷

Ordering Example:
Hex Dead-length Collet
185E WAF 36 mm
▷ Part No. **A001.0185.1360**

Andere Schlüsselweiten
auf Anfrage lieferbar!
Different sizes available
on request!

Notfalldruckspannzangen Rund Reihe 100

Zur Selbsthilfe bei speziellen Durchmesser oder Formen,
wenn Standardspannzangen nicht geeignet sind.
Schaft gehärtet, Kopf weich (ca. 45 HRC). Mit 3 Stiften
in den Schlitzen. Nur für kurzzeitigen Einsatz geeignet.

Emergency Dead-Length Collets Round Series 100

For self-help, if an unusual diameter or shape is needed
and standard collets cannot be used. Hardened
shank and soft face (ca. 45 HRC). 3 pins in the face.
For temporary use only.

Typ	Bezeichnung	Innenprofil	Vorbereitung	Verfügbark.	Preisgruppe/Price Group	
					Artikelnr.	Preis/St.
Type	Description	Ins. Shape	Pilot Hole	Availability	Part Number	Price/pc.
			Ø in mm		A001.	€
140E	F22		3,0	■	0140.9000	46,25
145E	F25		3,0	□	0145.9000	a.A./POA
148E	F28		3,0	■	0148.9000	48,75
1446E	F30		3,0	□	1446.9000	a.A./POA
161E	F32		3,0	■	0161.9000	54,00
163E	F35		3,0	■	0163.9000	65,00
171E	F42		3,0	□	0171.9000	a.A./POA
173E	F48		3,0	■	0173.9000	82,50
177E	F58		3,0	□	0177.9000	a.A./POA
185E	F66		4,0	■	0185.9000	142,50



Detail

Bestellbeispiel:
Notfallspannzange 173E
▷ Artikelnr. **A001.0173.9000**

Ordering Example:
Emergency Collet 173E
▷ Part No. **A001.0173.9000**

Vorbau-Druckspannzangen

Vorbau-Spannzangen Reihe 100 mit Kegel zum Einsatz auf der Abgreifspindel oder zum Ausgleich möglicher Werkzeuginterferenzen.

Extended Nose Dead Length Collets

Dead length collets Series 100 with tapered extended nose for doing pick-off work or for compensating tooling interferences.

Typ	Bezeichnung	Vorbaulänge			Spannbereich	Verfügbar.	Artikelnr.	Preisgruppe/Price Group		
		Ext. Nose Length						mm	A001.	PG 103
		I	Y	L						Preis/St.
Type	Description	mm			Availability	Part Number	Price/pc.	€		
116E	F13	12	6	70	1,0-10,0	<input type="checkbox"/>	0116.7010 - .7100	a.A./POA		
120E	F15	15	9	73	1,0-12,0	<input type="checkbox"/>	0120.7010 - .7120	a.A./POA		
1212E	F16	15	9	73	1,0-12,0	<input type="checkbox"/>	1212.7010 - .7130	a.A./POA		
136E	F20	15	10	64	1,0-16,0	<input type="checkbox"/>	0136.7010 - .7160	a.A./POA		
138E	F20 76-2027	20	13	80	1,0-16,0	<input type="checkbox"/>	0138.7010 - .7160	a.A./POA		
145E	F25	20	10	87	1,0-20,0	<input type="checkbox"/>	0145.7010 - .7200	a.A./POA		
1446E	F30 76-2019	20	14	79	1,0-26,0	<input type="checkbox"/>	1446.7010 - .7260	a.A./POA		
1536E	F37 76-2020	25	15	107	1,0-32,0	<input type="checkbox"/>	1536.7010 - .7320	a.A./POA		
171E	F42	28	19	113	1,0-32,0	<input type="checkbox"/>	0171.7010 - .7320	a.A./POA		
173E	F48 76-2006	28	19	113	2,0-42,0	<input type="checkbox"/>	0173.7020 - .7420	a.A./POA		

Bestellbeispiel:
Vorbau-Druckspannzange 1212E Ø 8,5 mm
▷ Artikelnr. **A001.1212.7080**

Ordering Example:
Extended Nose Dead-Length Collet 1212E Ø 8,5 mm
▷ Part No. **A001.1212.7080**

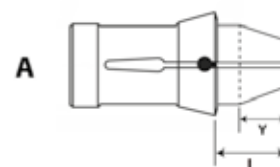

Artikelnr./Part No.: A001.xxxx.5xxx-Y-Z

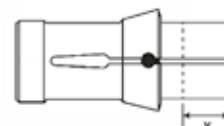

Auf Anfrage lieferbar: Vorbau-Druckspannzangen mit verlängertem runden Vorbau
Available on request: Dead-length collets with round extended nose

Mehrbereichs-Spannzangen (Rubber Flex ©)

Austauschbar mit Druckspannzangen DIN 6343. Für Stangen- oder Futterbearbeitung. Spannbereich ± 1 mm zum Nenndurchmesser (Außer 755E). Abgedichtet gegen Kühlschmierstoffe und Späne.

Multi-Range Collets (Rubber Flex ©)

Exchangeable with dead-length collets DIN 6343. For bar or chuck work. Clamping range ± 1 to nominal diameter (except 755E). Sealed against coolant and swarf.

Glatte Ausführung

Smooth Bore

Typ	Bezeichnung	Innenprofil	Spannbereich		Steigung	Verfügbar.	Artikelnr.	Preisgruppe/Price Group	
			Clamp. Range					A001.	PG 105
			mm						mm
Type	Description	Ins. Shape	mm		Increment	Availability	Part Number	Price/pc.	
755E	140E / RF12	○	3/4 - 15/16		1,0	<input type="checkbox"/>	0755.0304 - .1516	a.A./POA	
760E	148E / RF18	○	3/5 - 18/20		2,0	<input type="checkbox"/>	0760.0305 - .1820	a.A./POA	
765E	161E / RF20	○	4/6 - 24/26		2,0	<input type="checkbox"/>	0765.0406 - .2426	a.A./POA	
770E	163E / RF24	○	6/8 - 28/30		2,0	<input type="checkbox"/>	0770.0608 - .2830	a.A./POA	
775E	173E / RF36	○	7/9 - 41/43		2,0	<input type="checkbox"/>	0775.0608 - .4143	a.A./POA	
780E	185E / RF52	○	19/21 - 59/61		2,0	<input type="checkbox"/>	0780.1921 - .5961	a.A./POA	
			61/63				0780.6163	a.A./POA	
			63/65				0780.6365	a.A./POA	

Bestellbeispiel:
Mehrbereichsspannzange 770E Ø 24-26 mm
▷ Artikel-Nr. **A007.0770.2426**

Ordering Example:
Multi-range Collet 770E Ø 24-26 mm
▷ Part No. **A007.0770.2426**



Auf Anfrage lieferbar:
Mit Längs- und Querrillen (Full Grip) zur Bearbeitung von Stangenmaterial mit großen Spanntoleranzen (nur 775E und 780E).
Available on request in double-serrated design for bar work with wide clamping (only 775E and 780E)

Verstellbare Führungsbuchsen

Mit Hartmetalleinsatz für Langdrehautomaten

Adjustable Guide Bushes

With carbide insert for swiss automatic lathes

Führungsbuchsen

Vergleichstabelle / Comparison Chart					
Typ Type	Dünnere	Neukomm	Meister		US Code (Southwick & Meister)
				alt/old	
I351	J3	51.001	T9-44	1351	PD4
F3001	J4	3.001	T11-53-M10.075	1352A	TD7
I352		498.001	T11-53-M10.080	1352	
I353	J6R	8.001	T16-59	1353	TD10
F853	B212A	166.001	T18-59-M16.1	853	
SD125R	B212	171.001	T18-59-M18.1	855	SD125R
T221	B301	450.001	T21-57.4	221T	SNC15
I354	J7A	13.001	T22-68-M19.1	1354	TD20
F391	J7AR	39.001	T22-68-M22.1	39001T	TD20R
F605	B238	61.002	T24-61	605	0201
TD26		99.001	T26-77	TD26	TD26
T223	B261	22.001	T28-82-M25.1	223T	TD25S
T223S		22.010	T28-82-M27.1	223TS	
I357	B260	18.001	T28-81	1357	TD25
F355	B214	282.001	T32-71	355	TSD20
T227	B227	451.001	T34-87.5	227T	CD25
F854	B207A	172.001	T40-72-M36.1	854	
T229	J9	28.001	T42-82-C16	229T	TD32S
T245	B250	250.001	T45-82	245T	
T246	B246	467.001	T46-92	246T	TD38
T249	B240	496.001	T48-81-C10	249T	
T248		464.001	T48-82	248T	STM38

Guide Bushes

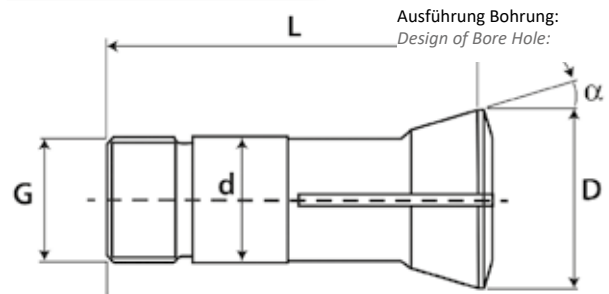

Führungsbuchsen rund

Guide Bushes round

Typ Type	Führungsb. Gruppe G. bush Group	d mm	D mm	L mm	α	Gewinde Thread G	Profil Ins. Shape	Spannbereich Clamp. Range mm	Steigung* Increment* mm	Verfügbar. Availability	Artikelnr. Part Number
I351	①	9	12,5	44	16°	M8 x 0,75	○	1,0 - 6,0	0,5	☐	A020.0351.00100 - .00600
F3001	①	11	14,5	53	16°	M10 x 0,75	○	1,0 - 7,0	0,5	☐	A020.3001.00100 - .00700
I352	①	11	14,5	53	16°	M10 x 0,8	○	1,0 - 7,0	0,5	☐	A020.0352.00100 - .00700
I353	①	16	20,5	59	16°	M14 x 1	○	1,0 - 10,0	0,5	■	A020.0353.00100 - .01000
F853	①	18	21,8	59	30°	M16 x 1	○	1,0 - 13,0	0,5	■	A020.0853.00100 - .01300
SD125R	①	18	21,8	59	30°	M18 x 1	○	3,0 - 13,0	0,5	☐	A020.0125.00300 - .01300
T221	②	21	24	57,4	12°	M18 x 1	○	1,0 - 15,0	0,5	☐	A022.0221.00100 - .01500
I354	②	22	29	68	16°	M19 x 1	○	2,0 - 15,0	0,5	☐	A022.0354.00200 - .01500
F391	②	22	29	68	16°	M22 x 1	○	2,0 - 17,0	0,5	■	A022.0391.00200 - .01700
F605	②	24	29,5	61	30°	M24 x 1	○	2,0 - 17,0	0,5	■	A022.0605.00200 - .01700
TD26	②	26	29	77	16°	M25 x 1	○	2,0 - 20,0	0,5	☐	A022.TD26.00200 - .02000
T223	②	28	34	82	16°	M25 x 1	○	1,0 - 21,0	0,5	■	A022.0223.00100 - .02100
T223S	②	28	34	82	16°	M27 x 1	○	22,0 - 23,0	1,0	☐	A022.0223.02200 - .02300
I357	②	28	38	81	30°	M25 x 1	○	3,0 - 20,0	0,5	■	A022.0357.00300 - .02000
F355	②	32	39,8	71	30°	M32 x 1	○	3,0 - 22,0	0,5	☐	A022.0355.00300 - .02200
T227	②	34	41	87,5	10°	M34 x 1	○	3,0 - 25,0	0,5	■	A022.0227.00300 - .02500
F854	③	40	47,8	72	30°	M36 x 1	○	3,0 - 26,0	0,5	☐	A023.0854.00300 - .02600
T229	③	42	49	82	16°	M40 x 1	○	3,0 - 32,0	1,0	■	A023.0229.00300 - .03200
T245	④	45	52	82	16°	M42 x 1	○	2,0 - 35,0	1,0	☐	A024.0245.00200 - .03500
T246	④	46	53	92	16°	M45 x 1	○	2,0 - 38,0	1,0	☐	A024.0246.00200 - .03800
T249	④	48	54	82	16°	M46 x 1	○	2,0 - 38,0	1,0	☐	A024.0249.00200 - .03800
T248	④	48	54	81	10°	M46 x 1	○	2,0 - 38,0	1,0	■	A024.0248.00200 - .03800

* Zwischenabmessungen auf Anfrage lieferbar!
* Intermediate sizes are available on request!

Alle nicht gelisteten Führungsbuchsen auf Anfrage lieferbar!
Not listed types of guide bushes are available upon request.

Führungsbuchsen mit verlängertem Hartmetalleinsatz auf Anfrage lieferbar.
Guide bushes with extended carbide lining are available upon request.



Bestellbeispiel:
Führungsbuchse T223 Ø 13,0 mm
▷ ArtikeInr. **A022.0223.0130**

Ordering Example:
Guide Bush T223 Ø 13,0 mm
▷ Part No. **A022.0223.0130**



Führungsbuchsen rund

Guide Bushes round

				Preisgruppe/Price Group		PG 140	
Führungsbuchsen Gruppe ①		Führungsbuchsen Gruppe ②		Führungsbuchsen Gruppe ③		Führungsbuchsen Gruppe ④	
Guide Bushes Group ①		Guide Bushes Group ②		Guide Bushes Group ③		Guide Bushes Group ④	
∅ *	Preis/St.	∅ *	Preis/St.	∅ *	Preis/St.	∅ *	Preis/St.
	Price/pc.		Price/pc.		Price/pc.		Price/pc.
mm	€	mm	€	mm	€	mm	€
1,0	87,50	1,0	102,60				
1,5-2,0	75,10	1,5-2,0	88,20				
2,5-3,0	75,10	2,5-3,0	72,20	3,0	126,20	3,0	a.A./POA
3,5-4,0	66,90	3,5-4,0	69,70	4,0	114,70	4,0	a.A./POA
4,5-5,0	68,80	4,5-5,0	74,10	5,0	106,80	5,0	a.A./POA
5,5-6,0	75,10	5,5-6,0	81,20	6,0	105,10	6,0	a.A./POA
6,5-7,0	80,90	6,5-7,0	84,60	7,0	105,10	7,0	a.A./POA
7,5-8,0	84,70	7,5-8,0	88,20	8,0	105,10	8,0	a.A./POA
8,5-9,0	87,50	8,5-9,0	91,60	9,0	105,10	9,0	a.A./POA
8,5-10,0	90,40	8,5-10,0	95,30	10,0	105,10	10,0	a.A./POA
10,5-11,0	93,00	10,5-11,0	98,70	11,0	106,80	11,0	a.A./POA
11,5-12,0	97,00	11,5-12,0	103,40	12,0	106,80	12,0	a.A./POA
12,5-13,0	102,80	12,5-13,0	111,60	13,0	112,70	13,0	a.A./POA
		13,5-14,0	113,90	14,0	116,30	14,0	a.A./POA
		14,5-15,0	120,30	15,0	122,10	15,0	a.A./POA
		15,5-16,0	129,50	16,0	130,60	16,0	a.A./POA
		16,5-17,0	131,90	17,0	135,50	17,0	a.A./POA
		17,5-18,0	139,30	18,0	141,30	18,0	a.A./POA
		18,5-19,0	141,90	19,0	145,40	19,0	a.A./POA
		19,5-20,0	144,60	20,0	148,50	20,0	a.A./POA
		20,5-21,0	153,40	21,0	155,20	21,0	a.A./POA
		21,5-22,0	158,40	22,0	162,10	22,0	a.A./POA
		22,5-23,0	163,90	23,0	169,40	23,0	a.A./POA
		23,5-24,0	169,50	24,0	171,00	24,0	a.A./POA
		24,5-25,0	171,30	25,0	173,30	25,0	a.A./POA
				26,0	175,40	26,0	a.A./POA
				27,0	185,40	27,0	a.A./POA
				28,0	196,60	28,0	a.A./POA
				29,0	202,80	29,0	a.A./POA
				30,0	208,40	30,0	a.A./POA
				31,0	215,70	31,0	a.A./POA
				32,0	222,30	32,0	a.A./POA
						33,0-38,0**	a.A./POA
		T223S	22,0-23,0	198,70			



Bestellbeispiel:
Führungsbuchse T223 ∅ 13,0 mm
▷ Artikelnr. **A022.0223.0130**

Ordering Example:
Guide Bush T223 ∅ 13.0 mm
▷ Part No. **A022.0223.0130**

Führungsbuchsen Sechs- und Vierkant

Hex and Square Guide Bushes

				Preisgruppe/Price Group		PG 140	
Typ	Bezeichnung	Innenprofil	Spannbereich (SW)	Verfügbar.	Artikelnr.	Preis/St.	
Type	Description	Ins. Shape	Clamping Range (WAF)	Availability	Part Number	Price/pc.	
			mm		A020. - A024.*	€	
Alle 6k/4k Führungsbuchsen a. A. lieferbar / All hex/square guide bushes available on request			nach Kundenvorgabe / acc. to customers specifications		0xxx.10xx - .1xxx	a.A./POA	
					0xxx.20xx - .2xxx	a.A./POA	



Spannhülsen für Lademagazine

Spannhülsen zum Einsatz in Lademagazinen FMB, LNS, lemca, Traub, Tornos.



Abb. 1 / Fig. 1



Abb. 2 / Fig. 2

Bar Feed Collets for Bar Loaders

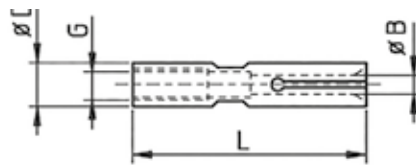
Bar feed collets for use in bar loaders FMB, LNS, lemca, Traub, Tornos.

Typ	Abb.	Ø D	Ø d	L	a	Innenprofil	Spannbereich S	Steigung	Verfügbark.	Preisgruppe/Price Group		
										Artikelnr.	Preis/St.	
Type	Fig.	mm	mm	mm	mm	Ins. Shape	Clamp. Range S	Increment	Availability	Part Number	Price/pc.	
										A025.	€	
SH05	200E	1	5	M4	37	-	○	1,5 - 4,5	0,1	☐	SH05.0015 - .0045	a.A./POA
SH07	208E	1	7	M5	37	-	○	1,5 - 6,0	0,1	☐	SH07.0015 - .0060	a.A./POA
SH10	210E	2	10	7	40	4	○	3,0 - 3,5	0,5	■	SH10.0030 - .0035	27,30
								4,0 - 8,0			SH10.0040 - .0080	18,50
SH12	212E	2	12	8	40	4	○	3,0 - 3,5	0,5	■	SH12.0030 - .0035	28,80
								4,0 - 10,0			SH12.0040 - .0100	19,70
SH15	203E	2	15	11	40	6	○	3,0 - 3,5	0,5	■	SH15.0030 - .0035	30,50
								4,0 - 13,0			SH15.0040 - .0130	21,30
SH20	225E	2	20	14	65	8	○	3,0 - 5,5	0,5	■	SH20.0030 - .0055	33,20
								6,0 - 18,0			SH20.0060 - .0180	23,90
SH25	222E	2	25	20	65	8	○	4,0 - 5,5	0,5	■	SH25.0040 - .0055	34,20
								6,0 - 23,0			SH25.0060 - .0230	25,20
SH28	227E	2	28	20	65	8	○	3,0 - 27,0	0,5	☐	SH28.0030 - .0270	a.A./POA
								5,0 - 9,5			SH30.0050 - .0095	40,00
SH30	2	30	20	65	8	○	○	10,0 - 25,5	0,5	■	SH30.0100 - .0255	30,00
								26,0 - 28,0			SH30.0260 - .0280	40,00
								5,0 - 9,5			SH32.0050 - .0095	41,80
SH32	2	32	20	65	8	○	○	10,0 - 29,0	0,5	■	SH32.0100 - .0290	31,60
								29,5 - 30,0			SH32.0295 - .0300	41,80
								5,0 - 9,5			SH36.0050 - .0350	a.A./POA
SH36	2	36	20	65	8	○	○	5,0 - 35,0	0,5	■	SH36.0050 - .0350	a.A./POA
SH42	2	42	20	70	8	○	○	15,0 - 40,0	1,0	☐	SH42.0150 - .0400	81,40

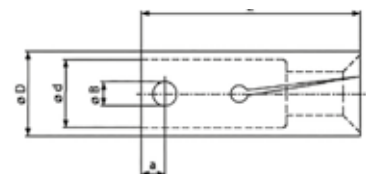
Bestellbeispiel:
Spannhülse SH25 (225E) Ø 10,0 mm
▷ Artikelnr. A025.SH25.0100

Ordering Example:
Guide Bush T223 Ø 13.0 mm
▷ Part No. A022.0223.0130

Auf Anfrage lieferbar:

- Spannhülsen für Turbo-Lademagazine
- Spannhülsen für Lademagazine mit Aufschraubgewinde
- Spanndorme/Innenspannhülsen für Rohre
- Spannhülsenlagerungen

Available on request:

- Bar feed collets for Turbo bar loaders
- Bar feed collets for bar loaders with thread
- Bar feed collets for internal grinding
- Revolving Ends



Spannköpfe für Einspindeldrehautomaten

Zum Spannen von Werkstücken auf Einspindel-Drehmaschinen. Lange Ausführung zum überwiegenden Einsatz auf der Hauptspindel, kurze Version vorwiegend auf der Gegenspindel zur Feinbearbeitung.
Hohe Spannkraft, kurze Umrüstzeiten.
Ca. 58-62 HRC.



Spannköpfe rund

Clamping Heads for Single Spindle Automatics

For clamping of workpieces in single spindle lathes. Long version mainly for main spindle use, short version mainly for use in the sub spindle for precision machining. High clamping forces, short changeover times. Approx. 58-62 HRC.

Clamping Heads round

Typ	Ø D	L	Innenprofil	Spannfläche	Spannbereich	Stg.	Verfügbark.	Preisgruppe/Price Group	Artikelnr.	Preis/St.
Type			Ins. Shape	Clamping Surface	Clamp. Range	Incr.	Availability		Part Number	Price/pc.
	mm	mm			mm					€
mit Vorbau (lange Version)				With Nose (long)						
SK42	79,3	47	○	Glatt Smooth	3,0 - 7,5	0,5	□		A030.0042.0040 - .0420	a.A./POA
				Querrillen Serrated	8,0 - 10,5				A030.0142.0080 - .0105	
				Quer-/Längsr. Double serr.	11,0 - 42,0				A030.0242.0110 - .0420	
SK65	99,5	58	○	Glatt Smooth	3,0 - 7,5	0,5	□		A030.0065.0030 - .0075	a.A./POA
				Querrillen Serrated	8,0 - 10,5				A030.0165.0080 - .0105	
				Quer-/Längsr. Double serr.	11,0 - 65,0				A030.0265.0110 - .0650	
SK80	114,5	-	○	Glatt Smooth	5,0 - 80,0	1,0	□		A030.0080.0050 - .0800	a.A./POA
				Querrillen Serrated	8,0 - 80,0				A030.0180.0080 - .0800	
				Quer-/Längsr. Double serr.	11,0 - 80,0				A030.0280.0110 - .0800	

Bestellbeispiel:
Spannkopf lang, rund, querrillt SK42 Ø 35 mm
▷ Artikelnr. A030.0142.0350

Ordering Example:
Clamping Head long, round, serrated SK42 Ø 35 mm
▷ Part No. A030.0042.0350

Auf Anfrage lieferbar:
- Manuelle Wechselvorrichtungen
- Spannfutter
- Ausdrehringe

Available on request:
- Manual changing devices
- Clamping head chucks
- Turning fixtures

Typ	Ø D	L	Innenprofil	Spannfläche	Spannbereich	Stg.	Verfügbark.	Preisgruppe/Price Group	Artikelnr.	Preis/St.
Type			Ins. Shape	Clamping Surface	Clamp. Range	Incr.	Availability		Part Number	Price/pc.
	mm	mm			mm					€
ohne Vorbau (kurze Version)				Without Nose (short)						
SK42	79,3	42	○	Glatt Smooth	3,0 - 42,0	0,5	□		A031.0042.0030 - .0420	a.A./POA
				Querrillen Serrated	8,0 - 42,0				A031.0142.0080 - .0420	
				Quer-/Längsr. Double serr.	11,0 - 42,0				A031.0242.0110 - .0420	
SK65	99,5	53	○	Glatt Smooth	4,0 - 65,0	0,5	□		A031.0065.0040 - .0650	a.A./POA
				Querrillen Serrated	8,0 - 65,0				A031.0165.0080 - .0650	
				Quer-/Längsr. Double serr.	11,0 - 65,0				A031.0265.0110 - .0650	
SK80	114,5	53	○	Glatt Smooth	5,0 - 80,0	1,0	□		A031.0080.0050 - .0800	a.A./POA
				Querrillen Serrated	8,0 - 80,0				A031.0180.0080 - .0800	
				Quer-/Längsr. Double serr.	11,0 - 80,0				A031.0280.0110 - .0800	

Spannköpfe SK32 (nur kurz)/52/100 auf Anfrage lieferbar!

Clamping Heads SK32 (short only) 52 / 100 available on request!

Sechs- und Vierkant-Spannköpfe

Hex and Square Clamping Head

Typ	L	Innenprofil	Spannfläche	Spannbereich	Stg.	Verfügbark.	Preisgruppe/Price Group	Artikelnr.	Preis/St.
Type		Inside Shape	Clamping Surface	Clamp. Range	Incr.	Availability		Part Number	Price/pc.
				mm	mm			Lang/Long = A030. Kurz/Short = A031.	€
SK42	Lang + Kurz/Long + Short	⬡	Glatt + Querrillen / Smooth + Serrated	7,0 - 68,0	1,0	□		0xxx.10xx - .1xxx	a.A./POA
SK65	Lang + Kurz/Long + Short	□	Glatt + Querrillen / Smooth + Serrated	8,0 - 56,0	1,0	□		0xxx.20xx - .2xxx	a.A./POA

Auf Anfrage lieferbar:
Weiche Spannköpfe, ausdrehbar

Soft Clamping Heads available on request



Spannköpfe für Mehrspindelautomaten

Zum Spannen von Werkstücken auf Mehrspindelautomaten der Marken Index, Schütte, Gildemeister, Mori Say, Wickmann



Clamping Heads for Multi Spindle Automatics

For clamping of workpieces in multi spindle automatics from Index, Schuette, Gildemeister, Mori Say, Wickmann

Spannköpfe rund

Clamping Head

Typ	Mehrspindel-Drehautom.	Ø D	L	Innenprofil	Spannfläche	Spannbereich	Stg.	Verfügbar.	Artikelnr.	Preis/St.
Type	Multi-Spindle Autom.			Ins. Shape	Clamping Surface	Clamp. Range	Incr.	Availability	Part Number	Price/pc.
		mm	mm			mm	mm		A032.	€

INDEX

MSK16I	MS16	44,3	36	○	Glatt	Smooth	4,0 - 7,0	1,0	<input type="checkbox"/>	0016.0040 - .0070	a.A./POA
					Querrillen	Serrated	8,0 - 10,0			0116.0080 - .0100	a.A./POA
					Quer-/Längsr.	Double serr.	11,0 - 22,0			0216.0110 - .0220	a.A./POA
MSK22I	MS18	44,3	36	○	Glatt	Smooth	4,0 - 22,0	1,0	<input type="checkbox"/>	0022.0040 - .0220	a.A./POA
					Querrillen	Serrated	8,0 - 10,0			0122.0080 - .0100	a.A./POA
					Quer-/Längsr.	Double serr.	11,0 - 22,0			0222.0110 - .0220	a.A./POA
MSK9022B	MS22	44,3	40	○	Glatt	Smooth	4,0 - 22,0	1,0	<input type="checkbox"/>	0922.0040 - .0220	a.A./POA
					Querrillen	Serrated	8,0 - 10,0			1922.0080 - .0100	a.A./POA
					Quer-/Längsr.	Double serr.	11,0 - 22,0			2922.0110 - .0220	a.A./POA
MSK9022	MS22	44,3	37	○	Querrillen	Serrated	4,0 - 22,0	1,0	<input type="checkbox"/>	3922.0040 - .0220	a.A./POA
					Glatt	Smooth	4,0 - 7,0			0032.0040 - .0070	a.A./POA
					Querrillen	Serrated	8,0 - 10,0			0132.0080 - .0100	a.A./POA
MSK32I	MS32	61	47,2	○	Querrillen	Serrated	8,0 - 10,0	1,0	<input type="checkbox"/>	0232.0110 - .0260	a.A./POA
					Quer-/Längsr.	Double serr.	11,0 - 26,0			0042.0040 - .0070	a.A./POA
					Glatt	Smooth	4,0 - 7,5			0042.0040 - .0070	a.A./POA
MSK42B	MS42	79,3	47	○	Querrillen	Serrated	8,0 - 10,5	0,5	<input type="checkbox"/>	0142.0080 - .0100	a.A./POA
					Quer-/Längsr.	Double serr.	11,0 - 42,0			0242.0110 - .0260	a.A./POA
					Glatt	Smooth	4,0 - 7,5			0065.0040 - .0070	a.A./POA
MSK65B	MS52	99,5	58	○	Querrillen	Serrated	8,0 - 10,5	0,5	<input type="checkbox"/>	0165.0080 - .0100	a.A./POA
					Quer-/Längsr.	Double serr.	11,0 - 65,0			0265.0110 - .0260	a.A./POA
					Glatt	Smooth	4,0 - 7,0				

Auf Anfrage lieferbar:
 - Spannköpfe mit Hartmetallbeschichtung oder -einsatz
 - Spannköpfe in Sechskant und Vierkantausführung

Available on request:
 - Carbide coated clamping heads or with carbide insert
 - Hex and square clamping heads

INDEX / SCHÜTTE

MSK39	INDEX MS25 SCHÜTTE SF25 •SE26•AF26•SF26 •SF26S•SC26•SCx26	60,5	38	○	Glatt	Smooth	4,0 - 7,0	1,0	<input type="checkbox"/>	0039.0040 - .0070	a.A./POA
					Querrillen	Serrated	8,0 - 10,0			0139.0080 - .0100	a.A./POA
					Quer-/Längsr.	Double serr.	11,0 - 26,0			0239.0110 - .0260	a.A./POA

SCHÜTTE / GILDEMEISTER / MORI SAY

MSK69B	SCHÜTTE SF32 •SF32S•AF32 •AF32S•S32PC GILDEMEISTER AS32S•GS32•GM32 MORI SAY 6-26	69,8	43	○	Glatt	Smooth	4,0 - 32,0	1,0	<input type="checkbox"/>	0069.0040 - .0070	a.A./POA
					Querrillen	Serrated	8,0 - 10,0			0169.0080 - .0100	a.A./POA
					Quer-/Längsr.	Double serr.	11,0 - 32,0			0269.0110 - .0260	a.A./POA

WICKMANN

MSK34	9034	54,4		○	Glatt	Smooth	4,0 - 7,0	1,0	<input type="checkbox"/>	0034.0040 - .0070	a.A./POA
					Querrillen	Serrated	8,0 - 10,0			0134.0080 - .0100	a.A./POA
					Quer-/Längsr.	Double serr.	11,0 - 26,0			0234.0110 - .0260	a.A./POA

Bestellbeispiel:
 Spannkopf rund, querrillt für Index MS25 MSK39 Ø 10 mm
 ▷ Artikelnr. **A032.0139.0100**

Ordering Example:
 Clamping Head round, serrated for Index MS25 MSK39 Ø 10 mm
 ▷ Part No. **A032.0139.0100**



Mehrspindler-Spannzangen

Multi-Spindle Collets

Typ	Mehrspindel-Drehautom.	Abb.	d	D	L	α	Gewinde	Ø max.	Verfügbark.	Artikelnr.	Preis/St.
Type	Multi-Spindle Autom.	Fig.	mm	mm	mm		Thread	mm	Availability	Part Number	Price/pc.
Preisgruppe/Price Group											
PG 165											
A009.											
€											

GILDEMEISTER

9013E	AS12	1	26,8	34	88	15°	M24 x 1,0 L	13	<input type="checkbox"/>	9013.0xxx
9012E	AS16/20/GS/GM20	1	34	42,3	90	16°	M30 x 1,0 L	20	<input type="checkbox"/>	9012.0xxx
9017E	AS20 e. 25/GM20 erw.	2	38	45,5	90	16°	M34.5 x 0,75 L	25	<input type="checkbox"/>	9017.0xxx
9045E	AS25	2	45	60,4	164	15°	M40 x 1,0 L	25	<input type="checkbox"/>	9045.0xxx
9046E	GS25	2	45	60,4	164	15°	M40 x 1,5 L	25	<input type="checkbox"/>	9046.0xxx
9069E	AS/AV/GM32/GM35	2	53	69,4	139	15°	M48 x 1,5 L	32	<input type="checkbox"/>	9069.0xxx
9081E	GS35/36/42	2	56	72,4	137	15°	M52 x 1,5 L	35	<input type="checkbox"/>	9081.0xxx
9115E	GM42	2	64	80,5	134	15°	M59 x 1,5 L	42	<input type="checkbox"/>	9115.0xxx
9132E	AA/AR/AS/AV48	2	70	90,4	167,5	15°	M65 x 1,5 L	48	<input type="checkbox"/>	9132.0xxx
9178E	AS/AV67	2	90	115,4	183,5	15°	M85 x 1,5 L	67	<input type="checkbox"/>	9178.0xxx
9209E	AS82	2	109	138,4	201	15°	M102 x 1,5 L	82	<input type="checkbox"/>	9209.0xxx
9239E	AS100	2	128	160,4	263	15°	M122 x 1,5 L	100	<input type="checkbox"/>	9239.0xxx

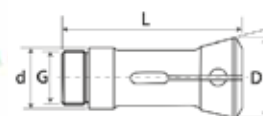

a.A./POA

Abb.1/Fig.1

INDEX

9007E	MS16	1	32	41,5	84	15°	M28 x 1,0 L	18	<input type="checkbox"/>	9007.0xxx
9033E	KS20/KS22	1	40	55,2	102	15°	M35 x 1,5 R.o.L	22	<input type="checkbox"/>	9033.0xxx
9039E	KS25/MS25	3	46	60,5	112	16°	M40 x 1,5 L	25	<input type="checkbox"/>	9039.0xxx
9070E	KS32	1	53	69,3	136	15°	M47 x 1,5 L	32	<input type="checkbox"/>	9070.0xxx
9108E	KS42	1	62	82,4	180	15°	M58 x 1,5 L	42	<input type="checkbox"/>	9108.0xxx
9133E	KS50	1	70	92	157	15,5°	M65 x 2,0 L	50	<input type="checkbox"/>	9108.0xxx

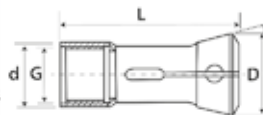

a.A./POA

Abb.2/Fig.2

SCHÜTTE

9015E	SF13	1	25	36,2	72	15°	M22 x 1,0 L	13	<input type="checkbox"/>	9015.0xxx
9007E	SE/SF16/SE18	1	32	41,5	84	15°	M28 x 1,0 L	18	<input type="checkbox"/>	9007.0xxx
9016E	SF20/VD20	1	32	41,5	84	15°	M30 x 1,0 L	20	<input type="checkbox"/>	9016.0xxx
9049E	SD/SE/VD25/AF/SE/SF26	1	46	60,3	120	15°	M40 x 1,5 L	26	<input type="checkbox"/>	9039.0xxx
9070E	AF/AV/SD/SF/VD32	1	53	69,3	136	15°	M47 x 1,5 L	32	<input type="checkbox"/>	9070.0xxx
9112E	SD/SF40/SF42	1	62,9	78,3	157	15°	M56 x 1,5 L	42	<input type="checkbox"/>	9112.0xxx
9139E	SD/VD50/AF/SF51	1	75	97,8	187	15°	M68 x 1,5 L	51	<input type="checkbox"/>	9139.0xxx
9179E	SD/VD63	1	90	115,8	211	15°	M82 x 1,5 L	63	<input type="checkbox"/>	9179.0xxx
9187E	AF/SF67	2	89,9	115,4	180	15°	M85 x 1,5 L	67	<input type="checkbox"/>	9187.0xxx
9210E	SD/VD80/AF/SF81	1	109	138,3	241	15°	M100 x 1,5 L	81	<input type="checkbox"/>	9210.0xxx

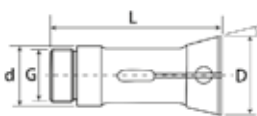

a.A./POA

Abb.3/Fig.3

TORNOS

9001E	AS14/BS14	2	25	35	75	16°	M22 x 1	14	<input type="checkbox"/>	9001.0xxx
9021E	AS16/SAS16	1	25	35	94	15°30'	M25 x 1	16	<input type="checkbox"/>	9021.0xxx
9018E	BS20/22	1	35	45	107	15°30'	M33 x 1	23	<input type="checkbox"/>	9018.0xxx
9020E	BS20B	2	36	45	107	15°30'	M33 x 1,25	20	<input type="checkbox"/>	9020.0xxx
9012E	Multi Deco 20-6/-8	1	34	42	90	16°	M30 x 1 L	20	<input type="checkbox"/>	9012.0xxx
9049E	Multi Deco 26-6	1	46	60,3	120	15°	M40 x 1,5 L	30	<input type="checkbox"/>	9039.0xxx
9081E	SAS36	2	56	72,4	139	15°	M52 x 1,5 L	36	<input type="checkbox"/>	9081.0xxx

Sechs- und Vierkant-Ausführung auf Anfrage lieferbar!

Hexagon and square collets available on request!

Bestellbeispiel
Mehrspindler-Spannzange für Index KS32 Ø 26,0 mm
▷ Artikelnr. **A009.9070.0260**

Ordering Example:
Multi-Spindle Collet for Index KS32 Ø 26.0 mm
▷ Part No. **A009.9070.0260**

Mehrspindel-Vorschubzangen

Multi-Spindle Feed Fingers

Preisgruppe/Price Group									PG 165	
Typ	Mehrspindel-Drehautom.	Abb.	d	D	L	Gewinde	Ø max.	Verfügbar.	Artikelnr.	Preis/St.
Type	Multi-Spindle Autom.	Fig.	mm	mm	mm	Thread	mm	Availability	Part Number	Price/pc.
									A009.	€

GILDEMEISTER

9259E	AS12	2	17,5	19,5	82	M17 x 1	13	<input type="checkbox"/>	9259.0xxx
9258E	AS16/AS20/GM20	1	25	25	90	M24 x 1	20	<input type="checkbox"/>	9258.0xxx
9288E	AS20 erw.25	1	30	30,5	90	M28,5 x 0,75	25	<input type="checkbox"/>	9288.0xxx
9287E	AS25	1	32,5	33	140	M30 x 1 L	25	<input type="checkbox"/>	9287.0xxx
9289E	GS25	1	30	34,2	140	M30 x 1	25	<input type="checkbox"/>	9289.0xxx
9316E	AS32/AV32	1	39,8	40	136	M38 x 1,5 L	32	<input type="checkbox"/>	9316.0xxx
9335E	GM32 erw. 35/GM35	1	41	41,2	136	M39 x 1 L	35	<input type="checkbox"/>	9335.0xxx
9336E	GM32	1	40	41,2	136	M38 x 1,5 R o. L	32	<input type="checkbox"/>	9336.0xxx
9333E	GS35	1	43,8	45	136	M42 x 1,5 L	35	<input type="checkbox"/>	9333.0xxx
9374E	GM42	1	50,2	51,5	136	M48 x 1,5	42	<input type="checkbox"/>	9374.0xxx
9368E	AA/AR/AS/AV48	1	56	57	136	M54 x 1,5 L	48	<input type="checkbox"/>	9368.0xxx
9447E	AS67	1	76	77,5	170	M74 x 1,5 L	67	<input type="checkbox"/>	9447.0xxx
9475E	AS/AV82	1	93	94	180	M88 x 1,5 L	82	<input type="checkbox"/>	9475.0xxx
9483E	AS100	1	113	114	235	M108 x 1,5 L	100	<input type="checkbox"/>	9483.0xxx



a.A./POA



Abb.1/Fig.1

INDEX

9255E	MS16	1	23	25	88	M23 x 1	19	<input type="checkbox"/>	9255.0xxx
9273E	KS20/KS22	1	28	30,8	102	M28 x 1,5 R o. L	22	<input type="checkbox"/>	9273.0xxx
9282E	KS25/MS25	1	33	37	118	M33 x 1,5	25	<input type="checkbox"/>	9282.0xxx
9319E	KS32	1	40	41,8	130	M38 x 1,5	32	<input type="checkbox"/>	9319.0xxx
9364E	KS42	1	50	54	170	M50 x 1,5 L	42	<input type="checkbox"/>	9364.0xxx
9402E	KS50	1	57	60	156	M57 x 2 L	50	<input type="checkbox"/>	9402.0xxx

a.A./POA

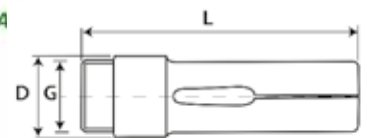

Abb.2/Fig.2

SCHÜTTE

9261E	SF13	1	17	19,6	82	M18 x 1	13	<input type="checkbox"/>	9261.0xxx
9255E	SE16/SE18	1	23	25	88	M23 x 1	16	<input type="checkbox"/>	9255.0xxx
9262E	SF20/VD20	1	25	27	88	M25 x 1	20	<input type="checkbox"/>	9262.0xxx
9282E	SD/SE/VD25/AF/SE/SF26	1	33	35	118	M33 x 1,5	25	<input type="checkbox"/>	9282.0xxx
9319E	AF/AV/SD/SF/VD32	1	40	41,8	130	M38 x 1,5	32	<input type="checkbox"/>	9319.0xxx
9372E	SD/SF40/SF42	1	51	51	174	M48 x 1,5	42	<input type="checkbox"/>	9372.0xxx
9406E	SD/SF50/SF51	1	58	62	195	M58 x 1,5	50	<input type="checkbox"/>	9406.0xxx
9450E	SD/VD63	1	72	77	205	M72 x 1,5 L	63	<input type="checkbox"/>	9450.0xxx
9456E	AF/SF67	2	76	78	225	M75 x 1,5 L	69	<input type="checkbox"/>	9456.0xxx
9474E	SD/VD80/AF/SF81	1	90	92,8	233	M88 x 1,5 L	80	<input type="checkbox"/>	9474.0xxx

a.A./POA

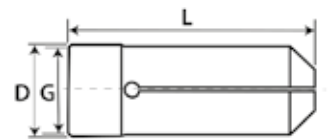
Sechs- und Vierkant-Ausführung auf Anfrage lieferbar!

Hexagon and square collets available on request!

TORNOS

9251E	AS14/BS14	1	17,5	18	70	M16 x 0,75	14	<input type="checkbox"/>	9251.0xxx
9265E	AS16/SAS16	1	20,5	22,8	98	M20 x 0,75	16	<input type="checkbox"/>	9265.0xxx
9263E	BS20/BS22	1	29	29,7	116	M27 x 1	23	<input type="checkbox"/>	9263.0xxx
9266E	BS20B	1	25,3	27,7	116	M25 x 1	21	<input type="checkbox"/>	9266.0xxx
9258E	Multi Deco 20-6/-8	1	30,5	30,5	90	M28 x 0,75	20	<input type="checkbox"/>	9258.0xxx
9282E	Multi Deco 26-6	1	33	35	118	M33 x 1,5	25	<input type="checkbox"/>	9282.0xxx

a.A./POA

a.A./POA

Bestellbeispiel:

Vorschubzange für Gildemeister GS25 Ø 20,0 mm
▷ Artikelnr. **A009.9285.0200**

Ordering Example:

Feed finger for Gildemeister GS25 Ø 20.0 mm
▷ Part No. **A009.9285.0200**

Vorschubzangen für andere Hersteller (Pittler, Wickmann, ZPS u.a.) oder andere Maschinentypen auf Anfrage lieferbar!

Feed fingers for different manufacturers (Pittler, Wickmann, ZPS a.o.) or different machine types available on request!



Mehrspindler-Greifzangen

Multi-Spindle Pick-off Collets

Typ	Mehrspindel-Drehautom.	Abb.	D	L	d	Gewinde	Verfügbar.	Artikelnr.	Preis/St.
Type	Multi-Spindle Autom.	Fig.				Thread	Availability	Part Number	Price/pc.
	mm		mm	mm	mm	G		A009.	€

GILDEMEISTER

1292E	AS/GS20 Pinolenzange	1	26	56,5	20	-	<input type="checkbox"/>	1292.0xxx	a.A./POA
3560E	AS16/AS20/GS20	2	28,5	80,0	26	M21,5 x 0,75	<input type="checkbox"/>	3560.0xxx	
3655E	AS16/20 - AS22/25	2	35,1	63,0	30	M20 x 1,5	<input type="checkbox"/>	3655.0xxx	
3762E	AV/AS/GS32 - GS36/42	3	43	80,0	38	M24 x 1,5 L	<input type="checkbox"/>	3762.0xxx	
3865E	GM42	7	52,5	68,0	47	Bajonett	<input type="checkbox"/>	3865.0xxx	
3862E	AA/AR/AS/AV48		55	91,0	42	M28 x 1,5	<input type="checkbox"/>	3862.0xxx	
3857E	AS/AV67		90,1	100,0	45	M28 x 1,5	<input type="checkbox"/>	3857.0xxx	
3939E	AV/AS82	3	105	130,0	60	M40 x 1,5	<input type="checkbox"/>	3939.0xxx	
3940E	AS100	3	120,1	130,0	60	M40 x 1,5	<input type="checkbox"/>	3940.0xxx	

INDEX

9039E	MS25	1	35,4	65,0	25	-	<input type="checkbox"/>	9039.0xxx	a.A./POA
9108E	KS32/42/50	1	49	49,8	36	M28 x 1,5 L	<input type="checkbox"/>	9108.0xxx	

SCHÜTTE

3380E	SF13	3	24	38,3	20	M16 x 1,5 L	<input type="checkbox"/>	3380.0xxx	a.A./POA
3540E	SE16/SE18	3	35,1	58,0	25	M18 x 1,5 L	<input type="checkbox"/>	3540.0xxx	
3607E	SF20	3	36	50,0	28	M24 x 1,5 L	<input type="checkbox"/>	3607.0xxx	
3722E	SD/SE/VD25	3	45,1	71,0	32	M22 x 1,5 L	<input type="checkbox"/>	3722.0xxx	
1495E	AF/SE/SF26	4	42	53,0	34	-	<input type="checkbox"/>	1495.0xxx	
3790E	SD/VD32	3	50,6	81,0	39	M26 x 1,5 L	<input type="checkbox"/>	3790.0xxx	
1700E	AF/SF32 SF40/42	4	60,6	60,0	52	-	<input type="checkbox"/>	1700.0xxx	
3863E	SD/VD50	3	67,2	83,0	46	M32 x 1,5 L	<input type="checkbox"/>	3863.0xxx	
1777E	AF/SF51	4	71,6	60,0	63	-	<input type="checkbox"/>	1777.0xxx	
3914E	SD/VD63	3	88,9	90,0	55	M42 x 1,5 L	<input type="checkbox"/>	3914.0xxx	
1843E	AF/SF67/SF81	4	88	75,0	76	-	<input type="checkbox"/>	1843.0xxx	
3917E	SD/VD80	3	108	90,0	55	M42 x 1,5 L	<input type="checkbox"/>	3917.0xxx	

FORNOS

3263E	AS14/SAS16	5	21	58	16	M14 x 0,75	<input type="checkbox"/>	3263.0xxx	a.A./POA
3541E	BS20B	6	35	77	25	M22 x 1	<input type="checkbox"/>	3541.0xxx	
3601E	Multi Deco 20-6/8	7	32	68	28	Bajonett	<input type="checkbox"/>	3601.0xxx	a.A./POA
1757E	Multi Deco 26/32-6	7	40	75	35,5	Bajonett	<input type="checkbox"/>	3757.0xxx	
171E	SAS36		55	94	42		<input type="checkbox"/>	0171.0xxx	

Bestellbeispiel

Greiferzange für Schütte SF20
 Ø 12,0 mm
 ▷ Artikelnr. **A009.3607.0120**

Ordering Example:

Pick-off collet for Schütte SF20
 Ø 12.0 mm
 ▷ Part No. **A009.3607.0120**

Greiferzangen für andere Hersteller (Pittler, Wickmann, ZPS u.a.) oder andere Maschinentypen auf Anfrage lieferbar!

Pick-off collets for different manufacturers (Pittler, Wickmann, ZPS a.o.) or different machine types available on request!



Abb.1/Fig.1



Abb.2/Fig.2

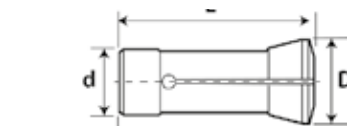

Abb.3/Fig.3

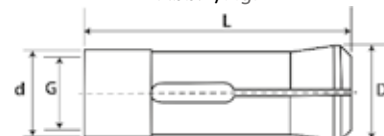

Abb.4/Fig.4

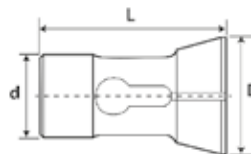

Abb.5/Fig.5

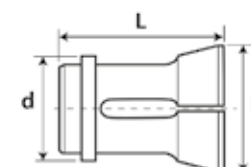

Abb.6/Fig.6

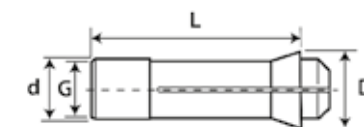

Abb.7/Fig.7

Vorschubzangen (Reihe 200)

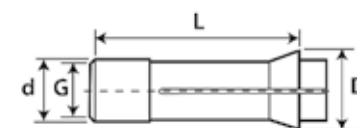
Zum Vorschub des Stangenmaterials in Drehautomaten.
Glatte Ausführung.

Innenvorschubzangen rund

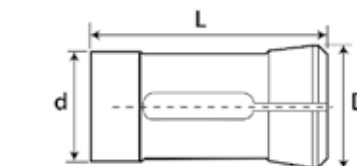
								Preisgruppe/Price Group	PG 201
Typ	D	L	Gewinde G	Innenprofil	Spannbereich	Steigung	Verfügbark.	Artikelnr.	Preis/St.
Type	mm	mm	Thread G	Ins. Shape	Clamp. Range	Increment	Availability	Part Number	Price/pc.
								A002.	€
207E	18	70	M16 x 1 L	○	1,0 - 2,5 3,0 - 12,0	0,5	■	0207.0010 - .0025 0207.0030 - .0120	a.A./POA
217E	21	70	M20 x 1 L	○	3,0 - 16,0	0,5	□	0217.0030 - .0160	a.A./POA
220E	24	85	M22 x 1 L	○	3,0 - 18,0	0,5	■	0220.0030 - .0180	a.A./POA
236E	30	95	M28 x 1 L	○	3,0 - 24,0	0,5	■	0236.0030 - .0240	a.A./POA
237E	31	90	M29 x 1 L	○	3,0 - 25,0	0,5	■	0237.0030 - .0250	a.A./POA
254E	42	116	M40 x 1 L	○	4,0 - 36,0	0,5	■	0254.0040 - .0360	a.A./POA
273E	60	140	M58 x 1 L	○	10,0 - 52,0	0,5	□	0273.0100 - .0520	a.A./POA

Bestellbeispiel:
Innenvorschubzange 220E Ø 18,0 mm
▷ Artikelnr. A002.0220.0180

Feed Fingers (Series 200)

For feeding the bar material in single-spindle automatic lathes. Smooth bore.

Internal Feed Fingers Round



Ordering Example:
Internal Feed Finger 220E Ø 18,0 mm
▷ Part No. A002.0220.0180

Sechs- und Vierkant-Innenvorschubzangen

							Preisgruppe/Price Group	PG 201
Typ	D	L	Gewinde G	Innenprofil	Spannbereich (SW)	Verfügbark.	Artikelnr.	Preis/St.
Type	mm	mm	Thread G	Ins. Shape	Clamping Range (WAF)	Availability	Part Number	Price/pc.
							A001.	€
207E	18	70	M16 x 1 L	⬡	4 - 11	□	0207.1040 - .1110	a.A./POA
				□	4 - 9	□	0207.2040 - .2090	a.A./POA
217E	21	70	M20 x 1 L	⬡	5 - 14	□	0217.1050 - .1140	a.A./POA
				□	6 - 11	□	0217.2060 - .2110	a.A./POA
220E	24	85	M22 x 1 L	⬡	4 - 16	■	0220.1040 - .1160	a.A./POA
				□	5 - 12	□	0220.2050 - .2120	a.A./POA
236E	30	95	M28 x 1 L	⬡	4 - 21	■	0236.1040 - .1210	a.A./POA
				□	7 - 16	■	0236.2070 - .2160	a.A./POA
237E	31	90	M29 x 1 L	⬡	4 - 22	■	0237.1040 - .1220	a.A./POA
				□	5 - 18	■	0237.2050 - .2180	a.A./POA
254E	42	116	M40 x 1 L	⬡	10 - 31	■	0254.1100 - .1310	a.A./POA
				□	10 - 25	□	0254.2100 - .2250	a.A./POA

Bestellbeispiel:
Sechskant-Vorschubzange 207E SW 8 mm
▷ Artikelnr. A002.0207.1080

Ordering Example:
Hex Internal Feed Finger 207E WAF 8 mm
▷ Part No. A002.0207.1080



Außenvorschubzangen rund

								Preisgruppe/Price Group	PG 201
Typ	D	L	Gewinde G	Innenprofil	Spannbereich	Steigung	Verfügbark.	Artikelnr.	Preis/St.
Type	mm	mm	Thread G	Ins. Shape	Clamp. Range	Increment	Availability	Part Number	Price/pc.
								A002.	€
242E	42	120	M36 x 1,5	○	25,0 - 30,0	1,0	□	0242.0250 - .0300	a.A./POA
259E	56	138	M50 x 1,5	○	37,0 - 42,0	1,0	□	0259.0370 - .0420	a.A./POA
278E	75	138	M68 x 1,5	○	53,0 - 60,0	1,0	□	0278.0530 - .0600	a.A./POA

Bestellbeispiel:
Außenvorschubzange 242E Ø 26,0 mm
▷ Artikelnr. A002.0242.0260
6-kant/4-kant auf Anfrage lieferbar!

Ordering Example:
External Feed Finger 242E Ø 26,0 mm
▷ Part No. A002.0242.0260
Hex/square are available on request!

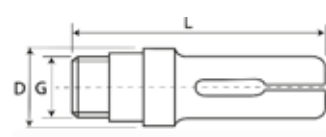

Zugspannzangen DIN 6341 (Reihe 300)

Zum Spannen von Werkstücken in Teilapparaten, Schleifmaschinen oder Nachdrehbänken.

Rundlaufgenauigkeit nach DIN 6341

Ø d	l	Rundlauf Standard	erhöhter Rundlauf
mm	mm	Run-out Standard	Run-out High Acc.
mm	mm	mm	mm
1,0 - 1,6	6	0,02	0,015
1,6 - 3,0	10		
3,0 - 6,0	16		
6,0 - 10,0	25		
10,0 - 18,0	40		
18,0 - 24,0	50	0,03	0,020
24,0 - 30,0	60		
30,0 - 50,0	80	0,04	0,030
> 50,0	100		

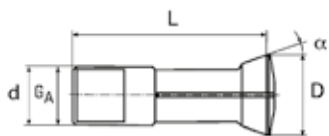

Draw-In Collets DIN 6341 (Series 300)

For clamping of workpieces in indexing devices, grinding machines or second-operation lathes.

Run-Out Accuracy acc. to DIN 6341

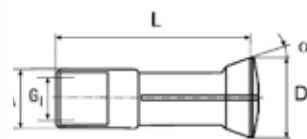
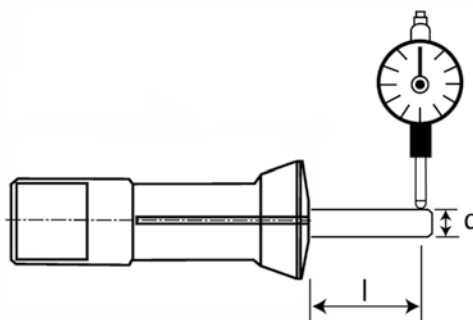

385E (5C)

Technische Daten

Typ	Spannbereich	Steigung*	d	L	D	α	GA	GI
Type	Clamp. Range	Increment*	mm	mm	mm			
	mm	mm	mm	mm	mm			
302E	1,0 - 6,0	0,5	8,0	35,00	12,7	20°	W6,85x40Gg	
314E	1,0 - 10,0	0,5	10,0	43,70	14,0	15°	M9,83x0,8333	
318E	1,0 - 10,0	0,5	12,0	45,60	16,0	15°	S11,75x1,25	
319E	1,5 - 10,0	0,5	12,0	62,20	18,0	20°	Tr12x1	
321E	1,5 - 12,0	0,5	15,0	58,30	20,2	20°	S14,75x1,25	
324E	1,5 - 13,0	0,5	15,0	55,50	21,5	20°	M13x1	
330E	1,5 - 13,0	0,5	16,0	72,80	24,0	20°	Tr16x1,5	
349E	1,5 - 20,0	0,5	20,0	69,00	26,3	15°	S19,7x1,666	
351E	1,5 - 17,5	0,5	20,0	83,00	28,0	20°	Tr20x1,5	
355E	1,0 - 18,0	0,5	20,0	117,50	28,0	17,5°	S19,7x2	
358E	1,5 - 20,0	0,5	23,0	82,00	32,0	20°	M21,2x1	
359E	1,0 - 20,0	0,5	23,0	90,00	32,0	20°	Tr23x1,5	
362E	3,0 - 22,0	0,5	25,0	89,00	34,0	15°	M21,2x1	
363E	1,5 - 22,0	0,5	25,0	85,00	33,5	16°	M23x1	
364E	1,5 - 22,0	0,5	25,0	92,50	33,7	15°	S25x1	
366E	1,5 - 25,0	0,5	28,0	102,00	36,0	18°	Tr27x1/20"	
367E	1,5 - 24,0	0,5	28,0	100,00	38,0	20°	Tr28x1,5	
369E	2,0 - 22,0	0,5	24,12	101,50	31,75	8,5°	7/16"x1/20"	
385E	1,0 - 26,0	0,5	31,8	83,00	37,5	10°	31,45x1/20"	26,5x1/24"
386E	1,0 - 29,0	0,5	32,0	110,00	45,0	20°	Tr32x1,5	
3713E	3,0 - 32,0	0,5	32,0	106,00	40,0	15°	29,7x1,693	
B45	4,0 - 45,0	0,5	45,0	115,00	53,0	15°	M42x1,5	
389E	5,0 - 40,0	1,0	45,0	140,00	60,0	20°	Tr45x2	
390E	5,0 - 42,0	1,0	47,0	115,00	60,0	20°	Tr47x1,5	

Technical Data

Alle nicht gelisteten
Zugspannzangentypen
sind auf Anfrage lieferbar.

Not listed types of drawin
collets are available on
request.



Zugspannzangen rund DIN 6341

Draw-In Collets Round DIN 6341

Typ Type	Bezeichnung Description	Innenprofil Ins. Shape	Spannbereich Clamp. Range mm	Steigung Increment mm	Verfügbark. Availability	Preisgruppe/Price Group	PG 301
						Artikelnr. Part Number A003.	Preis/St. Price/pc. €
302E	B8 72-137	○	1,0	-	■	0302.0010	35,00
			1,5-2,5	0,5	■	0302.0015 - .0025	35,00
			3,0 - 6,0		■	0302.0030 - .0060	27,25
314E	W10 80-1	○	1,0 - 2,5	0,5	□	0314.0010 - .0025	a.A./POA
			3,0 - 10,0		□	0314.0030 - .0100	a.A./POA
318E	W12 80-2	○	1,0	-	■	0318.0010	35,00
			1,5-2,5	0,5	■	0318.0015 - .0025	30,00
			3,0 - 10,0		■	0318.0030 - .0100	25,00
319E	K12	○	1,0	-	■	0319.0010	38,00
			1,5-2,5	0,5	■	0319.0015 - .0025	36,50
			3,0 - 10,0		■	0319.0030 - .0100	29,75
321E	W15 80-3	○	1,5 - 2,5	0,5	□	0321.0015 - .0025	a.A./POA
			3,0 - 12,0		□	0321.0030 - .0120	a.A./POA
324E	B15 72-139	○	1,0	-	■	0324.0010	34,50
			1,5-2,5	0,5	■	0324.0015 - .0025	31,50
			3,0 - 13,0		■	0324.0030 - .0130	23,75
330E	K16	○	1,5 - 2,5	0,5	□	0330.0015 - .0025	a.A./POA
			3,0 - 13,0		□	0330.0030 - .0130	a.A./POA
349E	W20 80-4	○	1,0	-	■	0349.0010	31,25
			1,5-2,5	0,5	■	0349.0015 - .0025	28,75
			3,0 - 20,0		■	0349.0030 - .0200	22,50
351E	K20	○	1,0	-	■	0351.0010	40,50
			1,5-2,5	0,5	■	0351.0015 - .0025	38,75
			3,0 - 17,5		■	0351.0030 - .0175	33,75
355E	L20 77-122	○	1,0	-	■	0355.0010	40,50
			1,5-2,5	0,5	■	0355.0015 - .0025	39,25
			3,0 - 18,0		■	0355.0030 - .0180	32,00
358E	B23	○	1,0	-	■	0358.0010	38,75
			1,5-2,5	0,5	■	0358.0015 - .0025	36,25
			3,0 - 20,0		■	0358.0030 - .0200	30,00
359E	K23	○	1,0	-	■	0359.0010	41,25
			1,5-2,5	0,5	■	0359.0015 - .0025	39,75
			3,0 - 20,0		■	0359.0030 - .0200	32,50
362E		○	3,0 - 22,0	0,5	□	0362.0030 - .0220	a.A./POA
363E	B25	○	1,0	-	■	0363.0010	48,00
			1,5-2,5	0,5	■	0363.0015 - .0025	45,00
			3,0 - 22,0		■	0363.0030 - .0220	38,25
364E	W25 80-5	○	1,0	-	■	0364.0010	39,50
			1,5-2,5	0,5	■	0364.0015 - .0025	37,50
			3,0 - 22,0		■	0364.0030 - .0220	28,00
366E		○	1,0	-	■	0366.0010	47,00
			1,5-2,5	0,5	■	0366.0015 - .0025	45,00
			3,0 - 25,0		■	0366.0030 - .0250	37,50



Andere Zugspannzangentypen sind auf Anfrage lieferbar.

Other types of draw-in collets are available on request.

Fortsetzung auf Seite 22 / continued on page 22

Bestellbeispiel:

Zugspannzange 355E Ø 16,5 mm

▷ Artikelnr. A001.0355.0165

Ordering Example:

Draw-in Collet 355E Ø 16.5 mm

▷ Part No. A001.0355.0165



Zugspannzangen rund DIN 6341

Draw-In Collets Round DIN 6341

Fortsetzung von Seite 21 / continued from page 21

Typ Type	Bezeichnung Description	Innenprofil Ins. Shape	Spannbereich Clamp. Range	Steigung Increment	Verfügbark. Availability	Preisgruppe/Price Group	PG 301
						Artikelnr. Part Number	Preis/St. Price/pc.
						A003.	€
367E	K28	○	1,0	-	■	0367.0010	45,00
			1,5-2,5	0,5		0367.0015 - .0025	42,50
			3,0 - 24,0			0367.0030 - .0240	37,50
369E	R8	○	2,0 - 2,5	0,5	■	0369.0020 - .0025	25,25
			3,0 - 22,0			0369.0030 - .0220	20,00
385E	5C / W31	○	1,0	-	■	0385.0010	32,50
			1,5-2,5	0,5		0385.0015 - .0025	30,50
			3,0 - 26,0			0385.0030 - .0260	25,00
386E	K32	○	1,0	-	■	0386.0010	49,50
			1,5-2,5	0,5		0386.0015 - .0025	45,75
			3,0 - 29,0			0386.0030 - .0290	42,50
3713E	B32 72-65	○	3,0 - 32,0	0,5	□	3713.0030 - .0320	54,75
B45	B45 72-199	○	4,0 - 45,0	0,5	□	3845.0040 - .0450	a.A./POA
389E	K45	○	5,0 - 40,0	1,0	□	0389.0050 - .0400	a.A./POA
390E		○	5,0 - 42,0	1,0	□	0390.0050 - .0420	a.A./POA



Andere Zugspannzangentypen sind auf Anfrage lieferbar.

Other types of draw-in collets are available on request.

Bestellbeispiel:
Zugspannzange 367E rund Ø 12,0 mm
▷ Artikelnr. A001.0355.0165

Ordering Example:
Draw-in Collet 367E round Ø 12,0 mm
▷ Part No. A003.0367.0120

Sechs- und Vierkant-Zugspannzangen rund DIN 6341

Hex and Square Draw-in Collets DIN 6341

Typ Type	Bezeichnung Description	Innenprofil Ins. Shape	Spannbereich (SW) Clamping Range (WAF)	Verfügbark. Availability	Preisgruppe/Price Group	PG 301
					Artikelnr. Part Number	Preis/St. Price/pc.
					A003.	€
349E	W20 80-4	○	4 - 12	□	0349.1040 - .1120	47,50
		□	4 - 10	■	0349.2040 - .2100	47,50
355E	L20 77-122	○	4 - 11	□	0355.10xx - .1xxx	70,00
		□	4 - 9	■	0355.20xx - .2xxx	70,00
358E	B23	○	4 - 13	□	0358.10xx - .1xxx	61,00
		□	4 - 11	■	0358.20xx - .2xxx	61,00
359E	K23	○	4 - 16	□	0359.10xx - .1xxx	57,50
		□	4 - 13	■	0359.20xx - .2xxx	57,50
366E		○	4 - 18	■	0366.10xx - .1xxx	72,50
		□	4 - 14		0366.20xx - .2xxx	72,50
367E	K28	○	4 - 19	■	0367.10xx - .1xxx	67,50
		□	4 - 16		0367.20xx - .2xxx	67,50
385E	5C W31	○	5 - 21	■	0385.10xx - .1xxx	52,50
		□	4 - 18		0385.20xx - .2xxx	52,50
386E	K32	○	4 - 23	■	0386.10xx - .1xxx	82,50
		□	4 - 19		0386.20xx - .2xxx	82,50



Alle nicht gelisteten Zugspannzangentypen sind auf Anfrage lieferbar.

Not listed types of draw-in collets are available on request.

Bestellbeispiel:
Zugspannzange 386 E
Sechskant SW 13,0 mm
▷ Artikelnr. A003.0386.1130

Ordering Example:
Draw-in Collet 386E Hexagon 13,0 mm
▷ Part No. A003.0386.1130

Vorbau-Zugspannzangen

Extended Nose Draw-In Collets

Technische Daten

Technical Data

Typ	Spannbereich	Steigung	d	D	L	α	G _A
Type	Clamp. Range	Increment					
	mm	mm	mm	mm	mm		
349E	1,0 - 16,0	0,5	20	26,3	84,5	15°	∅ 19,7x1,667 ± 45°/5°
349E	1,0 - 20,0	0,5	20	26,3	84,5	15°	∅ 19,7x1,667 ± 45°/5°
364E	1,0 - 21,0	0,5	25	33,7	112,2	15°	∅ 24,7x1,693 ± 45°/5°



Typ	Bezeichnung	Innenprofil	Spannbereich	Steigung	Verfügbar.	Preisgruppe/Price Group	PG 305
						Artikelnr.	Preis/St.
Type	Description	Ins. Shape	Clamp. Range	Increment	Availability	Part Number	Price/pc.
			mm	mm		A001.	€
349E	W20 80-92744	○	1,0 - 16,0	0,5	<input type="checkbox"/>	0349.7010 - .7160	a.A./POA
349E	W20 80-93286	○	1,0 - 20,0	1,0	<input type="checkbox"/>	0349.7010 - .7200	a.A./POA
364E	W25 80-92872	○	1,0 - 21,0	0,5	<input type="checkbox"/>	0364.7010 - .7025	a.A./POA

Bestellbeispiel:

Vorbau-Zugspannzange 364E ∅ 16 mm
▷ Artikelnr. **A001.0364.7160**

Ordering Example:

Extended Nose Draw-In Collet 364E ∅ 16 mm
▷ Part No. **A001.0364.7160**

Hydromat-Spannzangen für Pfiffner Rundtaktmaschinen

Hydromat Collets for Pfiffner Rotary Transfer Machines

Technische Daten

Technical Data

Typ	Spannbereich	Steigung	d	D	L	α	G _A
Type	Clamp. Range	Increment					
	mm	mm	mm	mm	mm		
HW20	3,0 - 20,0	0,5	20	26,3	96,5	15°	∅ 19,7x1,693 ± 45°/5°
HW25	3,0 - 25,0	0,5	25	33,7	97,6	15°	∅ 24,7x1,693 ± 45°/5°
HW25v	3,0 - 25,0	0,5	25	34	97,6	15°	∅ 24,7x1,693 ± 45°/5°
HB32	3,0 - 32,0	0,5	32	40	106	15°	∅ 29,7x1,693 ± 45°/5°
HB32/45	3,0 - 45,0	0,5	32	53	122	15°	∅ 29,7x1,693 ± 45°/5°
HB45	3,0 - 45,0	0,5	45	53	115	15°	M42x1,5



Typ	Bezeichnung	Innenprofil	Spannbereich	Steigung	Verfügbar.	Preisgruppe/Price Group	PG 310
						Artikelnr.	Preis/St.
Type	Description	Ins. Shape	Clamp. Range	Increment	Availability	Part Number	Price/pc.
			mm	mm		A003.	€
HW20	80-2030	○	3,0 - 20,0	0,5	<input type="checkbox"/>	HW20.0030 - .0200	a.A./POA
HW25	80-93174	○	3,0 - 25,0	0,5	<input type="checkbox"/>	HW25.0030 - .0250	a.A./POA
HW25v	80-233 (verstärkt/ reinforced)	○	3,0 - 25,0	0,5	<input type="checkbox"/>	HV25.0030 - .0250	a.A./POA
HB32	72-2030	○	3,0 - 32,0	0,5	<input type="checkbox"/>	HB32.0030 - .0320	a.A./POA
HB32/45	72-2033	○	3,0 - 45,0	0,5	<input type="checkbox"/>	3245.0030 - .0450	a.A./POA
HB45	72-2036	○	3,0 - 45,0	0,5	<input type="checkbox"/>	HB45.0030 - .0450	a.A./POA

Bestellbeispiel:

Hydromat-Spannzange HB32 ∅ 18,0 mm
▷ Artikelnr. **A003.HB32.0180**

Ordering Example:

Hydromat Collet HB32 ∅ 18.0 mm
▷ Part No. **A003.HB32.0180**



Notfallzangen (Kopfspannzangen)

Zur Selbsthilfe bei speziellen Durchmessern oder Formen, wenn Standardspannzangen nicht geeignet sind. Schaft gehärtet, Kopf weich (ca. 45 HRC). (kurze) Standardausführung mit Stiften in den Schlitzen. Vergrößerte Ausführung zum Spannen kurzer, größerer Werkstücke. Nur für kurzzeitigen Einsatz geeignet.



Emergency Collets (Head Collets)

For self-help, if an unusual diameter or shape is needed and standard collets cannot be used. Hardened shank and soft face (ca. 45 HRC). (Short) Standard Collet with pins in the face. Enlarged size for clamping of short, bigger workpieces. For temporary use only.



Kopfspannzangen

Head Collets

		Preisgruppe/Price Group								PG 315
Größe	Abmessung	Verfügbar.	349E (W20)		358E (B23)		359E (K23)		363E (B25)	
			Artikelnr.	Preis/St.	Artikelnr.	Preis/St.	Artikelnr.	Preis/St.	Artikelnr.	Preis/St.
Size	Dimension	Availability	Part Number	Price/pc.	Part Number	Price/pc.	Part Number	Price/pc.	Part Number	Price/pc.
	mm		A003.	€	A003.	€	A003.	€	A003.	€
0.0	Standard	<input type="checkbox"/>	0349.9000		0358.9000		0359.9000		0363.9000	
1.1	Ø 40 x 25	<input type="checkbox"/>	0349.9011		0358.9011		0359.9011		0363.9011	
1.2	Ø 40 x 50	<input type="checkbox"/>	0349.9012		0358.9012		0359.9012		0363.9012	
2.1	Ø 50 x 25	<input type="checkbox"/>	0349.9021	a.A./POA	0358.9021	a.A./POA	0359.9021	a.A./POA	0363.9021	a.A./POA
2.2	Ø 50 x 50	<input type="checkbox"/>	0349.9022		0358.9022		0359.9022		0363.9022	
3.1	Ø 75 x 25	<input type="checkbox"/>	0349.9031		0358.9031		0359.9031		0363.9031	
3.2	Ø 75 x 50	<input type="checkbox"/>	0349.9032		0358.9032		0359.9032		0363.9032	

		Preisgruppe/Price Group								PG 315
Größe	Abmessung	Verfügbar.	364E (W25)		366E		385E (5C)		386E (K32)	
			Artikelnr.	Preis/St.	Artikelnr.	Preis/St.	Artikelnr.	Preis/St.	Artikelnr.	Preis/St.
Size	Dimension	Availability	Part Number	Price/pc.	Part Number	Price/pc.	Part Number	Price/pc.	Part Number	Price/pc.
	mm		A003.	€	A003.	€	A003.	€	A003.	€
0.0	Standard	<input type="checkbox"/>	0364.9000		0366.9000		0385.9000		0386.9000	
2.1	Ø 50 x 25	<input type="checkbox"/>	0364.9021		0366.9021		0385.9021		0386.9021	
2.2	Ø 50 x 50	<input type="checkbox"/>	0364.9022		0366.9022		0385.9022		0386.9022	
3.1	Ø 75 x 25	<input type="checkbox"/>	0364.9031	a.A./POA	0366.9031	a.A./POA	0385.9031	a.A./POA	0386.9031	a.A./POA
3.2	Ø 75 x 50	<input type="checkbox"/>	0364.9032		0366.9032		0385.9032		0386.9032	
4.1	Ø 100 x 25	<input type="checkbox"/>	0364.9041		0366.9041		0385.9041		0386.9041	
4.2	Ø 100 x 50	<input type="checkbox"/>	0364.9042		0366.9042		0385.9042		0386.9042	

Bestellbeispiel:
Kopfspannzange 385E 2.1 Ø 50 x 25 mm
▷ Artikelnr. **A003.0349.9021**

Ordering Example:
Head Collet 385E 2.1 Ø 50 x 25 mm
▷ Part No. **A003.0349.9021**

Technische Info OZ- und ER-Spannzangen (Reihe 400)

Technical Info OZ and ER Collets (Series 400)

Rundlaufgenauigkeit nach DIN ISO 10897
(OZ-Spannzangen) und DIN ISO 15488
(ER-Spannzangen)

Run-out Accuracy acc. to DIN ISO 10897
(OZ Collets) und DIN ISO 15488 (ER Collets)

Ø d	l	Standard DIN Klasse2	erhöhte Genauigkeit DIN Klasse 1	Ultra-Präz. (nur ER)
		Standard DIN Cl. 2	High Acc. DIN Cl. 1	Ultra Prec. (ER only)
mm	mm	mm	mm	mm
1,0 - 1,6	6	0,015	0,010	0,005
1,6 - 3,0	10			
3,0 - 7,0	16			
7,0 - 10,0	25			
10,0 - 18,0	40	0,020	0,015	0,010
18,0 - 26,0	50			
26,0 - 34,0	60	0,025	0,020	

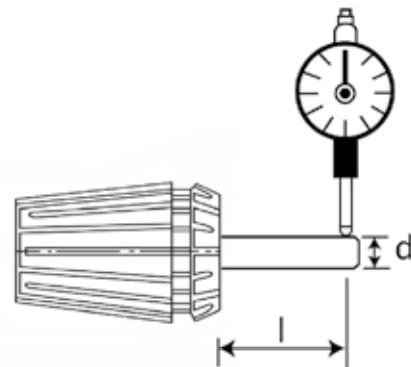

Spanntoleranzen nach
DIN ISO 10897 (OZ-Spannzangen) und
DIN ISO 15488 (ER-Spannzangen)

Clamping Tolerances acc. to
DIN ISO 10897 (OZ Collets) and
DIN ISO 15488 (ER Collets)

OZ-Spannzangen		ER-Spannzangen Form B				
Form A	Form B	ER8	ER11	alle anderen ER ≤ 2,5 mm und Bohr-Ø 3,5 / 4,5 mm	alle anderen ER ≥ 3,0 mm (nur volle Durchmesser)	ER50 ≤ 11,0 mm ≥ 12,0 mm
OZ Collets		ER Collets Type B				
Type A	Type B	ER8	ER11	all other ER ≤ 2,5 mm and bore Ø 3,5 / 4,5 mm	all other ER ≥ 3,0 mm (full diameter only)	ER50 ≤ 11,0 mm ≥ 12,0 mm
- *	- 0,5 mm	- 0,5 mm	- 0,5 mm	- 0,5 mm	- 1,0 mm	- 1,0 mm - 2,0 mm

* nur der Nenndurchmesser kann gespannt werden.

* Only the nominal size can be clamped.



OZ-Spannzangen DIN ISO 10897, einfach und doppelt geschlitzt (Reihe 400)

Zum Spannen von Werkzeugen mit zylindrischem Schaft in Spannfuttern OZ (nach DIN ISO 10897 A oder B, ehem. DIN 6388 A oder B).

Federstahl, gehärtet und geschliffen. Einfach (Form A) oder doppelt geschlitzt (Form B). Zum Spannen bis max. 0,5 mm unter Nenndurchmesser.

OZ Collets DIN ISO 10897, single and double slotted (Series 400)

For clamping of tools with cylindrical shaft in OZ collet chucks (acc. to DIN ISO 10897 A or B, formerly DIN 6388 A or B).

Spring steel, hardened and ground. Single (Type A) or double slotted (Type B). For clamping up to max. 0,5 mm under nominal size.

OZ-Spannzangen, Form A, einfach geschlitzt in metrischen Abmessungen (400 E / 401 E / 404 E 4-fach geschlitzt)

OZ Collets, Type A, single slotted in metric sizes (400 E / 401 E / 404 E with 4 slots)

Typ Type	Bezeichnung Description	L mm	D mm	Spannbereich Clamp. Range mm	Steigung Increment mm	Verfügbark. Availability	Preisgruppe/Price Group	
							Artikelnr. Part Number	Preis/St. Price/pc.
							A004.	PG 400 €
OZ6	400E	21,0	11,5	1,0 - 2,0	1,0*	■	0400.0010 - .0060	18,50
				3,0 - 6,0			0400.0010 - .0060	17,75
OZ8	401E	26,0	14,5	1,0 - 2,0	1,0*	■	0401.0010 - .0080	18,50
				3,0 - 8,0			0401.0010 - .0080	17,75
OZ10	404E	30,0	17,2	1,0 - 2,0	1,0*	■	0404.0010 - .0100	18,50
				3,0 - 10,0			0404.0010 - .0100	17,75
OZ12	407E	34,0	19,9	1,0 - 2,0	1,0*	■	0407.0010 - .0120	19,00
				3,0 - 12,0			0407.0010 - .0120	18,25
OZ10	410E	40,0	25,5	2,0 - 16,0	0,5	□	0410.0020 - .0160	13,00
OZ25	444E	52,0	35,1	2,0 - 25,0	0,5	□	0444.0020 - .0250	14,50
OZ32	450E	60,0	43,7	4,0 - 32,0	1,0	□	0450.0040 - .0320	21,00

* Preis und Lieferzeit für 0,5 mm Steigung auf Anfrage!

* Price and delivery time for 0.5 mm increment on request!

Bestellbeispiel:

Spannzange OZ12 / 407 E Ø 7,0 mm

▷ Artikelnr. A004.0407.0070

Ordering Example:

Collet OZ12 / 407 E Ø 7,0 mm

▷ Part No. A004.0407.0070

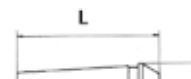

OZ-Spannzangen, Form A, einfach geschlitzt in Zoll-Abmessung (400E/401E/404E 4-fach geschlitzt)

OZ Collets, Type A, single slotted in imperial size (400 E / 401 E / 404 E with 4 slots)

Typ Type	Bezeichnung Description	L mm	D mm	Spannbereich Clamp. Range inch	Verfügbark. Availability	Preisgruppe/Price Group	
						Artikelnr. Part Number	Preis/St. Price/pc.
						B004.	PG 400 €
OZ6	400E	21,0	11,5	1/8"•1/4"	■	0400.0216 - .0416	17,75
OZ8	401E	26,0	14,5	1/8"•1/4"	■	0401.0216 - .0416	17,75
OZ10	404E	30,0	17,2	1/8"	■	0404.0416	17,75
OZ12	407E	34,0	19,9	1/8"•3/16"•1/4"•3/8"•1/2"	■	0407.0216 - .0816	18,25

Bestellbeispiel: Spannzange OZ12 / 407 E Ø 1/4" (=4/16")

▷ Artikelnr. B004.0407.0416

Ordering Example: Collet OZ12 / 407 E Ø 1/4" (=4/16")

▷ Part No. B004.0407.0416



OZ-Spannzangen, Form B, doppelt geschlitzt in metrischen Abmessungen

OZ Collets, Type B, double slotted in metric sizes

						Preisgruppe/Price Group		PG 400
Typ	Bezeichnung	L	D	Spannbereich	Steigung	Verfügbark.	Artikelnr.	Preis/St.
Type	Description			Clamp. Range	Increment	Availability	Part Number	Price/pc.
		mm	mm	mm	mm		A004.	€
OZ16	415E	40,0	25,5	2,0 - 16,0	1,0*	■	0415.0020 - .0160	10,75
OZ20	4541E	45,0	29,8	3,0 - 20,0	1,0	■	4541.0030 - .0200	20,50
OZ25	462E	52,0	35,1	2,0 - 25,0	1,0*	■	0462.0020 - .0250	11,50
OZ32	467E	60,0	43,7	4,0 - 32,0	1,0	■	0467.0040 - .0320	20,00
OZ40	468E	68,0	52,2	12,0 - 40,0	1,0	□	0468.0120 - .0400	a.A./POA

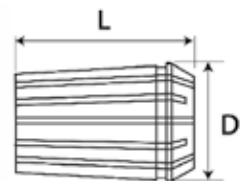

*Preis und Lieferzeit für 0,5 mm Steigung auf Anfrage!

* Price and delivery time for 0.5 mm increment on request!

Bestellbeispiel:

Spannzange OZ32 / 467 E Ø 7,0 mm

▷ Artikelnr. **A004.0467.0070**

Ordering Example:

OZ Collet OZ32 /467 E Ø 7.0 mm

▷ Part No. **A004.0467.0070**

Auf Anfrage lieferbar:

OZ Spannzangen Form B als Präzisions- (Kl. 1) oder Ultra-Präzisionsausführung (5µ)

Available on request:

OZ Collets Type B as Precision (Cl. 1) or Ultra Precision (5µ) Type

OZ-Spannzangen Sätze DIN ISO 10897 B in der Holzleiste

OZ Collets Sets DIN ISO 10897 B in Wooden Tray

						Preisgruppe/Price Group		PG 400
Typ	Bezeichnung	Zahl Zangen	Spannbereich	Steigung	Verfügbark.	Artikelnr.	Preis/St.	
Type	Description	No. Collets	Clamp. Range	Increment	Availability	Part Number	Price/pc.	
			mm	mm		A004.	€	
OZ16	415E	15	2,0 - 16,0	1,0	■	0415.0002	161,25	
OZ25	462E	24	2,0 - 25,0	1,0	■	0462.0002	275,00	
OZ32	467E	29	4,0 - 32,0	1,0	■	0467.0002	562,00	



Bestellbeispiel:

Spannzangensatz OZ25 /462 E in der Holzleiste

▷ Artikelnr. **A004.0462.0002**

Ordering Example:

OZ Collet Set OZ25 /462 E in wooden tray

▷ Part No. **A004.0462.0002**

OZ-Spannzangensätze DIN ISO 10897 B sind auf Wunsch auch im Alukoffer oder in der Holzkiste lieferbar!



OZ Collets sets DIN ISO 10897 B are available in aluminum case or wooden box on request!

ER-Spannzangen DIN ISO 15488 B, doppelt geschlitzt (Reihe 400)

Zum Spannen von Werkzeugen mit zylindrischem Schaft in Spannfuttern ER (nach DIN ISO 15488 B), ehem. DIN 6499 B. Federstahl, gehärtet und geschliffen. Doppelt geschlitzt (Form B). Zum Spannen bis max. 0,5 oder 1 mm (ER 50 2 mm) unter Nenndurchmesser.

ER Collets DIN ISO 15488 B, doubleslotted (Series 400)

For clamping of tools with cylindrical shank in ER collet chucks (acc. to DIN ISO 15488 B), formerly DIN 6499 B. Spring steel, hardened and ground. Double slotted (Type B). For clamping up to max. 0,5 or 1 mm (ER 50 2 mm) under nominal size.

ER-Spannzangen Standard (DIN/ISO KI.2 - 15-20 µm)

ER Collets Standard (DIN/ISO Cl.2 - 15-20 µm)

Typ Type	Bezeichnung Description	L mm	D mm	Spannbereich Clamp. Range mm	Steigung Increment mm	Verfügbar. Availability	Preisgruppe/Price Group	PG 405
							Artikelnr. Part Number	Preis/St. Price/pc.
							A004.	€
ER8	4004E	13,5	8,5	1,0 - 2,5	0,5	■	4004.0010 - .0025	11,50
				3,0 - 5,0			4004.0030 - .0050	10,50
ER11	4008E	18,0	11,5	1,0 - 2,5	0,5	■	4008.0010 - .0025	11,50
				3,0 - 7,0			4008.0030 - .0070	10,50
ER16	426E	27,5	17,0	1,0 - 2,5	0,5	■	0426.0010 - .0025	11,25
				3,0 - 10,0			0426.0030 - .0100	10,50
ER20	428E	31,5	21,0	1,0 - 2,5	0,5	■	0428.0010 - .0025	12,75
				3,0 - 13,0			0428.0030 - .0130	10,75
ER25	430E	34,0	26,0	1,0 - 2,5	0,5	■	0430.0010 - .0025	12,75
				3,0-5,0/6,0-16,0			0430.0030 - .0160	10,75
ER32	470E	40,0	33,0	1,0 - 2,5	0,5	□	0470.0010 - .0025	13,75
				3,0 - 20,0			0470.0030 - .0200	11,25
ER40	472E	46,0	41,0	2,0	1,0	□	0472.0020	22,50
				3,0 - 26,0			0472.0030 - .0260	14,00
ER50	477E	60,0	52,0	6,0 - 11,0	1,0	■	0477.0060 - .0110	53,75
				12,0 - 34,0			0477.0120 - .0340	36,50



Bestellbeispiel:
Spannzange ER 16 / 426 E Ø 7,5 mm
▷ Artikelnr. A004.0426.0075

Ordering Example:
Collet ER 16 / 426 E Ø 7.5 mm
▷ Part No. A004.0426.0075

ER-Präzisions-Spannzangen (DIN/ISO KI.1 - 10-15 µm)

ER Precision Collets (DIN/ISO Cl.1 - 10-15 µm)

Typ Type	Bezeichnung Description	L mm	D mm	Spannbereich Clamp. Range mm	Steigung Increment mm	Verfügbar. Availability	Preisgruppe/Price Group	PG 405
							Artikelnr. Part Number	Preis/St. Price/pc.
							A004.	€
ER8	4004E-HP	13,5	8,5	1,0 - 2,5	0,5	■	4004.1010 - .1025	16,50
				3,0 - 5,0			4004.1030 - .1050	15,25
ER11	4008E-HP	18,0	11,5	1,0 - 2,5	0,5	■	4008.1010 - .1025	16,50
				3,0 - 7,0			4008.1030 - .1070	15,25
ER16	426E-HP	27,5	17,0	1,0 - 2,5	0,5	■	0426.1010 - .1025	15,75
				3,0 - 10,0			0426.1030 - .1100	15,25
ER20	428E-HP	31,5	21,0	1,0 - 2,5	0,5	■	0428.1010 - .1025	17,50
				3,0-5,0/6,0-13,0			0428.1030 - .1130	17,00
ER25	430E-HP	34,0	26,0	1,0 - 2,5	0,5	■	0430.1010 - .1025	17,50
				3,0-5,0/6,0-16,0			0430.1030 - .1160	17,00
ER32	470E-HP	40,0	33,0	1,0 - 2,5	0,5	□	0470.1010 - .1025	21,25
				3,0-5,0/6,0-20,0			0470.1030 - .1200	18,25
ER40	472E-HP	46,0	41,0	2,0	0,5	□	0472.1020	27,50
				3,0-5,0/6,0-26,0			0472.1030 - .1260	22,50
ER50	477E-HP	60,0	52,0	6,0 - 11,0	1,0	□	0477.1060 - .1110	a.A./POA
				12,0 - 34,0			0477.1120 - .1340	45,00



Bestellbeispiel:
Präzisionsspannzange ER 40-HP / 472 E-HP
▷ Artikelnr. A004.0472.1100

Ordering Example:
Precision Collet ER 40-HP / 472 E-HP Ø 10.0 mm
▷ Part No. A004.0472.1100

ER-Ultra-Präzisionsspannzangen (5 µm)

ER Ultra Precision Collets (5 µm)

Typ	Bezeichnung	L	D	Spannbereich	Steigung	Verfügbark.	Preisgruppe/Price Group	
							Artikelnr.	Preis/St.
Type	Description	mm	mm	Clamp. Range	Increment	Availability	Part Number	Price/pc.
							A004.	€
ER8	4004E-UP	13,5	8,5	1,0 - 2,5	0,5	■	4004.6010 - .6025	25,50
				3,0 - 5,0			4004.6030 - .6050	20,50
ER11	4008E-UP	18,0	11,5	1,0 - 2,5	0,5	■	4008.6010 - .6025	25,50
				3,0 - 7,0			4008.6030 - .6070	20,50
ER16	426E-UP	27,5	17,0	1,0 - 2,5	0,5	■	0426.6010 - .6025	23,25
				3,0 - 10,0			0426.6030 - .6100	17,25
ER20	428E-UP	31,5	21,0	1,0 - 2,5	0,5	■	0428.6010 - .6025	26,00
				3,0-5,0/6,0-13,0			0428.6030 - .6130	19,00
ER25	430E-UP	34,0	26,0	1,0 - 2,5	0,5	■	0430.6010 - .6025	26,00
				3,0-5,0/6,0-16,0			0430.6030 - .6160	19,00
ER32	470E-UP	40,0	33,0	1,0 - 2,5	0,5	□	0470.6010 - .6025	27,00
				3,0-5,0/6,0-20,0		0470.6030 - .6045	21,25	
ER40	472E-UP	46,0	41,0	2,0 - 2,5	0,5	□	0472.6020 - .6025	30,00
				3,0-5,0/6,0-26,0		0472.6030 - .6260	25,00	
ER50	477E-UP	60,0	52,0	12,0 - 34,0	2,0	□	0477.6120 - .6340	52,50

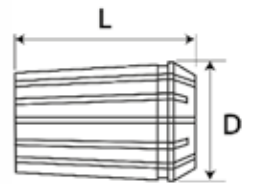

Bestellbeispiel:

Ultra-Präzisionsspannzange ER 16-UP / 426 E-UP Ø 4,0 mm
 ▷ Artikelnr. **A004.0426.6040**

Ordering Example:

Ultra Precision collet ER 16-UP / 426 E Ø 4.0 mm
 ▷ Part No. **A004.0426.6040**

ER-Ultra-Präzisionsspannzangen (2 µm)

ER Ultra Precision Collets (2 µm)

Typ	Bezeichnung	L	D	Spannbereich	Steigung	Verfügbark.	Preisgruppe/Price Group	
							Artikelnr.	Preis/St.
Type	Description	mm	mm	Clamp. Range	Increment	Availability	Part Number	Price/pc.
							A004.	€
ER25	430E-MP	34,0	26,0	3,0 - 16,0	1,0	□	0430.8030 - .8160	37,90
ER32	470E-MP	40,0	33,0	3,0 - 20,0	1,0	□	0470.8030 - .8200	37,90
ER40	472E-MP	46,0	41,0	3,0 - 26,0	1,0	□	0472.8030 - .8260	47,60



Bestellbeispiel:

Mega-Präzisionsspannzange ER 25-MP / 430 E-MP Ø 6,0 mm
 ▷ Artikelnr. **A004.0426.7060**

Ordering Example:

Mega Precision collet ER 25-MP / 430E-MP Ø 6.0 mm
 ▷ Part No. **A004.0426.7060**

ER-Spannzangen mit übermäßigem Durchmesser

ER Collets with oversize diameter

Zur Verwendung in sehr engen Bereichen bei der Zerspanung bzw. zur Vermeidung von Interferenzen. Einsetzbar in normalen ER-Haltern. Verkürzte Länge, dadurch kürzere Einspannlänge des Werkzeugs. Dünnwandiger, dadurch reduzierte Spannkraft und Lebensdauer. Nur das Nennmaß kann gespannt werden.

For use in tight areas during cutting and to avoid interferences. Useable with standard ER holders. Shortened length, thus shorter clamping length of the tool. Thinwalled, thereby reduced clamping force and endurance. Only the nominal size can be clamped.

Typ	Bezeichnung	L*	D	Spannbereich	Steigung	Verfügbark.	Preisgruppe/Price Group	
							Artikelnr.	Preis/St.
Type	Description	mm	mm	Clamp. Range	Increment	Availability	Part Number	Price/pc.
							A004.	€
ER11	4008E	< DIN	11,5	7,5 - 8,0	0,5	■	4008.0075 - .0080	33,75
ER16	426E		17,0	10,5-12,0	0,5	■	0426.0105 - .0120	33,75
ER20	428E		21,0	14,0 - 16,0	0,5	■	0428.0140 - .0160	35,00
ER25	430E		26,0	17,0 - 20,0	0,5	■	0430.0170 - .0200	35,00
ER32	470E		33,0	21,0 - 25,0	1,0	■	0470.0210 - .0250	36,25
ER40	472E		41,0	27,0 - 32,0	1,0	■	0472.0270 - .0320	40,00



Präzision (15-20 µm) und Ultra-Präzision (5 µm) auf Anfrage lieferbar!

Precision (15-20 µm) and Ultra Precision (5 µm) available on request!

* unterschiedlich für jeden Durchmesser

* differing for every diameter

Bestellbeispiel:

ER-Präzisionsspannzange ER16 / 426 E Ø 12,0 mm
 ▷ Artikelnr. **A004.0426.1120**

Ordering Example:

Precision Collet ER16 / 426E Ø 12.0 mm
 ▷ Part No. **A004.0426.1120**

■ Lagerstandard* (s. S. 35)
 Stock item* (see p 35)

□ Teilweise im Lager
 Partially in stock

□ Auf Anfrage lieferbar
 Available on request

a.A. - Auf Anfrage
 POA - Price on Application



ER-Spannzangensätze DIN ISO 15488 B Standard (15-20 µm), Präzision (10-15 µm), Ultra Präzision (5 µm)

ER Collets Sets DIN ISO 15488 B Standard (15-20 µm), Präzision (10-15 µm), Ultra Präzision (5µm)

Satzzusammenstellung Set Configuration				Holzleiste	Alukoffer	Holzleiste
				Zahl Zangen	Zahl Zangen	Zahl Zangen
Typ	Bezeichnung	Spannber.	Steigung	Wooden Tray	Alu Case	Wooden Box
Type	Description	Clamp. Range	Increment	No. Collets	No. Collets	No. Collets
		mm	mm			
ER8	4004E	1,0 - 5,0	0,5	9	-	-
ER11	4008E	1,0 - 7,0	0,5	13	-	-
ER16	426E	1,0 - 10,0	1,0	10	10	10
ER20	428E	2,0 - 13,0	1,0	12	12	12
ER25	430E	2,0 - 16,0	1,0	15	15	15
ER32	470E	3,0 - 20,0	1,0	18	18	18
ER40	472E	4,0 - 26,0	1,0	23	23	23
ER50	477E	6,0 - 11,0 12,0 - 34,0*	1,0 2,0	-	18 / 12(HP/UP)*	-

* Satz ER50-HP / -UP: 12 Spannzangen 12,0-34,0 mm
Set ER50-HP / -UP: 12 collets 12.0-34.0 mm

ER-Spannzangensätze in der Holzleiste

ER Collet Sets in Wooden Tray

Holzleiste / Wooden Tray			Preisgruppe/Price Group PG 405					
			ER Standard (15-20µm)		ER-HP (10-15µm)		ER-UP (5µm)	
Typ	Bezeichnung	Verfügbar.	Artikelnr.	Preis/St.	Artikelnr.	Preis/St.	Artikelnr.	Preis/St.
Type	Description	Availability	Part Number	Price/pc.	Part Number	Price/pc.	Part Number	Price/pc.
			A004.	€	A004.	€	A004.	€
ER8	4004E	■	4004.0002	105,00	4004.1002	150,00	4004.6002	210,00
ER11	4008E	■	4008.0002	145,00	4008.1002	207,50	4008.6002	282,50
ER16	426E	■	0426.0002	110,75	0426.1002	155,00	0426.6002	187,50
ER20	428E	■	0428.0002	136,75	0428.1002	210,00	0428.6002	235,00
ER25	430E	■	0430.0002	168,75	0430.1002	255,00	0430.6002	295,00
ER32	470E	■	0470.0002	210,00	0470.1002	330,00	0470.6002	385,00
ER40	472E	■	0472.0002	331,50	0472.1002	525,00	0472.6002	580,00



ER-Spannzangensätze im Alukoffer

ER Collet Sets in Aluminium Case

Alukoffer / Alu Case			Preisgruppe/Price Group PG 405					
			ER Standard (15-20µm)		ER-HP (10-15µm)		ER-UP (5µm)	
Typ	Bezeichnung	Verfügbar.	Artikelnr.	Preis/St.	Artikelnr.	Preis/St.	Artikelnr.	Preis/St.
Type	Description	Availability	Part Number	Price/pc.	Part Number	Price/pc.	Part Number	Price/pc.
			A004.	€	A004.	€	A004.	€
ER16	426E	■	0426.0001	125,00	0426.1001	175,00	0426.6001	205,00
ER20	428E	■	0428.0001	150,00	0428.1001	225,00	0428.6001	252,50
ER25	430E	■	0430.0001	180,00	0430.1001	265,00	0430.6001	310,00
ER32	470E	■	0470.0001	225,00	0470.1001	345,00	0470.6001	395,00
ER40	472E	■	0472.0001	345,00	0472.1001	547,50	0472.6001	597,50
ER50	477E	■	0477.0001	669,00	0477.1001	582,50	0477.6001	672,50



ER-Spannzangensätze in der Holzleiste

ER Collet Sets in Wooden Box

Holzleiste / Wooden Box			Preisgruppe/Price Group PG 405					
			ER Standard (15-20µm)		ER -HP (10-15µm)		ER-UP (5µm)	
Typ	Bezeichnung	Verfügbar.	Artikelnr.	Preis/St.	Artikelnr.	Preis/St.	Artikelnr.	Preis/St.
Type	Description	Availability	Part Number	Price/pc.	Part Number	Price/pc.	Part Number	Price/pc.
			A004.	€	A004.	€	A004.	€
ER16	426E	■	0426.0003	135,00	0426.1003	185,00	0426.6003	215,00
ER20	428E	■	0428.0003	160,00	0428.1003	235,00	0428.6003	262,50
ER25	430E	■	0430.0003	190,00	0430.1003	275,00	0430.6003	320,00
ER32	470E	■	0470.0003	240,00	0470.1003	360,00	0470.6003	410,00
ER40	472E	■	0472.0003	360,00	0472.1003	562,50	0472.6003	612,50



Bestellbeispiel:

Ultra-Präzisionsspannzangensatz ER16-UP / 426 E-UP in der Holzleiste
▷ Art. Nr. A004.0426.6002

Ordering Example:

Ultra Precision Collet Set ER16-UP / 426 E-UP in wooden tray
▷ Part No. A004.0426.6002



Abgedichtete ER-Spannzangen ähnlich DIN ISO 15488 A, einfach geschlitzt

Max. 70 bar. Nur das Nennmaß kann gespannt werden.

Sealed ER Collets similar to DIN ISO 15488 A, single slotted

Max. 1015 psi. Only the nominal size can be clamped.

Typ	Bezeichnung	Spannbereich	Steigung	L	D	Verfügbar.	Preisgruppe/Price Group	
							Artikelnr.	Preis/St.
Type	Description	Clamp. Range	Increment	mm	mm	Availability	Part Number	Price/pc.
		mm	mm	mm	mm		A004.	€
ER11	4012E	3,0 - 7,0	0,5	18,0	11,5	■	4012.3030 - .3070	27,90
ER16	425E	3,0 - 10,0	1,0	27,5	17,0	■	0425.3030 - .3100	27,90
ER20	427E	3,0 - 13,0	1,0	31,5	21,0	■	0427.3030 - .3130	30,00
ER25	429E	3,0 - 16,0	1,0	34,0	26,0	■	0429.3030 - .3160	30,50
ER32	469E	3,0 - 20,0	1,0	40,0	33,0	■	0469.3030 - .3200	31,00
ER40	471E	4,0 - 26,0	1,0	46,0	41,0	■	0471.3040 - .3260	36,25

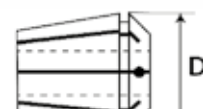

Bestellbeispiel:

Abgedichtete Spannzange ER 32 Ø 18,0 mm

▷ Artikelnr. **A004.0469.3180**

Ordering Example:

Sealed Collet ER 32 Ø 18.0 mm

▷ Part No. A004.0469.3180

Mechanisch abgedichtete ER-Spannzangen

Max. 120 bar. Nur das Nennmaß kann gespannt werden.

Mechanically sealed ER Collets

Max. 1740 psi. Only the nominal size can be clamped.

Typ	Bezeichnung	Spannbereich	Steigung	L	D	Verfügbar.	Preisgruppe/Price Group	
							Artikelnr.	Preis/St.
Type	Description	Clamp. Range	Increment	mm	mm	Availability	Part Number	Price/pc.
		mm	mm	mm	mm		A004.	€
ER16	425E-M	1,0 - 2,0	1,0	27,5	17,0	□	0425.7010 - .7020	40,00
		3,0 - 12,0				■	0425.7030 - .7120	31,60
ER20	427E-M	3,0 - 14,0	1,0	31,5	21,0	□	0427.7030 - .7140	31,60
		3,0 - 16,0				■	0429.7030 - .7180	31,60
ER25	429E-M	18,0	-	34,0	26,0	□	0429.7030 - .7180	40,00
		3,0 - 20,0				■	0469.7030 - .7220	31,60
ER32	469E-M	20,0 - 22,0	1,0	40,0	33,0	□	0469.7030 - .7220	40,00
		6,0-18,0+20+25+26,0				□	0471.7040 - .7260	40,00
ER40	471E-M	30,0	-	46,0	41,0	□	0471.7030	43,60



Bestellbeispiel:

Mechanisch abgedichtete Spannzange ER 32 Ø 18,0 mm

▷ Artikelnr. **A004.0469.7180**

Ordering Example:

Mechanically sealed collet ER 32 Ø 18.0 mm

▷ Part No. A004.0469.7180

Abgedichtete ER-Spannzangen mit Spritzdüsen

Max. 70 bar. Nur das Nennmaß kann gespannt werden.

Sealed ER Collets with Jet Holes

Max. 1015 psi. Only the nominal size can be clamped.

Typ	Bezeichnung	Spannbereich	Steigung	L	D	Verfügbar.	Preisgruppe/Price Group	
							Artikelnr.	Preis/St.
Type	Description	Clamp. Range	Increment	mm	mm	Availability	Part Number	Price/pc.
		mm	mm	mm	mm		A004.	€
ER16	425E-J	3,0 - 10,0	1,0	27,5	17,0	■	0425.5030 - .5100	45,00
ER20	427E-J	3,0 - 13,0	1,0	31,5	21,0	□	0427.5030 - .5130	46,25
ER25	429E-J	3,0 - 16,0	1,0	34,0	26,0	■	0429.5030 - .5160	48,75
ER32	469E-J	3,0 - 20,0	1,0	40,0	33,0	■	0469.5030 - .5200	53,75
ER40	471E-J	4,0 - 26,0	1,0	46,0	41,0	□	0471.5040 - .5260	61,25



Bestellbeispiel:

Abgedichtete Spannzange mit Spritzdüsen ER 32 Ø 18,0 mm

Artikelnr. **A004.0469.5180**

Ordering Example:

Sealed collet with jet holes ER 32 Ø 18.0 mm

▷ Part No. A004.0469.5180

Abgedichtete ER-Spannzangensätze DIN ISO 15488 B sind auf Wunsch auch im Satz (Holzleiste, Holzkiste oder Alukoffer) lieferbar!

Sealed ER collet sets DIN ISO 15488 B are available (in wooden tray, wooden box or aluminum case) on request!

ER-Gewindebohrzangen mit Innenvierkant, ähnlich DIN ISO 15488 A, einfach geschlitzt

Gewindebohrzangen ohne Längenausgleich. Nur das Nennmaß kann gespannt werden.

ER Tapping Collets with square drive, similar to DIN ISO 15488 A, single slotted

Tapping collets without axial length compensation. Only the nominal size can be clamped.

Typ	Bezeichnung	L	D	Schaft- \varnothing x \square	Verfügbark.	Preisgruppe/Price Group	PG 408
						Artikelnr.	Preis/St.
Type	Description			Shank \varnothing x \square	Availability	Part Number	Price/pc.
		mm	mm	mm		A004.	€
ER16	4031E	27,5	17	2,8x2,1	■	4031.2028	32,50
ER16	4031E	27,5	17	3,5x2,7 - 4x3 - 4,5x3,4 - 5,5x4,3 - 6x4,9 - 7x5,5 - 8x6,2 - 9x7 - 10x8	■	4031.2035/.2040/ .2045/.2055/.2060/ .2070/.2080/.2090/.2100	27,75
ER20	4276E	31,5	21	3,5x2,7 - 4x3 - 4,5x3,4 - 5,5x4,3 - 6x4,9 - 7x5,5 - 8x6,2 - 9x7 - 10x8 - 11x9 - 12x9	■	4276.2035/.2040/ .2045/.2055/.2060/ .2070/.2080/.2090/ .2100/.2110/.2120	30,00
ER25	4282E	34,0	26	3,5x2,7 - 4x3 - 4,5x3,4 - 5,5x4,3 - 6x4,9 - 7x5,5 - 8x6,2 - 9x7 - 10x8 - 11x9 - 12x9 - 14x11 - 16x12 - 18x14,5 - 20x16	■	4282.2035/.2040/ .2045/.2055/.2060/ .2070/.2080/.2090/.2100	30,50
ER32	4537E	40,0	33	7x5,5 - 8x6,2 - 9x7 - 10x8 - 11x9 - 12x9 - 14x11 - 16x12 - 18x14,5 - 20x16 - 22x18 - 25x20 - 28x22 - 32x24	■	4537.2040/.2045/.2055/ .2060/.2070/.2080/.2090 .2100/.2110/.2120/.2140 .2160/.2180/.21200	31,00
ER40	4716E	46,0	41	6x4,9 - 7x5,5 - 8x6,2 - 9x7 - 10x8 - 11x9 - 12x9 - 14x11 - 16x12 - 18x14,5 - 20x16 - 22x18 - 25x20 - 28x22 - 32x24	■	4716.2060/.2070/.2080/ .2090/.2100/.2110/ .2120/.2140/.2160/ .2180/.2200/.2220	33,75
ER50		46,0	41		□	5000.2080/.2090/.2100/ .2110/.2140/.2160/ .2180/.2200/.2220/ .2250/.2280/.2320	77,50

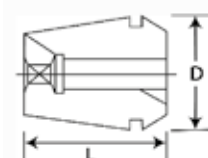

Bestellbeispiel:
Gewindebohrspannzange ER25 8 x 6,2 mm
▷ Artikelnr. **A004.4282.2080**

Ordering Example:
Tapping Collet ER25 8 x 6.2 mm
▷ Part No. **A004.4282.2080**

Abgedichtete ER-Gewindebohrzangen mit Innenvierkant, ähnlich DIN ISO 15488 A, einfach geschlitzt

Sealed ER Tapping Collets with square drive, similar to DIN ISO 15488 A, single slotted

Typ	Bezeichnung	L	D	Schaft- \varnothing x \square	Verfügbark.	Preisgruppe/Price Group	PG 408
						Artikelnr.	Preis/St.
Type	Description			Shank \varnothing x \square	Availability	Part Number	Price/pc.
		mm	mm	mm		A004.	€
ER16	4031E	27,5	17	wie in der oberen Tabelle aufgelistet / as listed in the upper table	□	4031.3xxx	a.A./POA
ER20	4276E	31,5	21		□	4276.3xxx	
ER25	4282E	34,0	26		□	4282.3xxx	
ER32	4537E	40,0	33		□	4537.3xxx	
ER40	4716E	46,0	41		□	4716.3xxx	

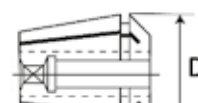

Bestellbeispiel:
Abgedichtete Gewindebohrspannzange ER32 11 x 9 mm
▷ Artikelnr. **A004.4537.3110**

Ordering Example:
Sealed Tapping Collet ER32 11 x 9 mm
▷ Part No. **A004.4537.3110**



DK-Spannzangen (System Erickson/Serie 400)

Für Futter und Spannzangenhalter System Erickson DK (Doppelkonus). Federstahl, gehärtet und geschliffen. Zum Spannen bis max. 0,5 mm unter Nenndurchmesser.

DA Collets (system Erickson/Serie 400)

For chucks and collet holders system Erickson DA (Double Angle). Spring steel, hardened and ground. For clamping up to max. 0,5 mm under nominal size.

Typ	Bezeichnung	L	D	Spannbereich	Steigung	Verfügbark.	Preisgruppe/Price Group	
							Artikelnr.	Preis/St.
Type	Description	mm	mm	Clamp. Range	Increment	Availability	Part Number	Price/pc.
							A004.	€
DK-S Supra	412E	16,3	6,8	1,00 - 2,00	0,25	■	0412.0100 - .0200	33,00
				2,25 - 3,00			0412.0225 - .0300	30,25
				3,25 - 4,00			0412.0325 - .0400	20,65
DK30	416E	25,4	9,5	1,0 - 2,5	0,5	■	0416.0010 - .0025	13,15
				3,0 - 6,5			0416.0030 - .0065	11,65
DK20	417E	30,3	13,6	1,0 - 2,5	0,5	■	0417.0010 - .0025	13,40
				3,0 - 10,0			0417.0030 - .0100	11,90
DK10	418E	36,7	19,4	1,0 - 2,5	0,5	■	0418.0010 - .0025	14,40
				3,0 - 14,5			0418.0030 - .0145	12,90
DK18	419E	41,6	26,2	1,0 - 2,5	0,5	■	0419.0010 - .0025	17,00
				3,0 - 20,0			0419.0030 - .0200	15,25
DK40	465E	51,0	36,9	6,0 - 25,0	1,0	■	0465.0060 - .0250	38,00

Bestellbeispiel:

Erickson-Spannzange DK-S Supra / 412 E Ø 3,75 mm
▷ Artikelnr. A004.0412.0375

Ordering Example:

Erickson Collet DA-S Supra / 412 E Ø 3,75 mm
▷ Part No. A004.0412.0375



Zylindrische Spannzangenhalter für DK-Spannzangen

Cylindrical Erickson Collet Chuck Holder for DA collets

Typ	DK-Spannzange	Spannbereich	L	d	l	D	Verfügbark.	Preisgruppe/Price Group	
								Artikelnr.	Preis/St.
Type	DA Collet	Clamp. Range	mm	mm	mm	mm	Availability	Part Number	Price/pc.
							A182.	€	
DK-S Supra	412E	1,00 - 4,00	100	8	32	10	■	0412.0810	81,00
DK30	416E	1,0 - 6,5	76	12	36	14	■	0416.1276	64,00
			140					0416.1214	68,00
DK20	417E	1,0 - 10,0	76	20	44	21	■	0417.2076	68,00
			140					0417.2014	72,00
DK10	418E	1,0 - 14,5	76	25	49,4	27	■	0418.2576	74,00
			140					0418.2514	82,00

Bestellbeispiel:

Erickson-Spannzangenhalter DK Supra 412 E
A004.0412.0810

Ordering Example:

Erickson Collet Chuck Holder DA Supra 412 E
A004.0412.0810



DF-Spannzangen (System Erickson/Serie 400)

TG Collets (System Erickson/Serie 400)

Typ	Bezeichnung	L	D	Spannbereich	Steigung	Verfügbark.	Preisgruppe/Price Group	
							Artikelnr.	Preis/St.
Type	Description	mm	mm	Clamp. Range	Increment	Availability	Part Number	Price/pc.
							A004.	€
DF75	420E	46,9	27,0	3,0 - 20,0	0,5	□	0420.0030 - .0200	42,50
DF10	464E	60,4	35,0	6,0 - 25,4	0,5	■	0464.0060 - .0254	47,00
DF15	466E	76,2	50,8	12,0 - 40,0	0,5	□	0466.0120 - .0400	76,50

Bestellbeispiel:

Erickson-Spannzange DF 10 464 E Ø 10,0 mm
A004.0464.0100

Ordering Example:

Erickson Collet TG10 464 E Ø 10,0 mm
A004.0464.0100





Spannzangen für Mehrspindelbohrköpfe

Collets for Multispindle Drill Heads

Spannzangen für Mehrspindelbohrköpfe (Reihe 600) mit Sechskant-Schlüsselfläche

Collets for Multispindle Drill Heads (Series 600) with Hexagon Head

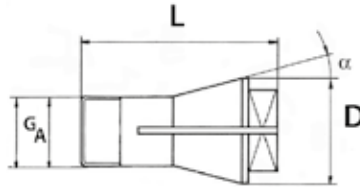

Technische Daten

Technical Data

Typ	Spannbereich	SW	Gewinde	D	d	L	α
Type	Clamp. Range	Hex Size	Thread				
	mm	mm	G _A	mm	mm	mm	
6023E	1,0 - 3,0	5,5	M5x0,6	6,5	5,0	20,0	20°
6043E	1,0 - 4,0	6,5	M6x0,7	8,5	6,0	25,5	20°
600E	1,0 - 4,0	7,0	M6x0,75	9,0	6,0	28,5	10°
601E	1,0 - 6,0	9,0	M8x0,75	11,0	8,0	33,0	10°
603E	1,0 - 6,0	9,0	M8x0,85	11,5	8,0	30,5	20°
6314E	1,0 - 8,0	11,0	M10x0,75	14,0	10,0	34,0	15°
635E	1,0 - 10,0	14,0	M12x0,75	18,0	12,0	34,0	15°

Typ*	Innenprofil	Spannbereich	Steigung	Verfügbar.	Preisgruppe/Price Group	PG 600
					Artikelnr.	Preis/St.
Type*	Ins. Shape	Clamp. Range	Increment	Availability	Part Number	Price/pc.
		mm	mm		A006.	€
6023E	○	1,0	0,5	□	6023.0010	71,50
		1,5 - 2,5			6023.0015 - .0025	53,75
		3,0			6023.0030	34,75
6043E	○	1,0	1,0	□	6043.0010	71,50
		1,5 - 2,5	0,5		6043.0015 - .0025	53,75
		3,0 - 4,0			6043.0030 - .0040	34,75
600E	○	1,0	0,5	■	0600.0010	71,50
		1,5 - 2,5			0600.0015 - .0025	53,75
		3,0 - 4,0			0600.0030 - .0040	34,75
601E	○	1,0	0,5	■	0601.0010	71,50
		1,5 - 2,5			0601.0015 - .0025	53,75
		3,0 - 6,0			0601.0030 - .0060	34,75
603E	○	1,0	0,5	■	0603.0010	71,50
		1,5 - 2,5			0603.0015 - .0025	53,75
		3,0 - 6,0			0603.0030 - .0060	34,75
6314E	○	1,0	0,5	□	6314.0010	71,50
		1,5 - 2,5		□	6314.0015 - .0025	53,75
		3,0 - 8,0		■	6314.0030 - .0080	34,75
635E	○	1,0	0,5	□	0635.0010	71,50
		1,5 - 2,5		□	0635.0015 - .0025	53,75
		3,0 - 10,0		■	0635.0030 - .0100	34,75

*602E / 632E / 634E / 636E / 6369E auf Anfrage lieferbar!

Bestellbeispiel:

Spannzange 632E Ø 3,0 mm

A006.0632.0060

*602E / 632E / 634E / 636E / 6369E available on request!

Ordering Example:

Collet 632E Ø 3.0 mm

A006.0632.0060



Impressum:

© 2018 Andreas Hauck Industrietechnik

Gedruckt in Deutschland 04/2018. Gültig bis 30.06.2019 oder bis auf Widerruf.

Alle Angaben sind unverbindlich. Technische Änderungen sind ohne vorherige Ankündigung vorbehalten.

Für Abweichungen, Irrtümer und Druckfehler kann keine Gewähr übernommen werden.

Im übrigen gelten die AGB der Andreas Hauck Industrietechnik.

Nachdruck und Vervielfältigung gleich welcher Art, auch auszugsweise, bedarf unserer vorherigen schriftlichen Zustimmung.

REVOTEC Spanntechnik ist eine eingetragene Marke der Andreas Hauck Industrietechnik.

Info zur Artikelverfügbarkeit:

* Lagerstandard: Die Verfügbarkeit "Lagerstandard" bedeutet, dass wir normalerweise diesen Artikel in den verschiedenen Durchmessern im Lager bevorraten, es bedeutet aber keine Garantie, dass der Artikel zum Zeitpunkt der Bestellung auch vorrätig ist.

Legal Notice/Disclaimer:

© 2018 Andreas Hauck Industrietechnik

Printed in Germany 04/2018. Valid until 30.06.2019 or until revoked.

All information and data is without obligation. All technical data is subject to change without prior notice.

We do not take any responsibility for discrepancies, mistakes and misprints.

The terms and conditions of the Andreas Hauck Industrietechnik apply.

Reprint and duplication of any kind, even parts thereof, are not allowed without the written consent by us.

REVOTEC Spanntechnik is a registered trademark of Andreas Hauck Industrietechnik.

Info about the product availability:

* "Stock item" means, that we usually stock this item with its various diameters, but it is no guarantee, that this item is available at the time of ordering

Wir liefern außerdem:

We additionally supply:



Zubehör
Accessories



Werkzeugaufnahmen
Tool Holders



Ausschleifservice im Haus
In-House Grinding Service



REVOTEC®
Spanntechnik

Verwaltung / Lager
Office / Warehouse:

Andreas Hauck Industrietechnik
Erwin-Bahn Müller-Str. 41
71394 Kernen / Germany
Tel. +49 7151 9940993
Fax +49 7151 9940998
Email: info@revotec-shop.de
Web: <https://revotec-shop.de>

Sitz der Firma / Rechnungsanschrift:
Registered Office / Invoice Address:

Andreas Hauck Industrietechnik
Gaildorfer Str. 29
70374 Stuttgart / Germany